

**Cooling generation systems
and
Insights on efficient production systems**

Generation systems 1/2

- Heating:
 - Boilers:
 - Fossil Fuels
 - Biomass boilers
 - Heat pumps (source/sink media):
 - Air-to-water
 - Water-to-water
 - Air-to-air
 - Water-to-air

Generation systems 2/2

- **Cooling:**
 - **Compression Chillers:**
 - **Hydronic system**
 - **Condensation in air**
 - **Condensation in water**
 - **Direct expansion**
 - **Split systems/VRV**
 - **Rooftop**
 - **Absorption chillers:**

AIR TO WATER CHILLER

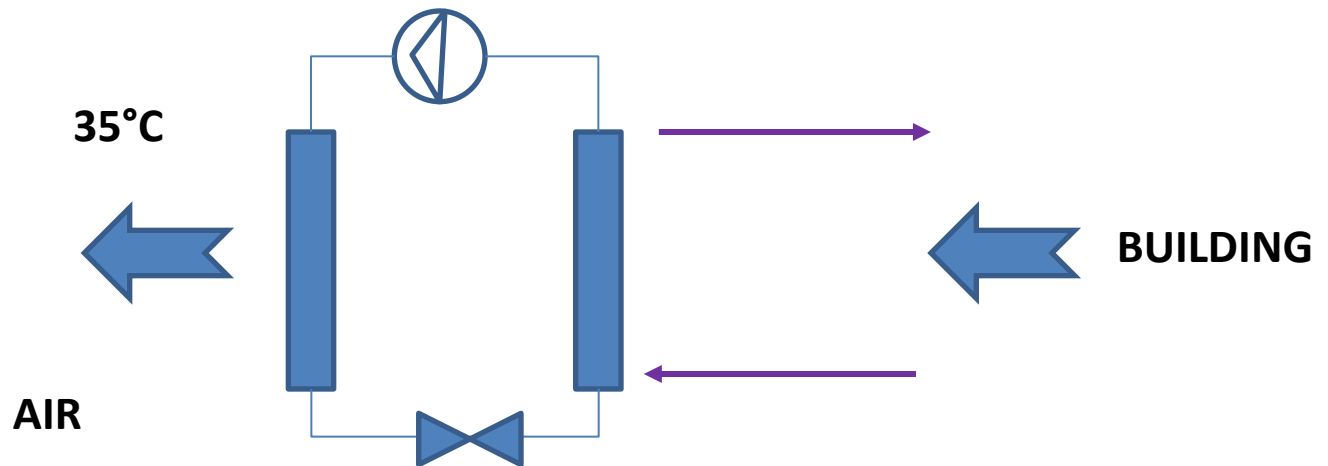

WATER TO WATER CHILLER



COOLING TOWER

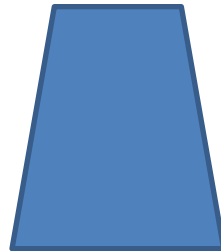

26°C

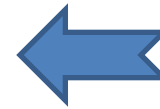
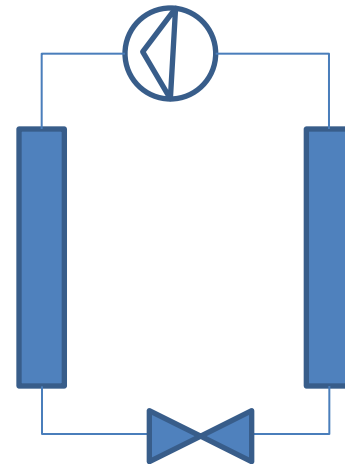
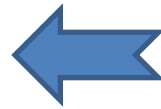

BUILDING

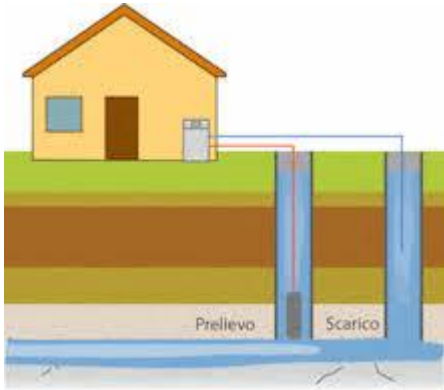

AQUIFER

15°C

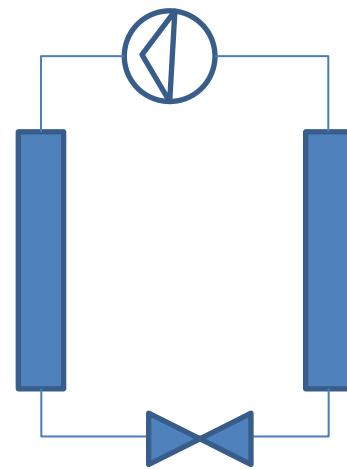
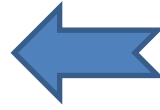

BUILDING

GROUND HEAT EXCHANGER

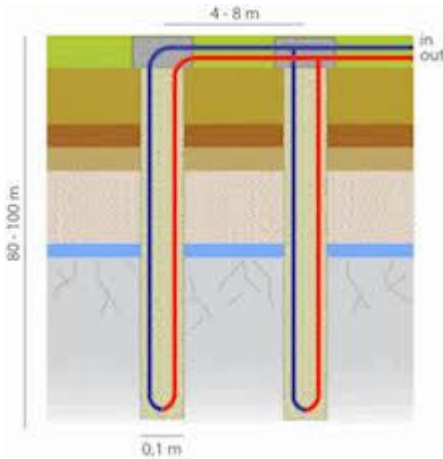

25°C

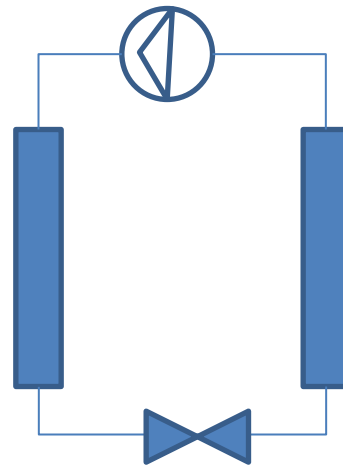
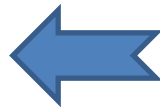

BUILDING

AIR TO WATER CHILLER

REFRIGERANT SIDE

Means to keep the water loop temperature within range:

Chiller and boiler OR Drycooler and boiler OR Heat pump chiller OR Geothermal loop

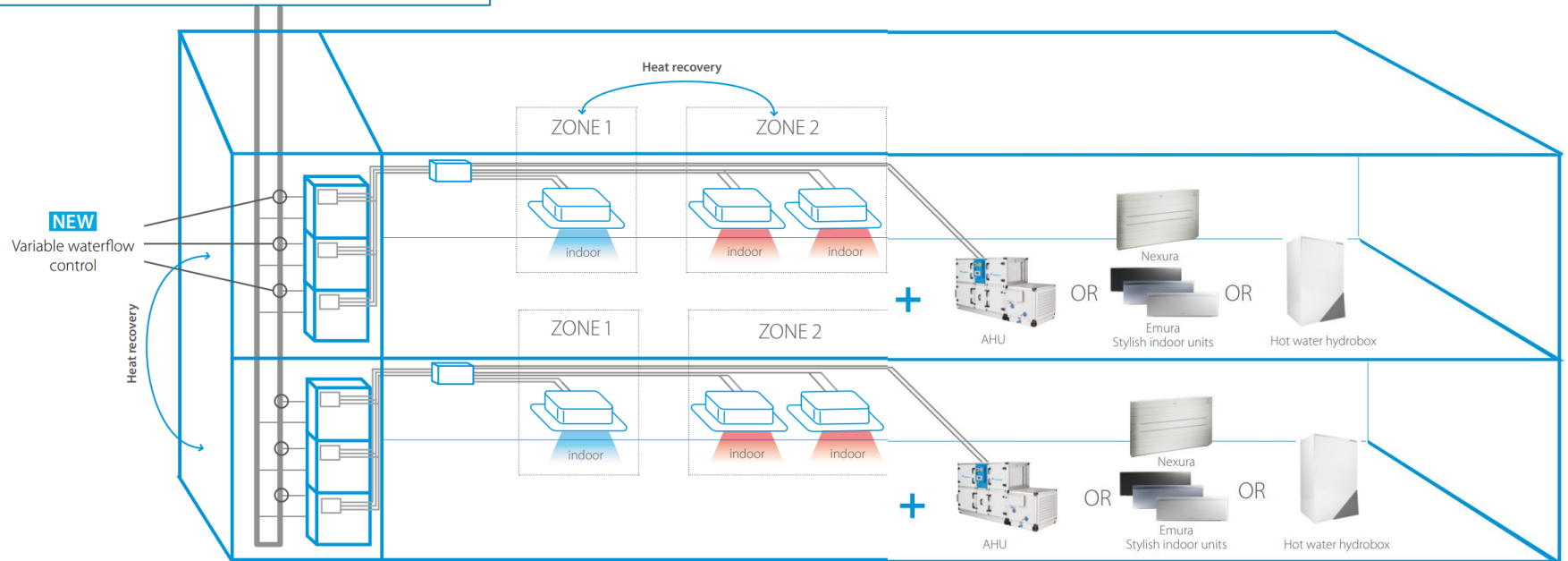

AIR TO AIR CHILLER

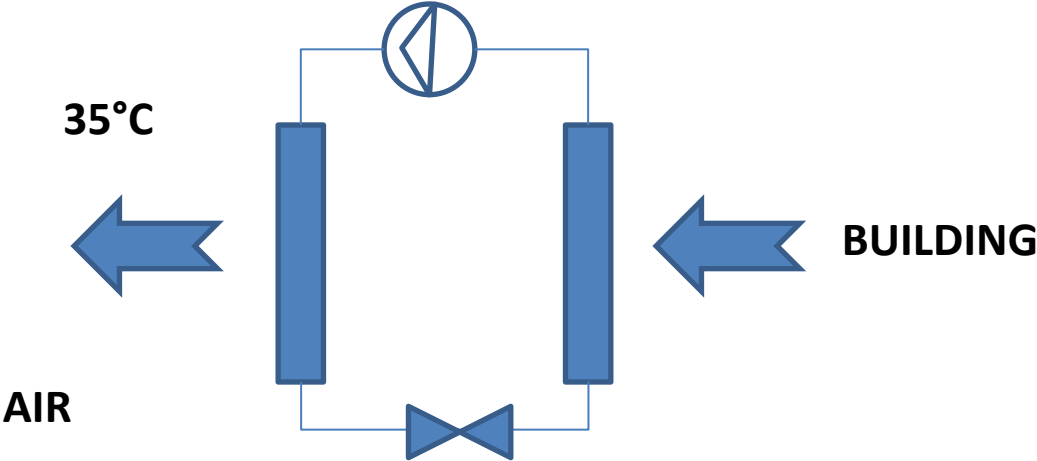

Air-water systems with heat pumps: heating

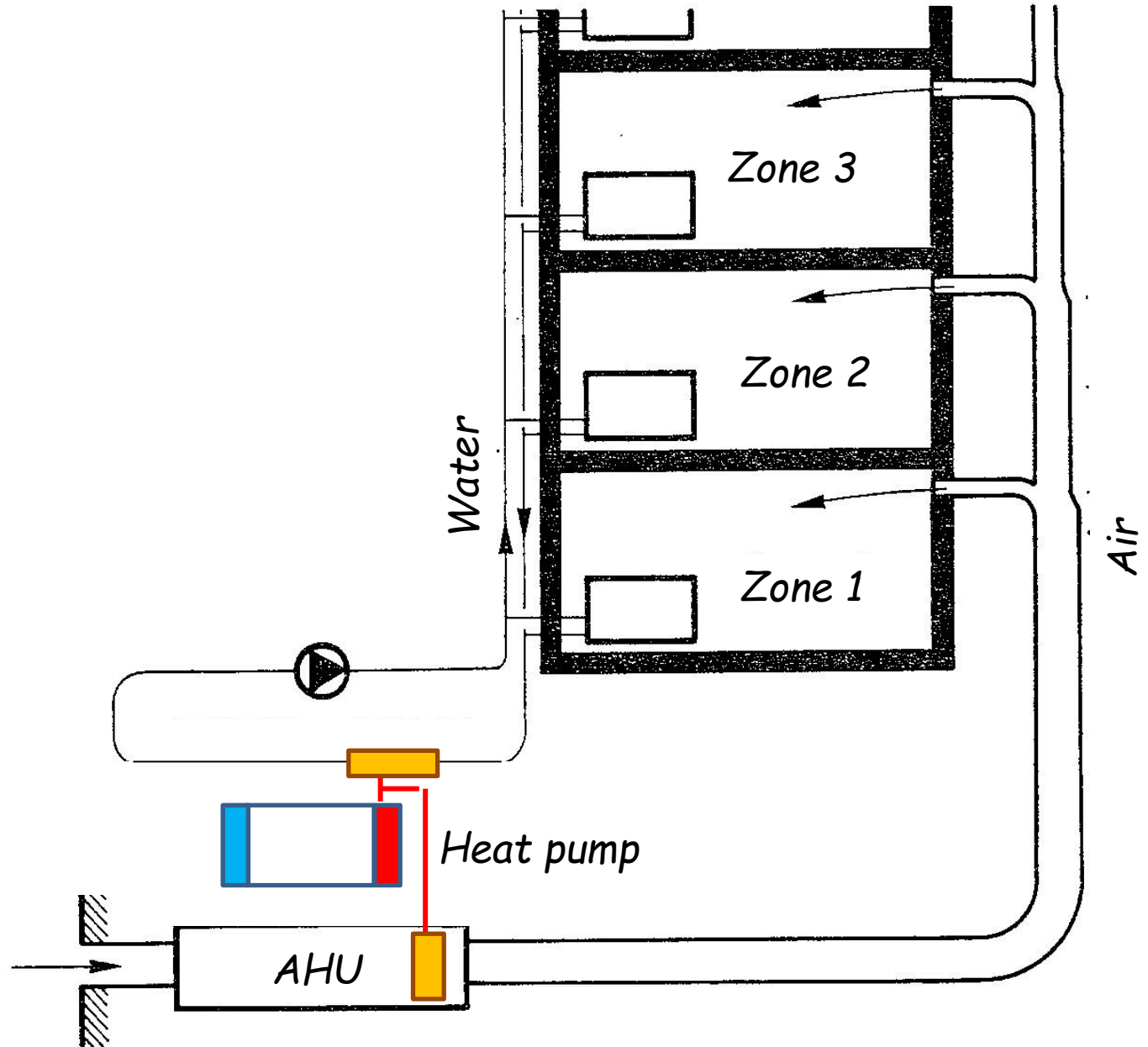

Air-water systems with heat pumps: cooling

Heat recovery:
condensation heat
for the reheat coils

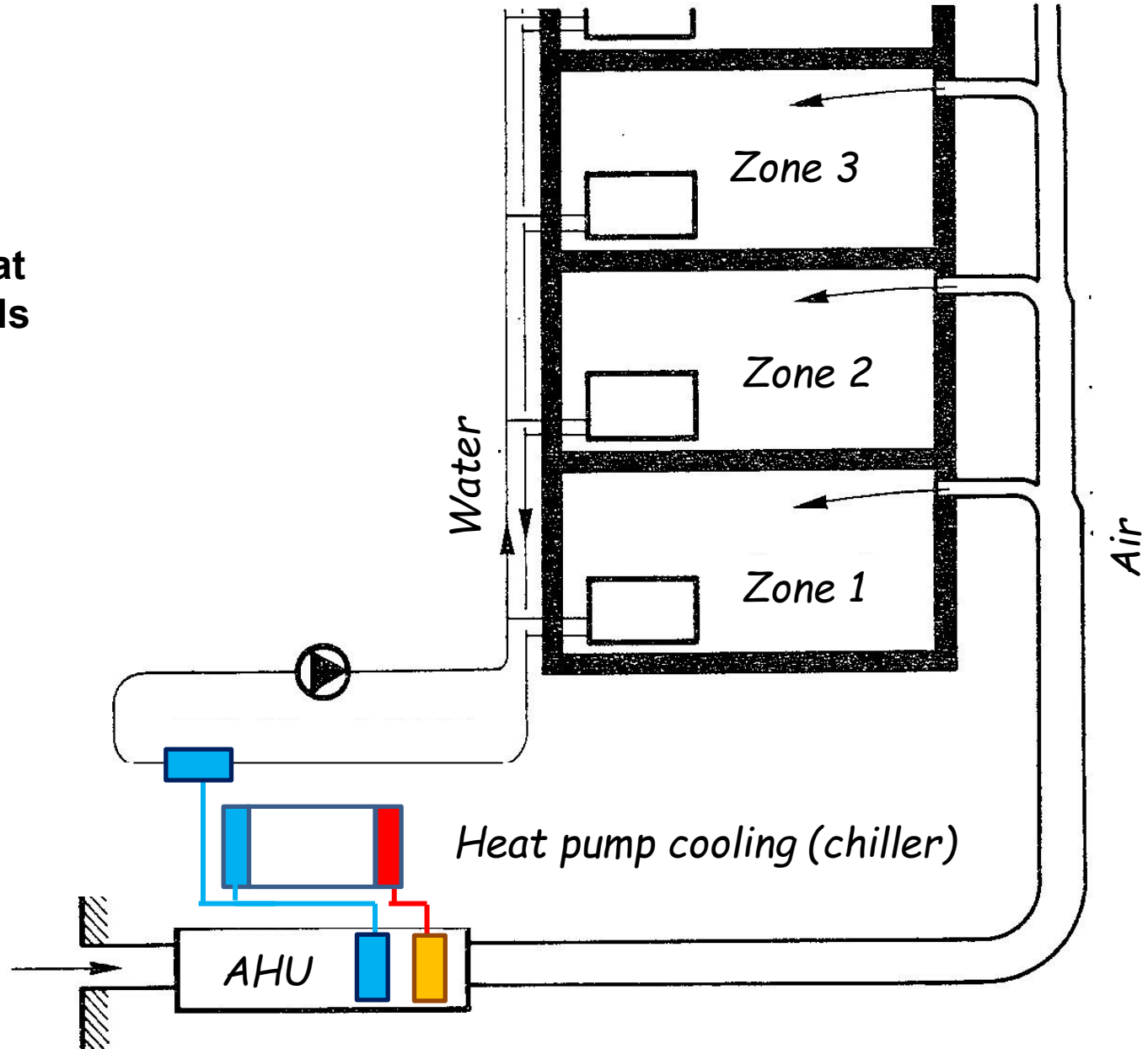

Air-water systems with heat pumps: cooling

Two levels of evaporating temperatures in cooling: two different generators or via cooling storage

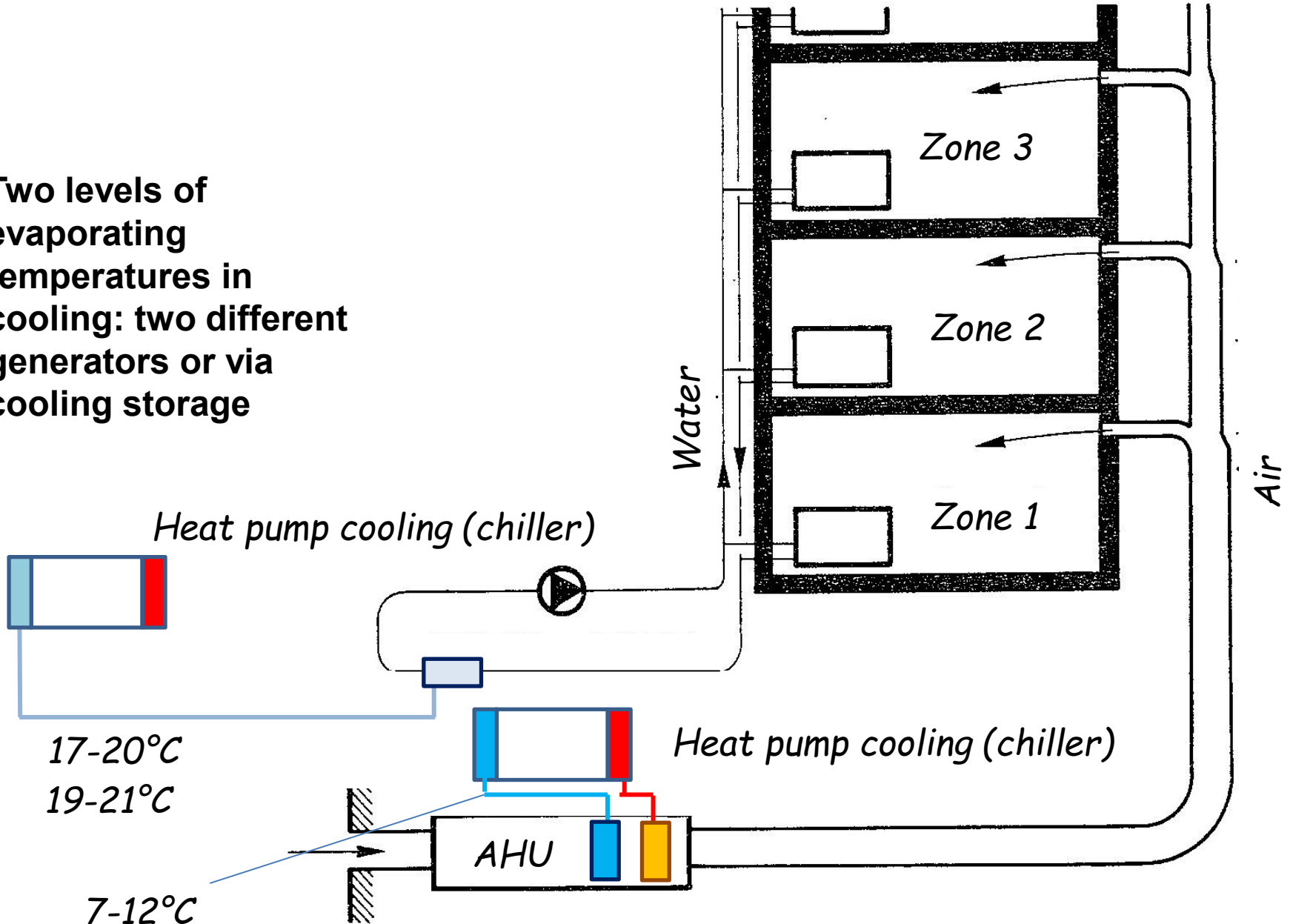

Example of energy storage in cooling: TABS (Thermo-Active Building System)

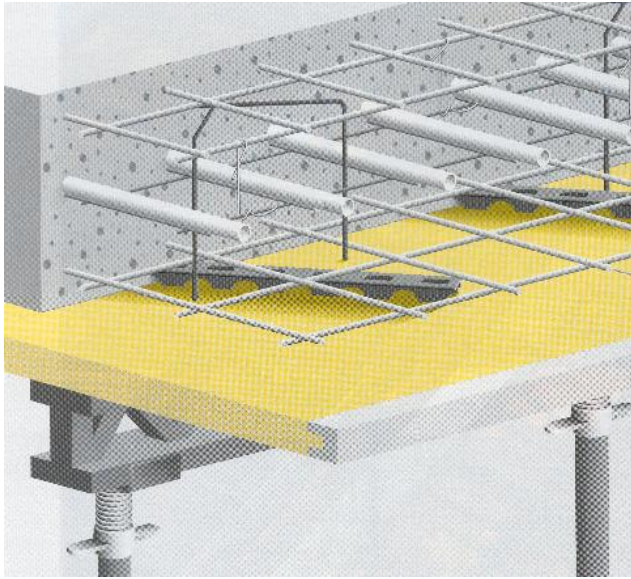

Pipes are embedded in the full concrete slab used also for structural purpose. It is also possible to use prefabricated elements easy to install on site.

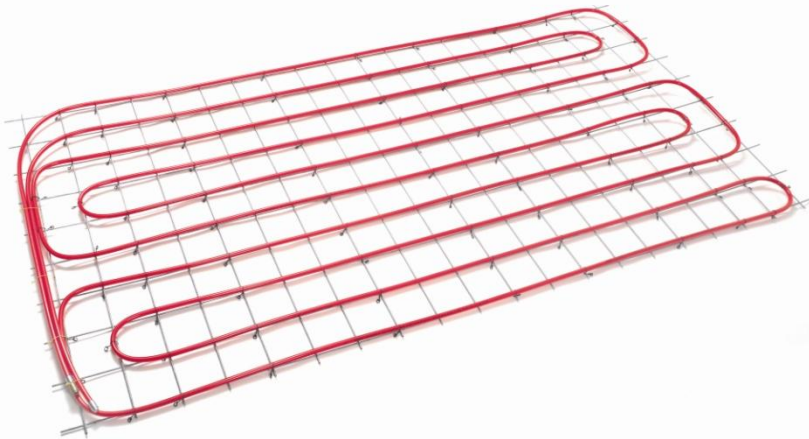

Principle of operation of the TABS (Thermo-Active Building System)

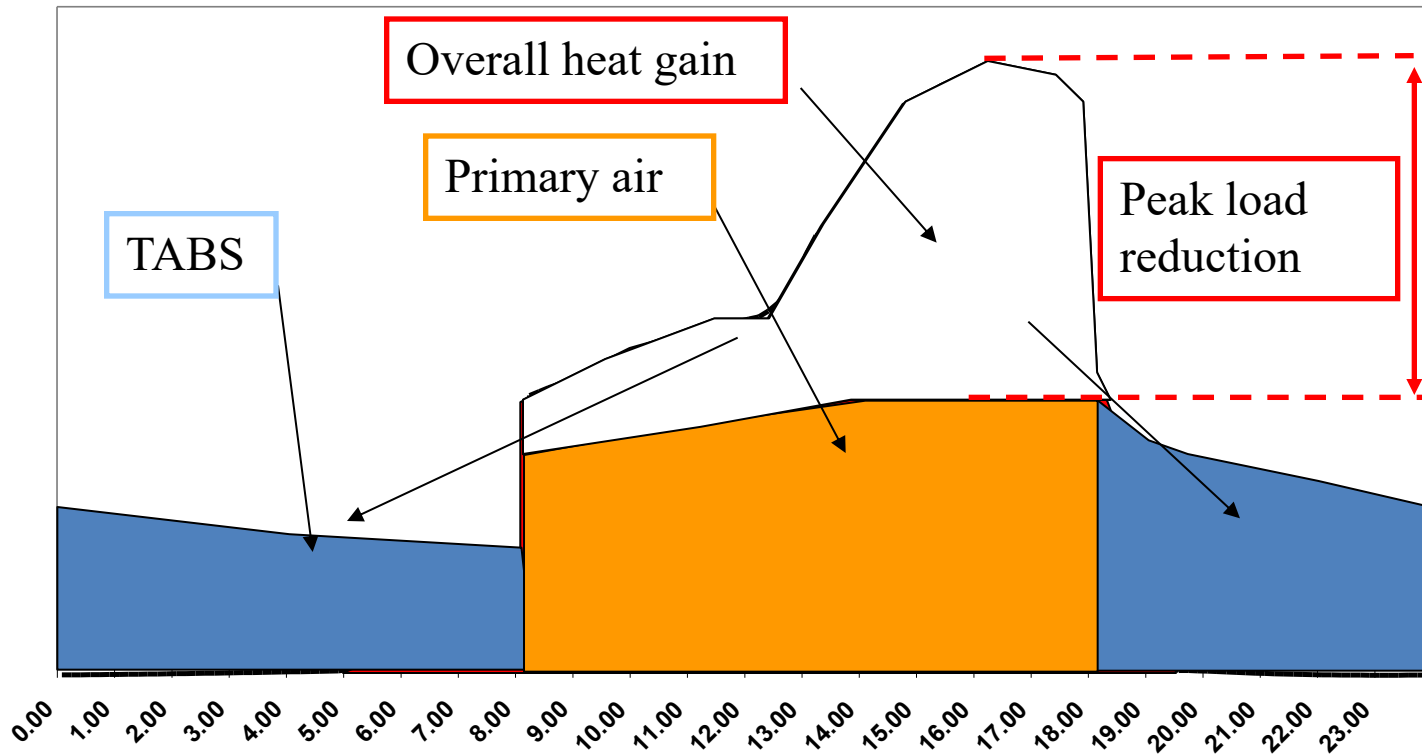

Indoor conditions during a summer day

EXAMPLE OF INTERNAL CONDITIONS WITH THERMAL SLAB

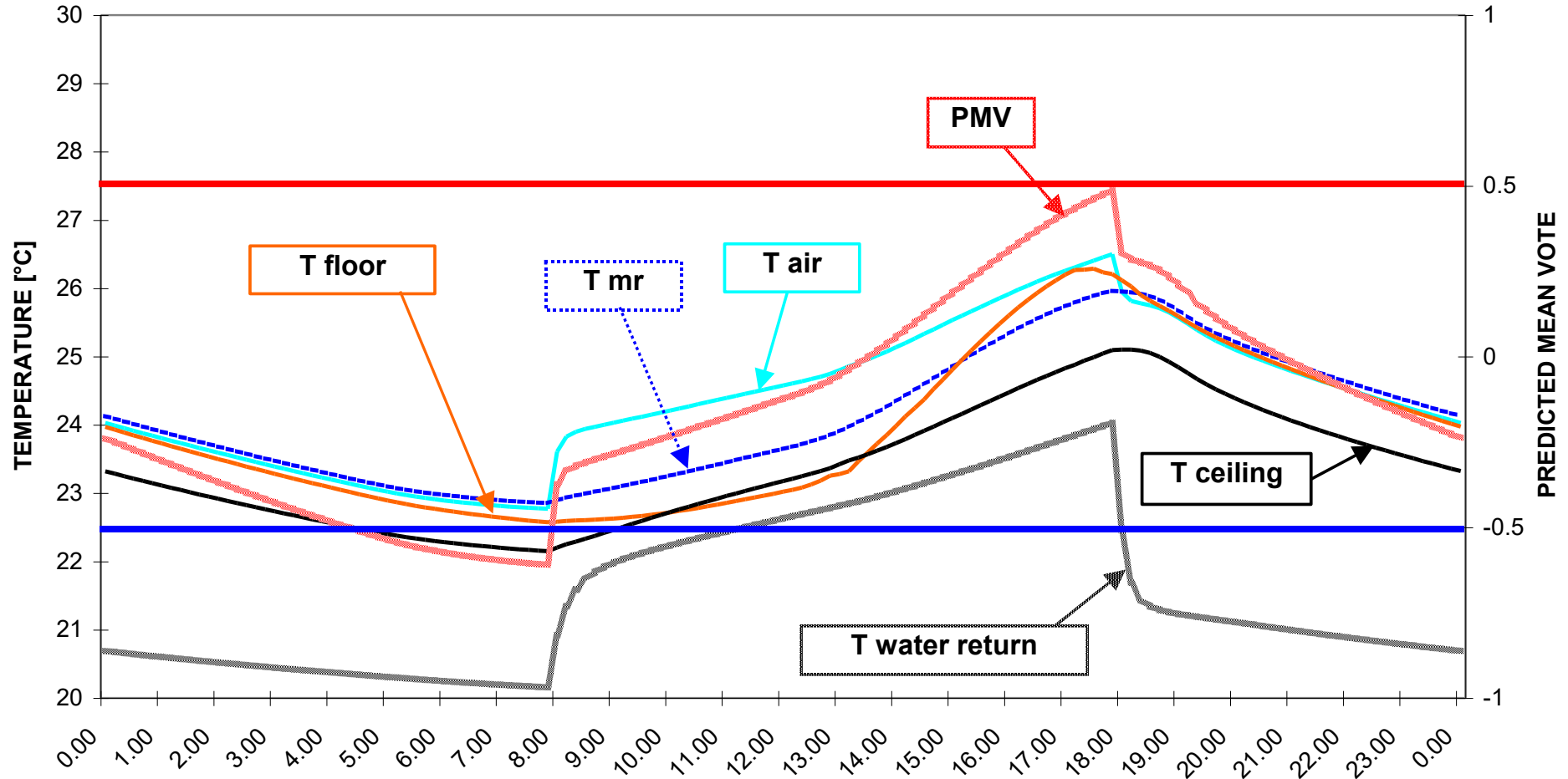

Advantages

- Low temperature difference between water and room
- Limit in the peak power
- Possibility to operate at 2 different levels of temperatures (high COP during night)
- Working overnight electric energy could be cheaper

Critical aspects

- Optimization of the envelope (max. heat gain circa 55-60 W/m²)
- Weight of structures
- Need to use dynamic simulations for fine tune sizing

choice of TABS

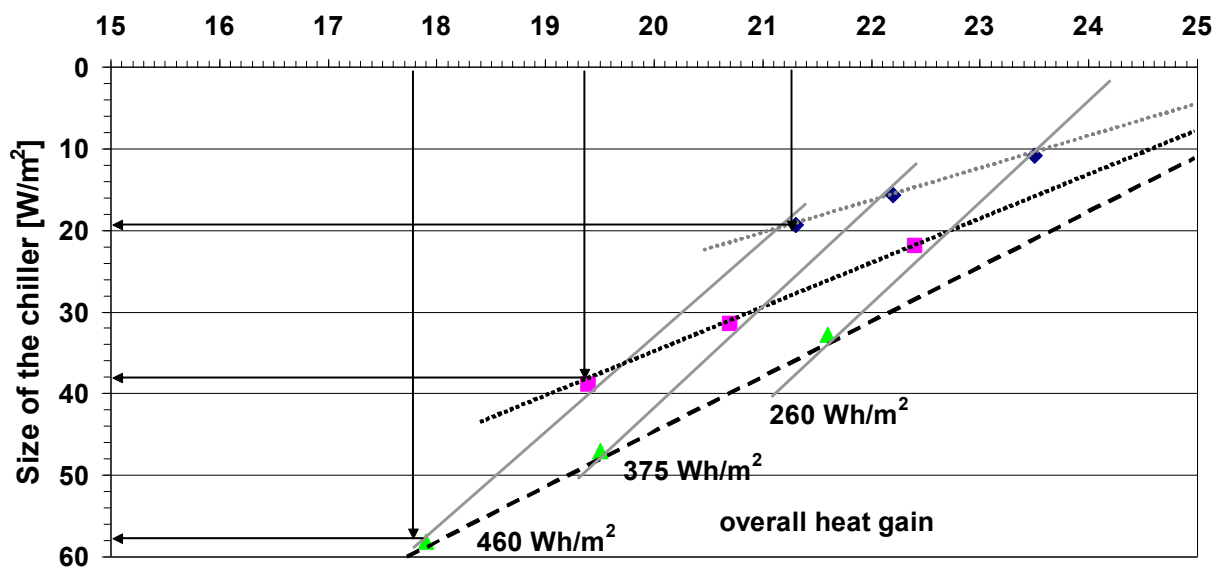
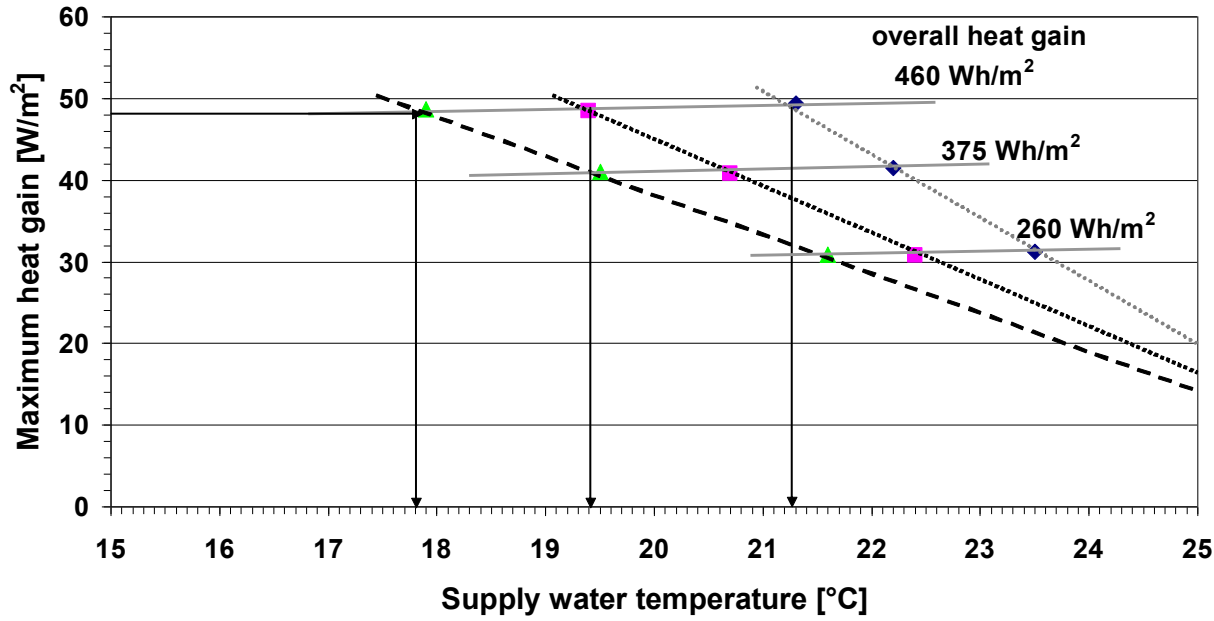

Another interesting application: radiant floor + displacement ventilation in large buildings

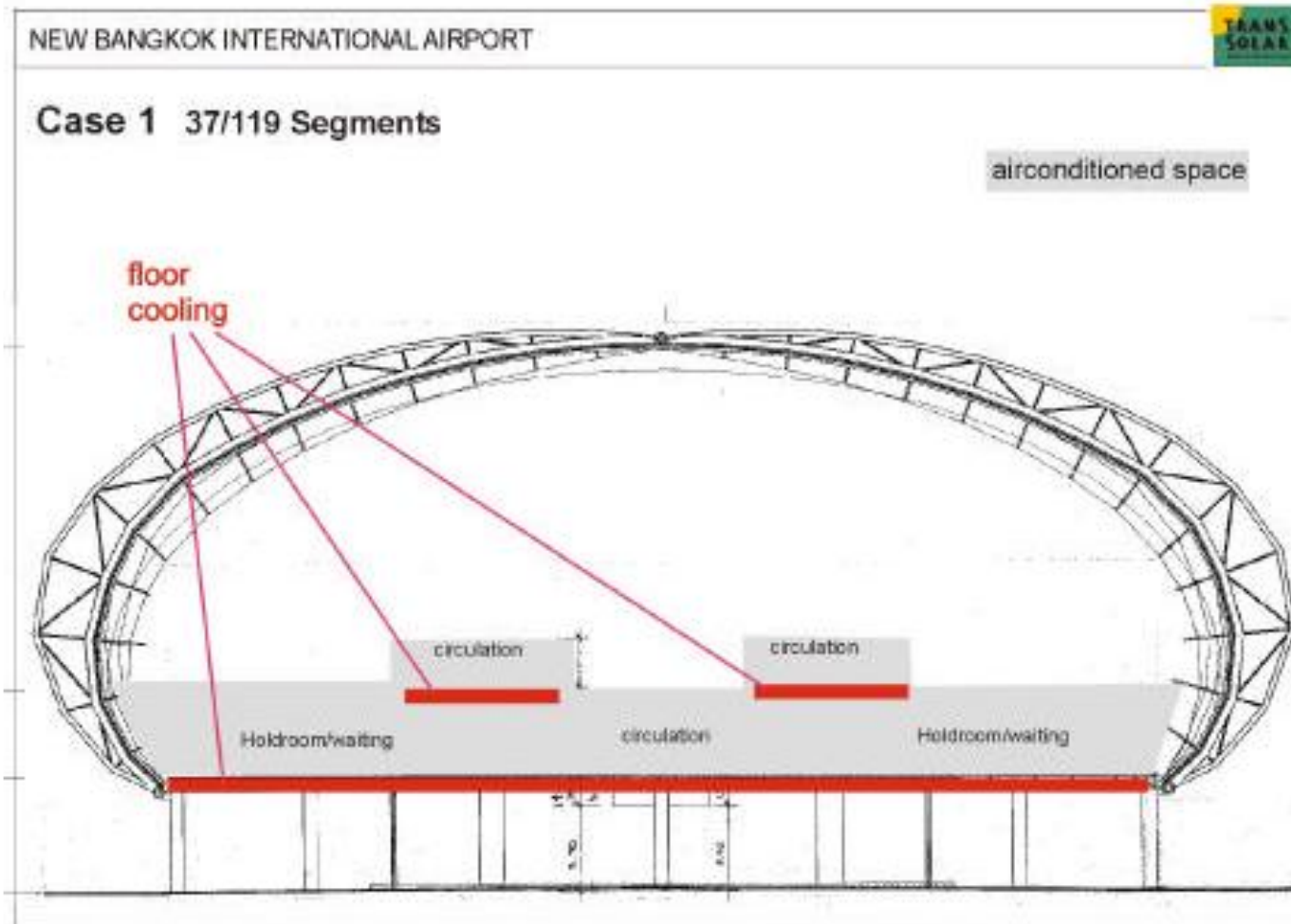

Optimized energy concept concourses

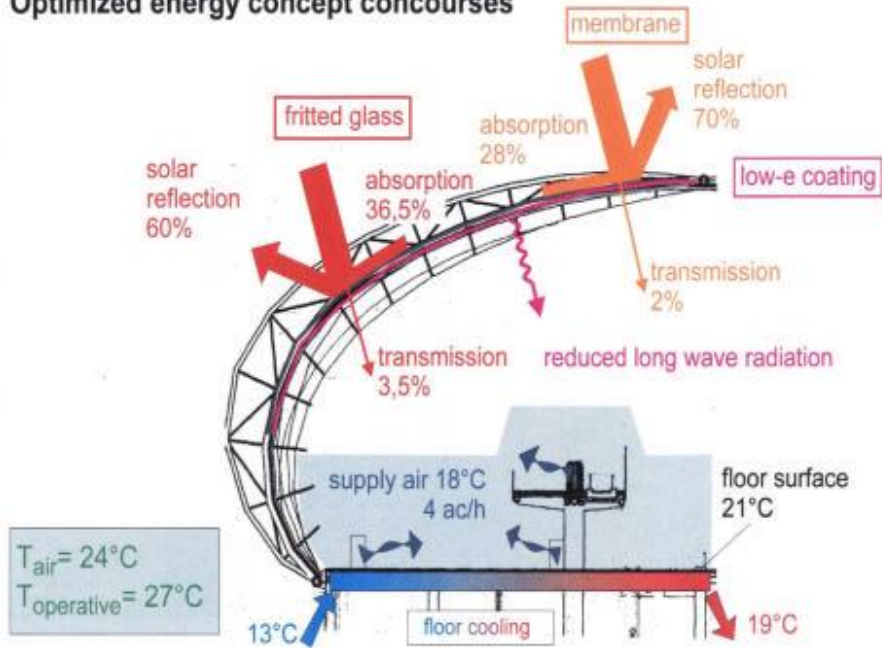

Energy saving: 30%

NEW BANGKOK INTERNATIONAL AIRPORT



Comparison of Cooling loads entire Airport

Original Concept

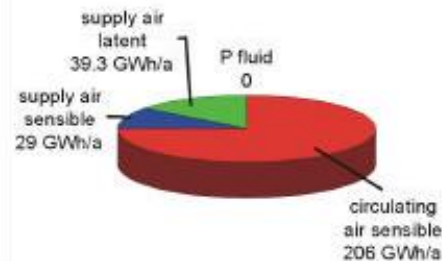

total load: 275 GWh/a
739 kWh/m²a

Optimized Concept

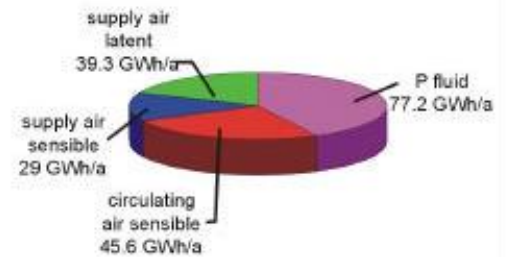

total load: 191 GWh/a
513 kWh/m²a

Air-Air systems with full air: rooftop solutions (heating)

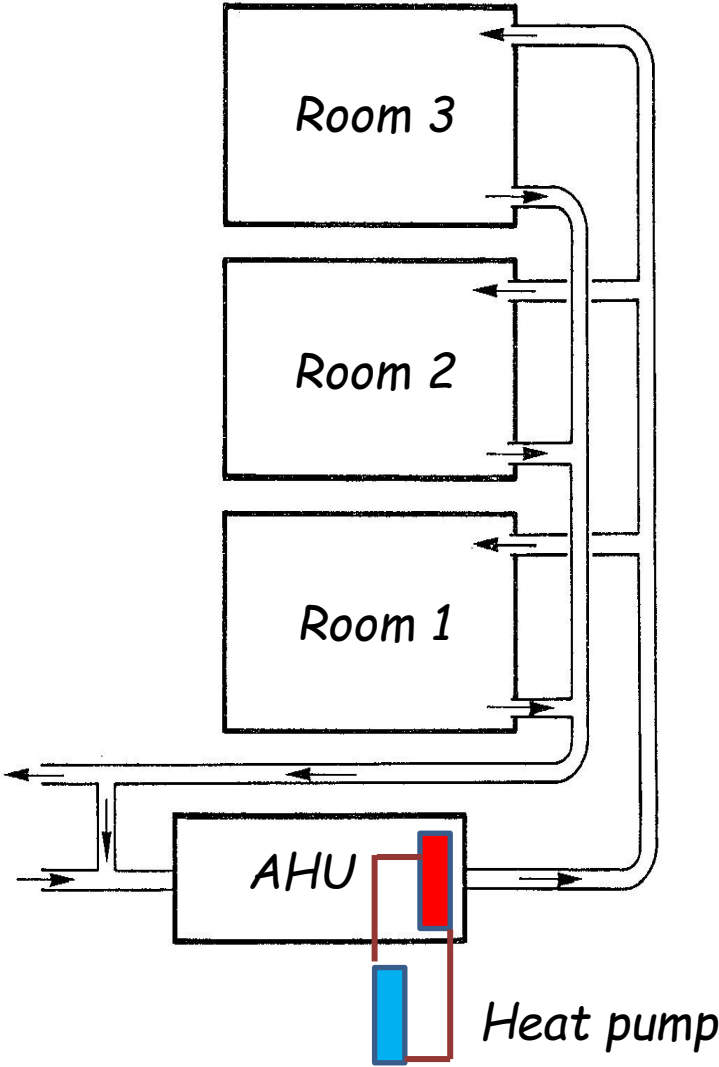

Air-Air systems with full air: rooftop solutions (Cooling)

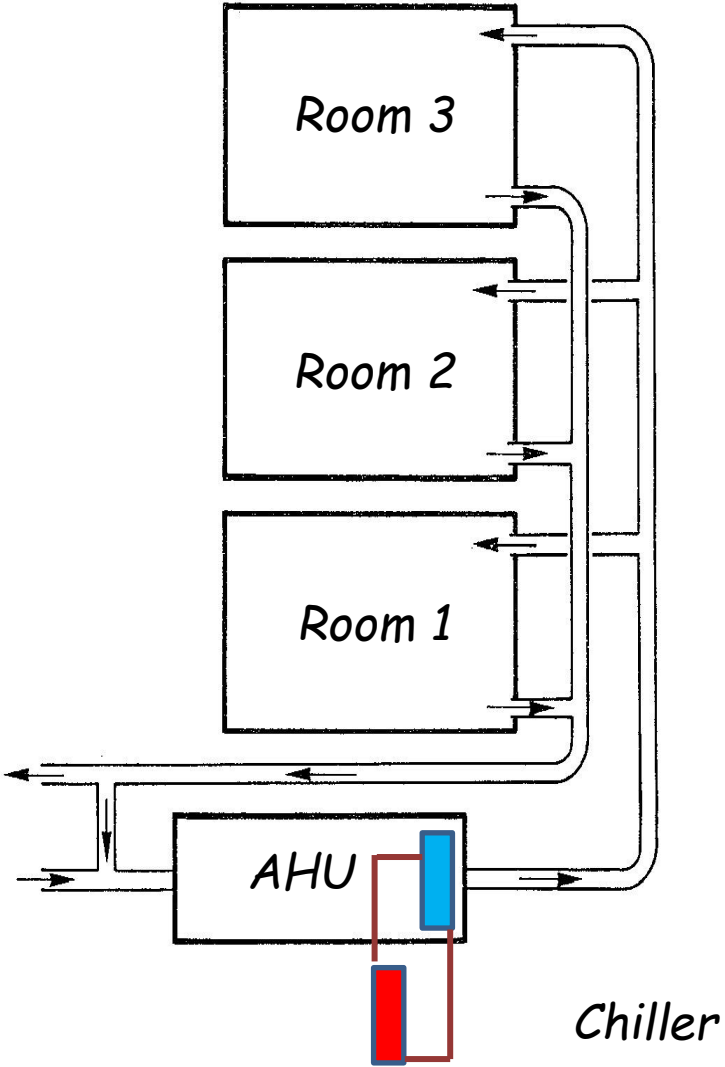

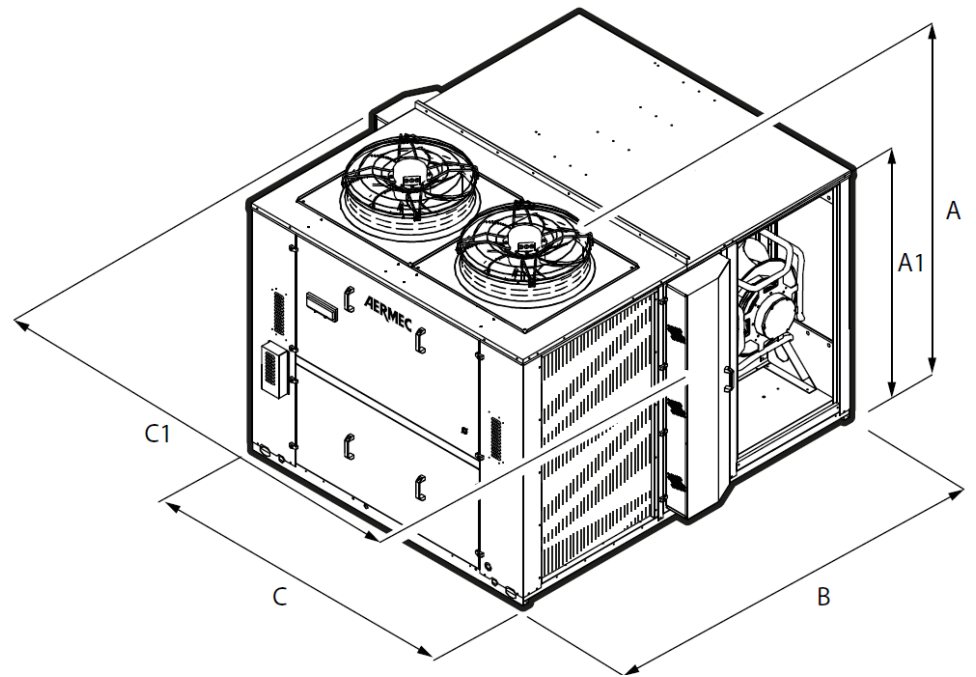

ABSORPTION CYCLES

Cooling cycle:

$$\text{Efficiency} = \frac{Q_{\text{evaporator}}}{Q_{\text{absorbed}}}$$

Heating cycle:

$$\text{Efficiency} = \frac{Q_{\text{condenser}}}{Q_{\text{absorbed}}}$$

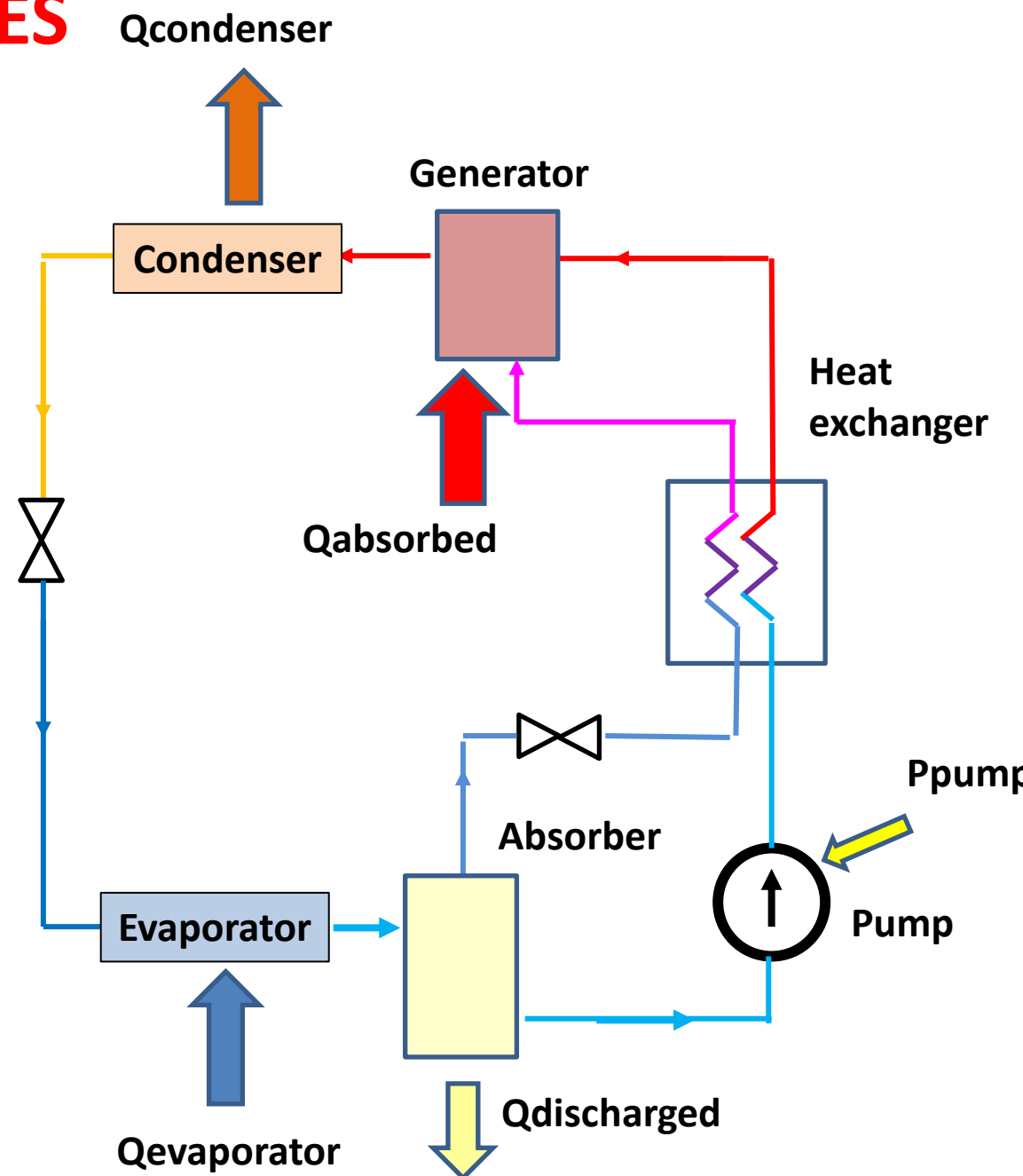

ABSORPTION CHILLERS



Absorption chillers are able to use hot temperature source.

This can be solar thermal energy, energy waste, heat rejected by a cogenerator (trigeneration).

Usually the most common compound is Lithium Bromide (LiBr) coupled with water.

Usually the minimum temperature of the source should be 90°C.

The efficiency is related to the type of cycle; usually single stage machines are used with a typical value of COP = 0.7

These system can work only in cooling. In heating they are not able to operate as heat pumps.

ABSORPTION HEAT PUMP

Absorption heat pumps are mainly working today with natural gas. .
Usually the most common mixture is water-ammonia.

$$GUE = \frac{Q_{\text{condenser}}}{Q_{\text{absorbed}}}$$

The typical efficiency is $GUE = 1.4$

These systems are optimized for working in heating conditions. They can work also in cooling conditions, but usually in cooling the performance is poor.

