

Terminal units

Michele De Carli

Types of plants

Heat carrier fluid:

- 1. All air plants*
- 2. Water based systems*
 - Two pipes, four pipes*
- 3. Air-water plants*
- 4. High temperature radiant systems*
- 5. Direct expansion systems*

Type of service:

- Just heating*
- Just cooling*
- Heating and cooling*

1. All air systems

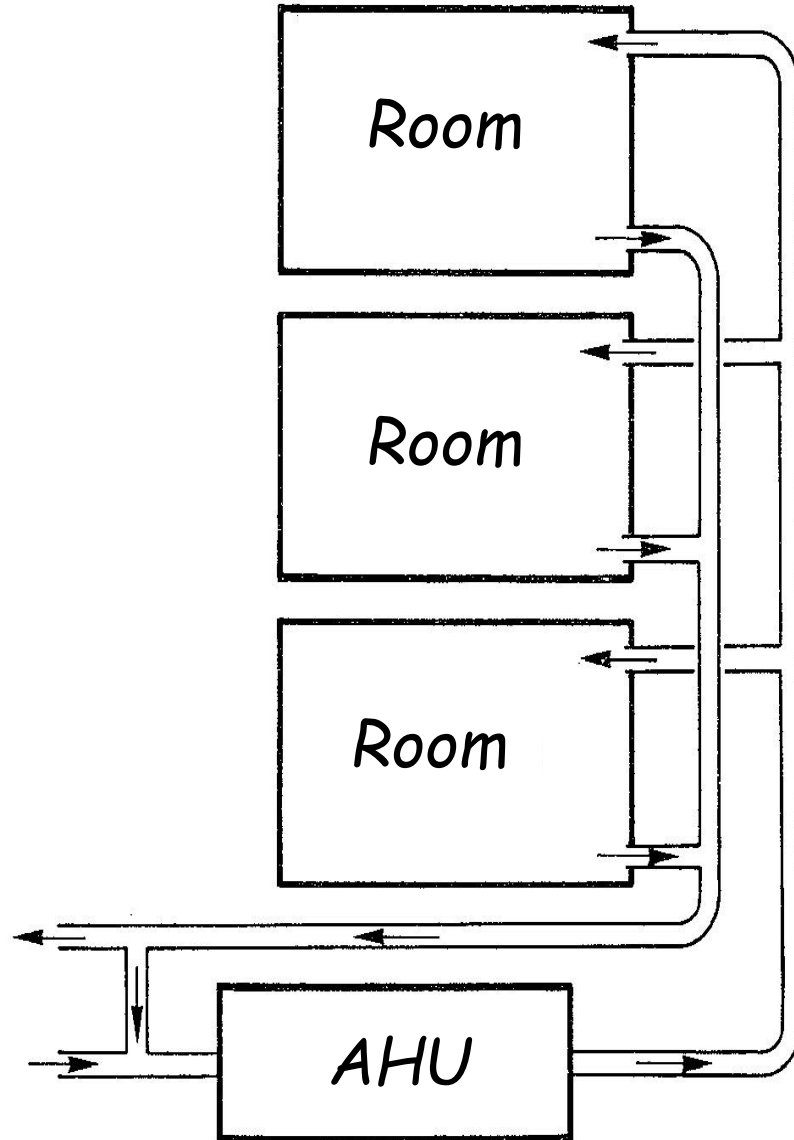

2. Water based systems

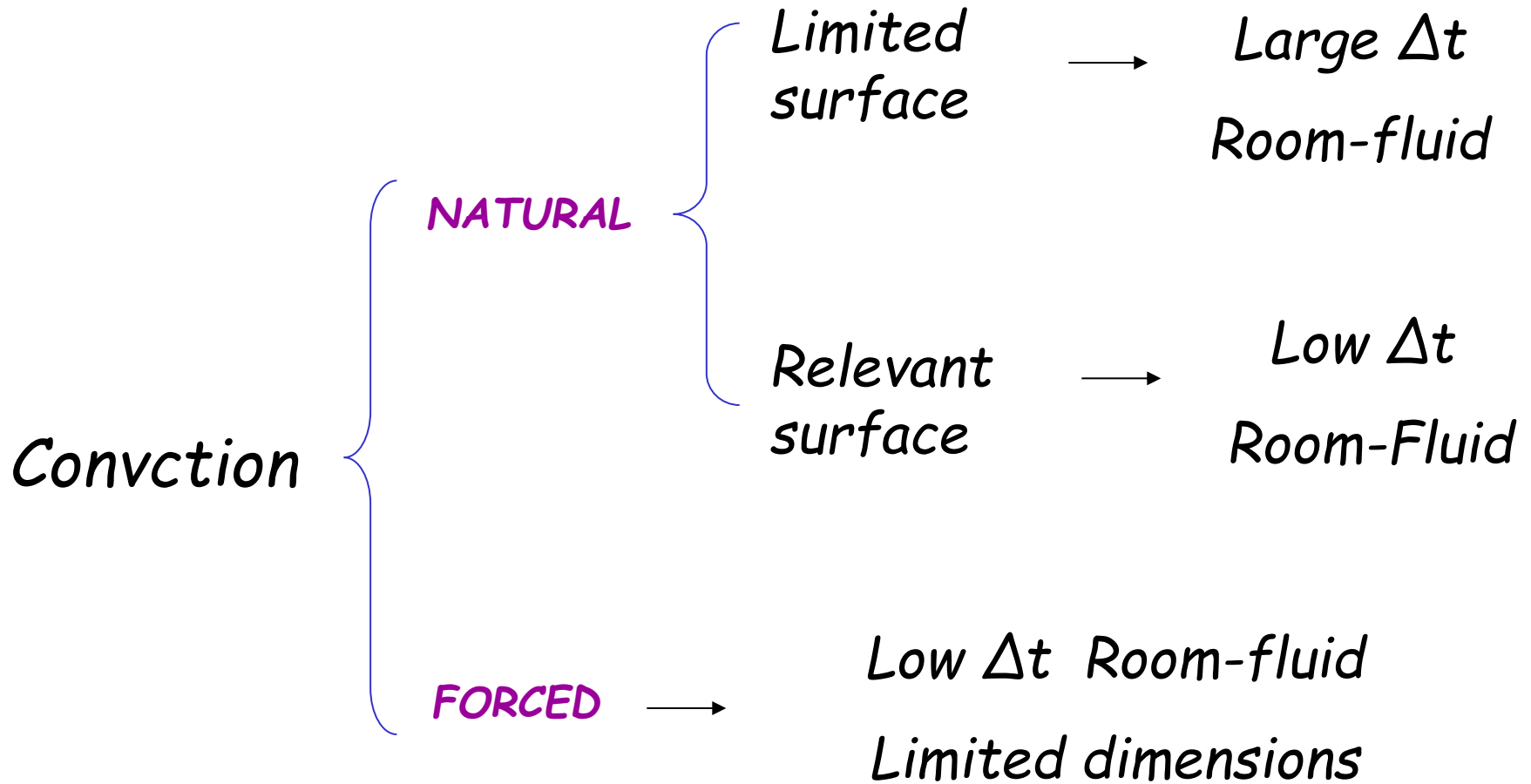

Two pipes plant

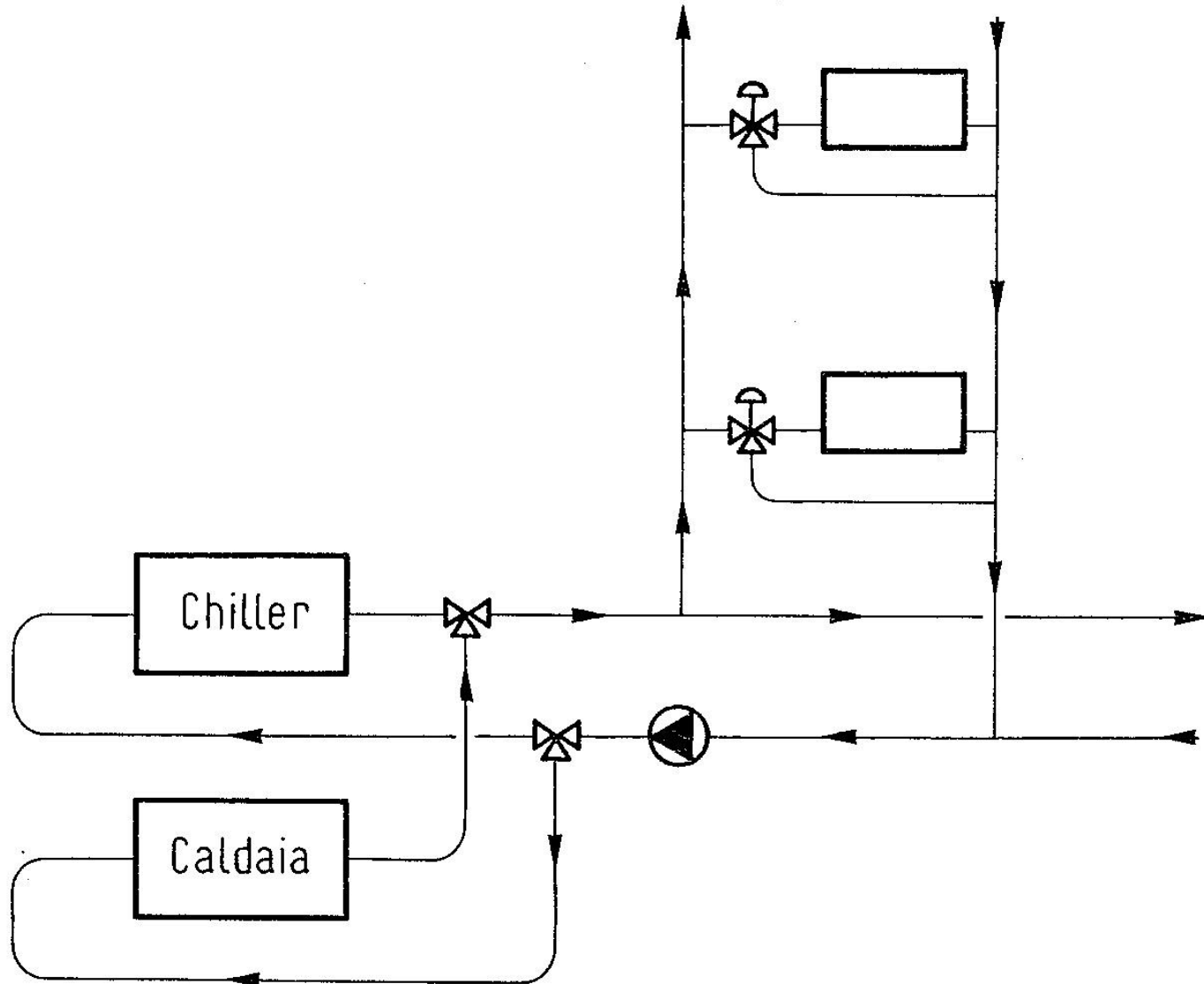

Four pipes plant

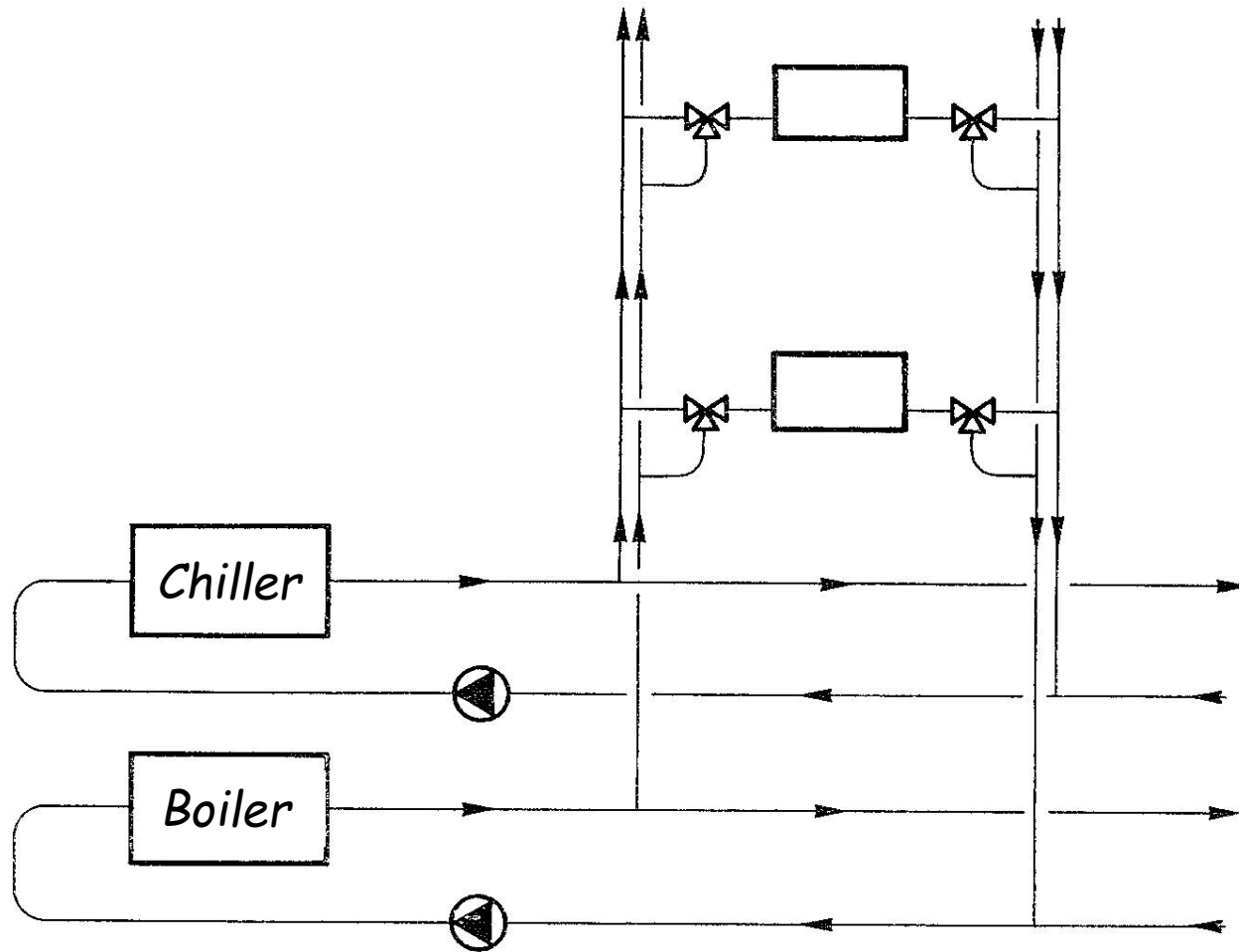

Two 3-way valves or 2 different coils

Warmed water

Chilled water

Four pipes plant

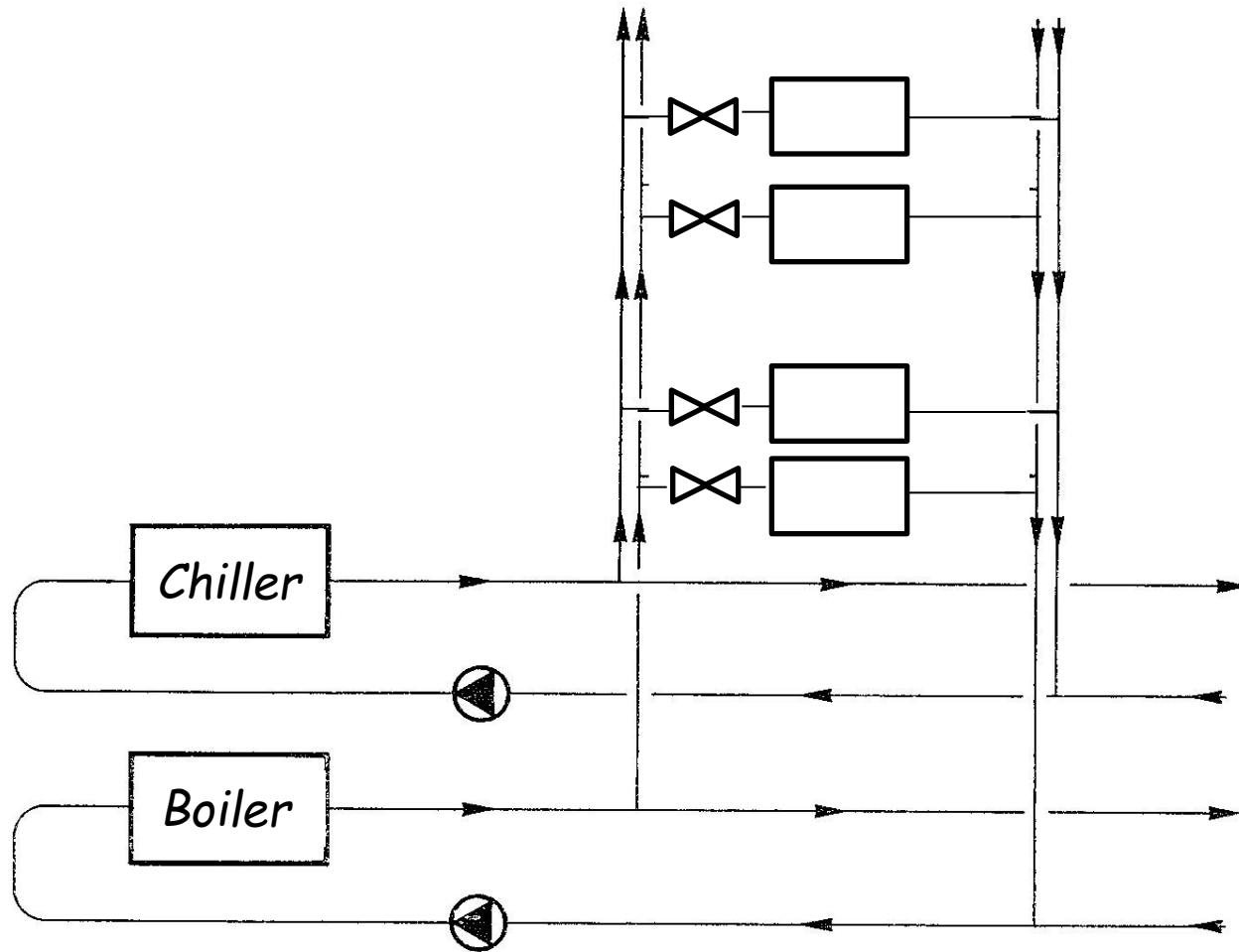

Two 3-way valves or 2 different coils

Warmed water

Chilled water

3. Air-water system



AIR

Vapour balance in the room



WATER

Sensible load

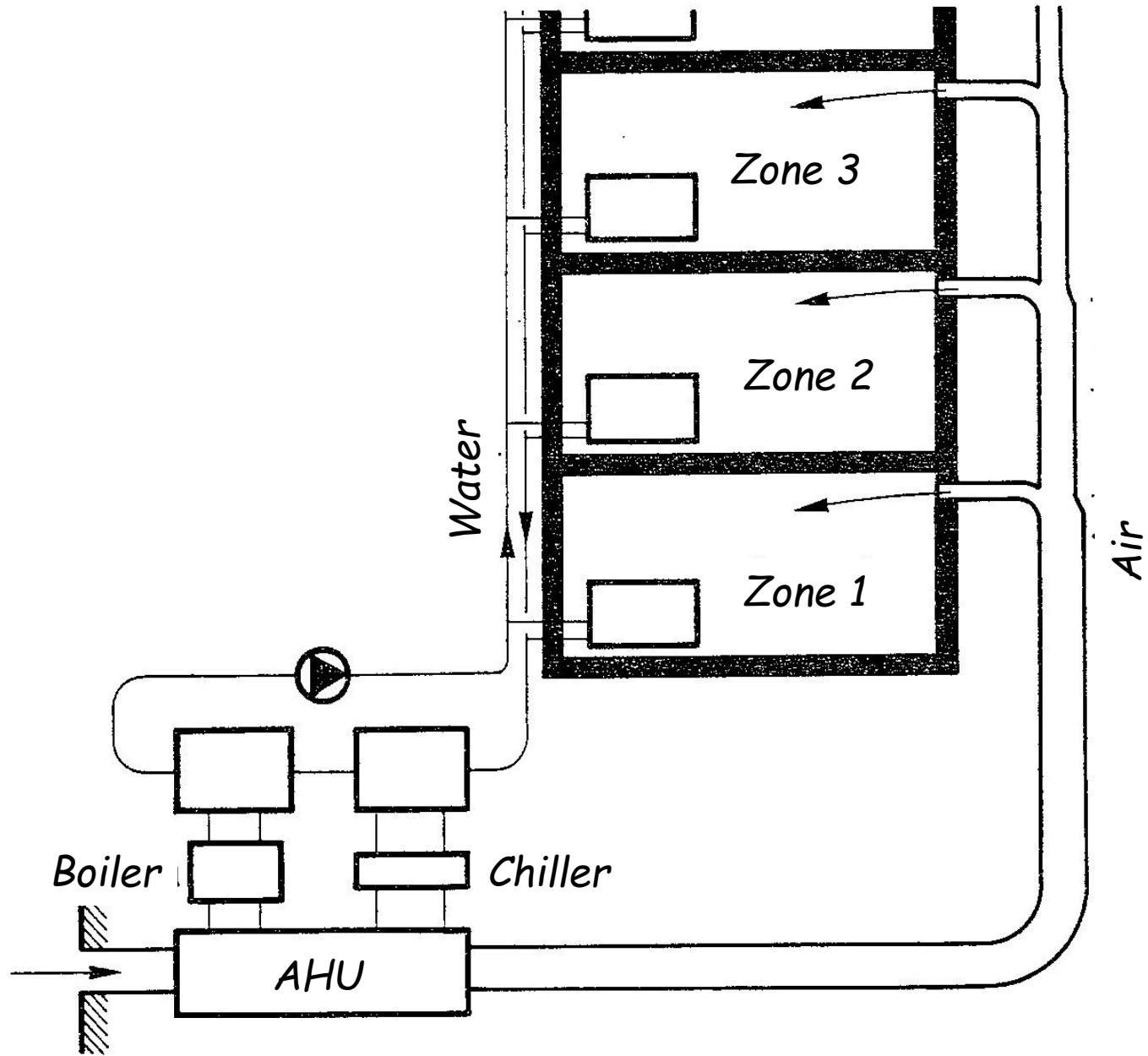

Radiant systems

Radiation from different surfaces

Ceiling ~ 28°C

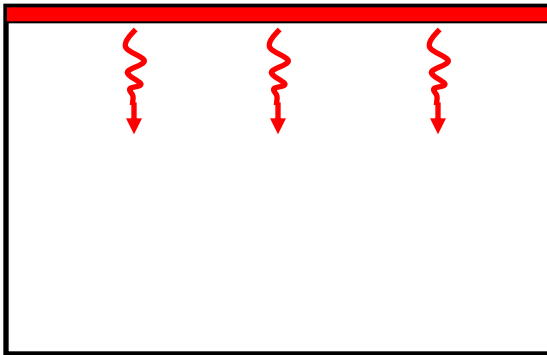

Floor ~ 26°C

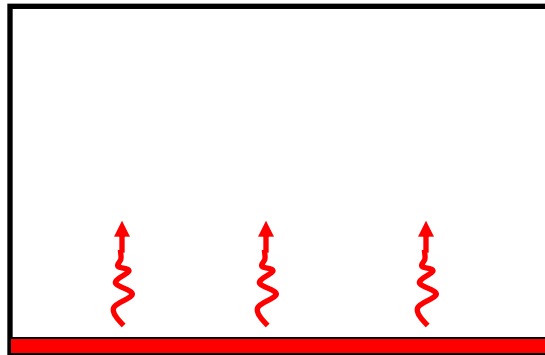

**Radiant element
~ 150 – 300 °C**

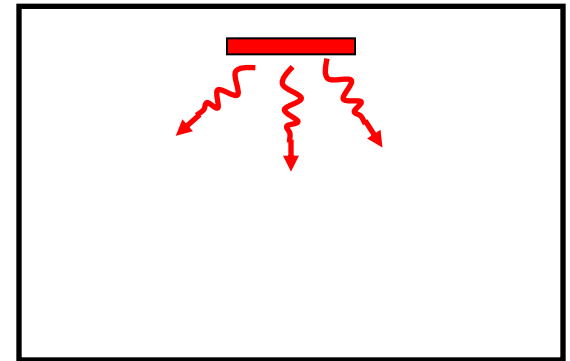

Let us consider a panel with surface temperature t_p and a room at 20°C

$$q / A = \sigma_n \varepsilon (T_p^4 - T_s^4)$$

t_p [°C]	T_p [K]	q/A [W/m ²]
28	300	43
50	322	180
100	372	613
200	472	2'181
400	672	10'101

Water based suspended radiant systems

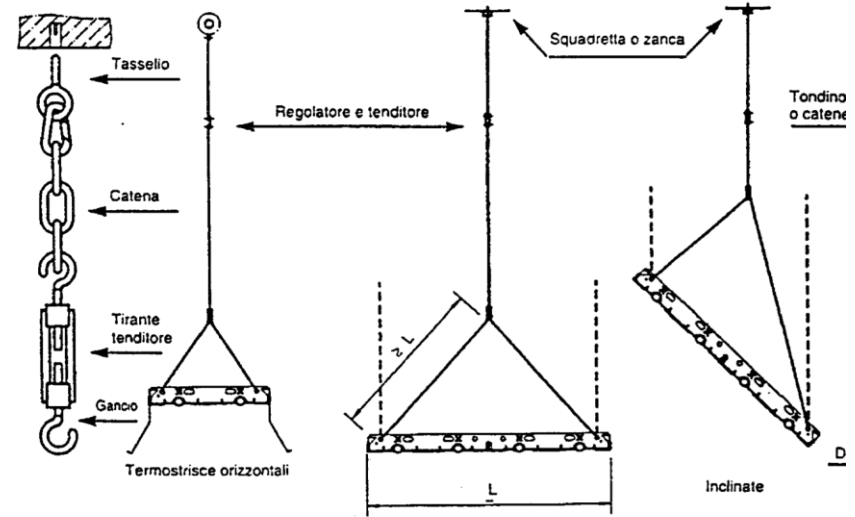
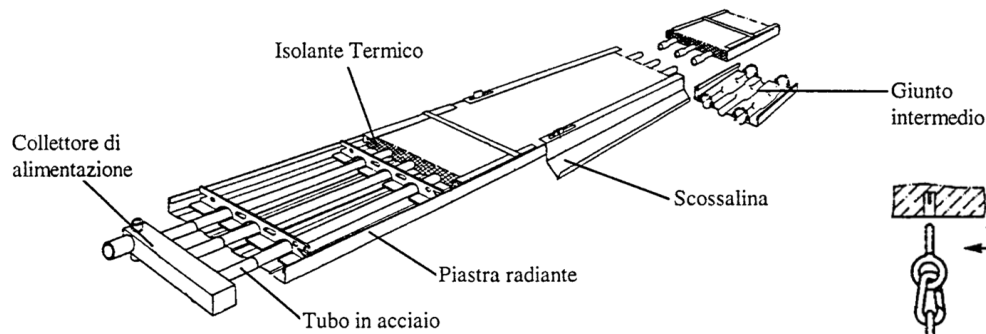

**Water at 90°C or pressurized water or vapour at 110-130°C.
Length from 4 m to 6 m.
Modular solution**

High temperature suspended radiant systems 1/2

Radiant tubes

The gas enters the combustion chamber with air providing combustion.

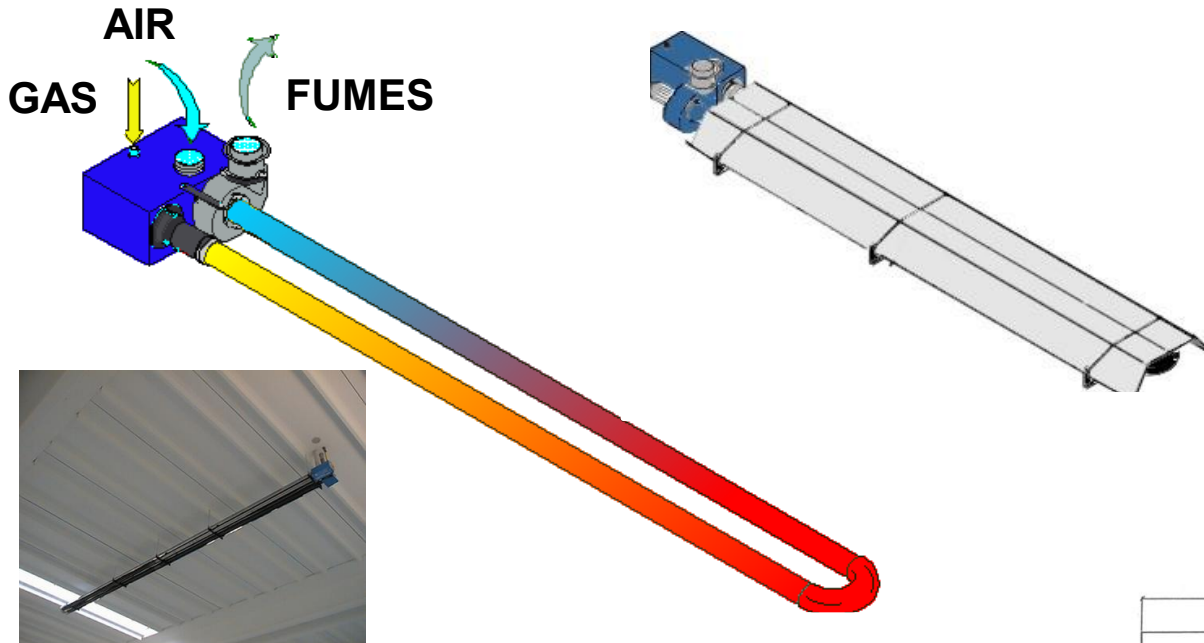

Combustion fumes flow inside the radiant tube and they exchange heat with the room.
Surface temperature 300°C-400°C
Length from 5 m to 15 m (from 15 to 50 kW).
The fan is installed on the exhaust soas to provide depression to avoid fumes in the room

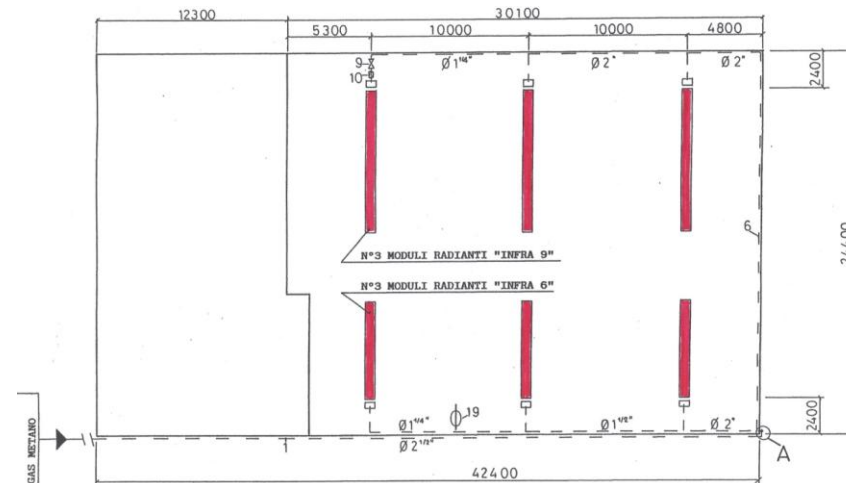

High temperature suspended radiant systems 2/2

Radiant strips

The gas enters the combustion chamber with air providing combustion as in radiant tubes. In this case there is a recirculation of fumes provided by Venturi effect.

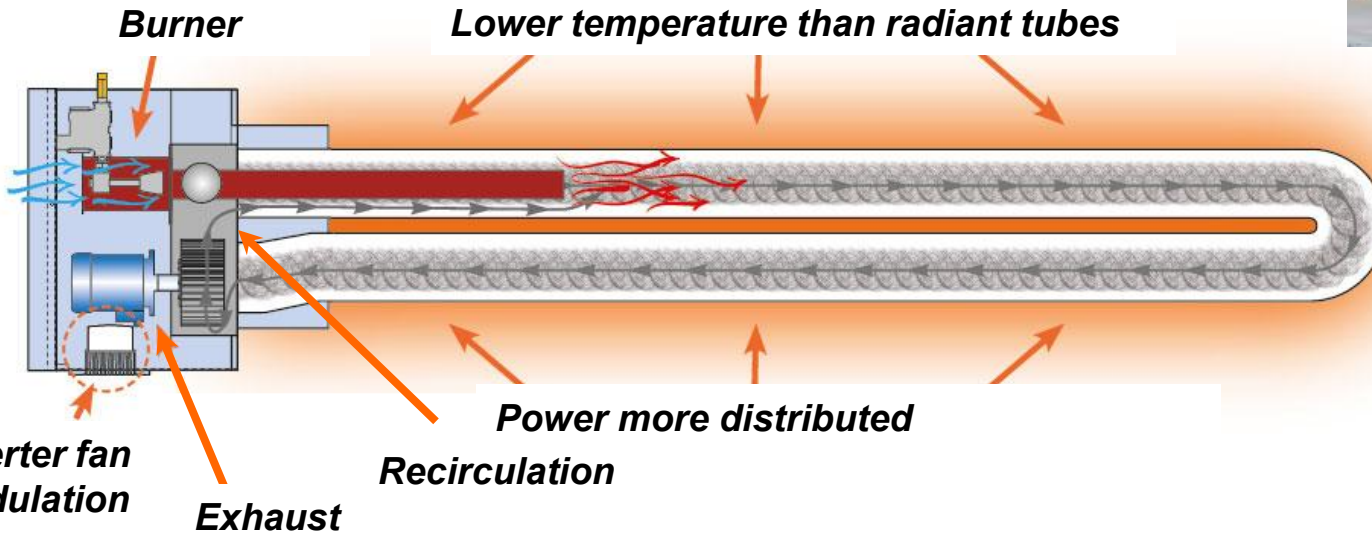

The length of a strip can be up to 140 m. There are 2 possible lay-outs

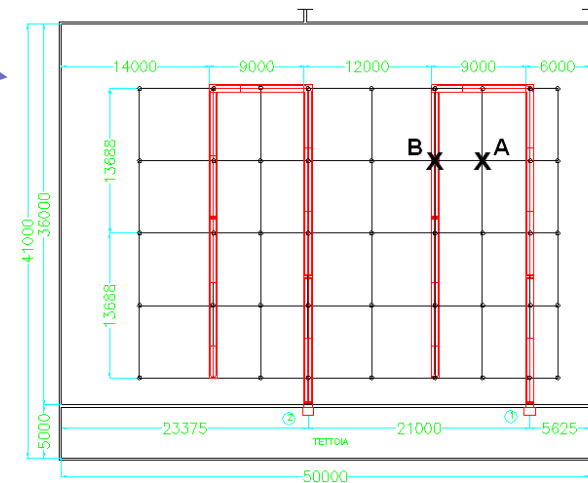
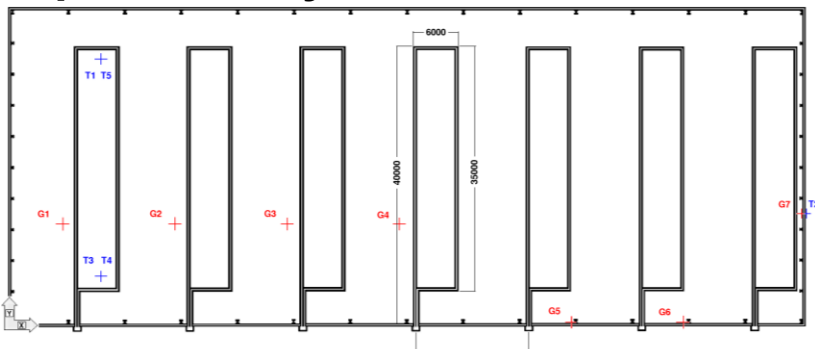

Radiant Luminous Systems

The combustion chamber is in the ambient (need of adequate ventilation or open spaces)

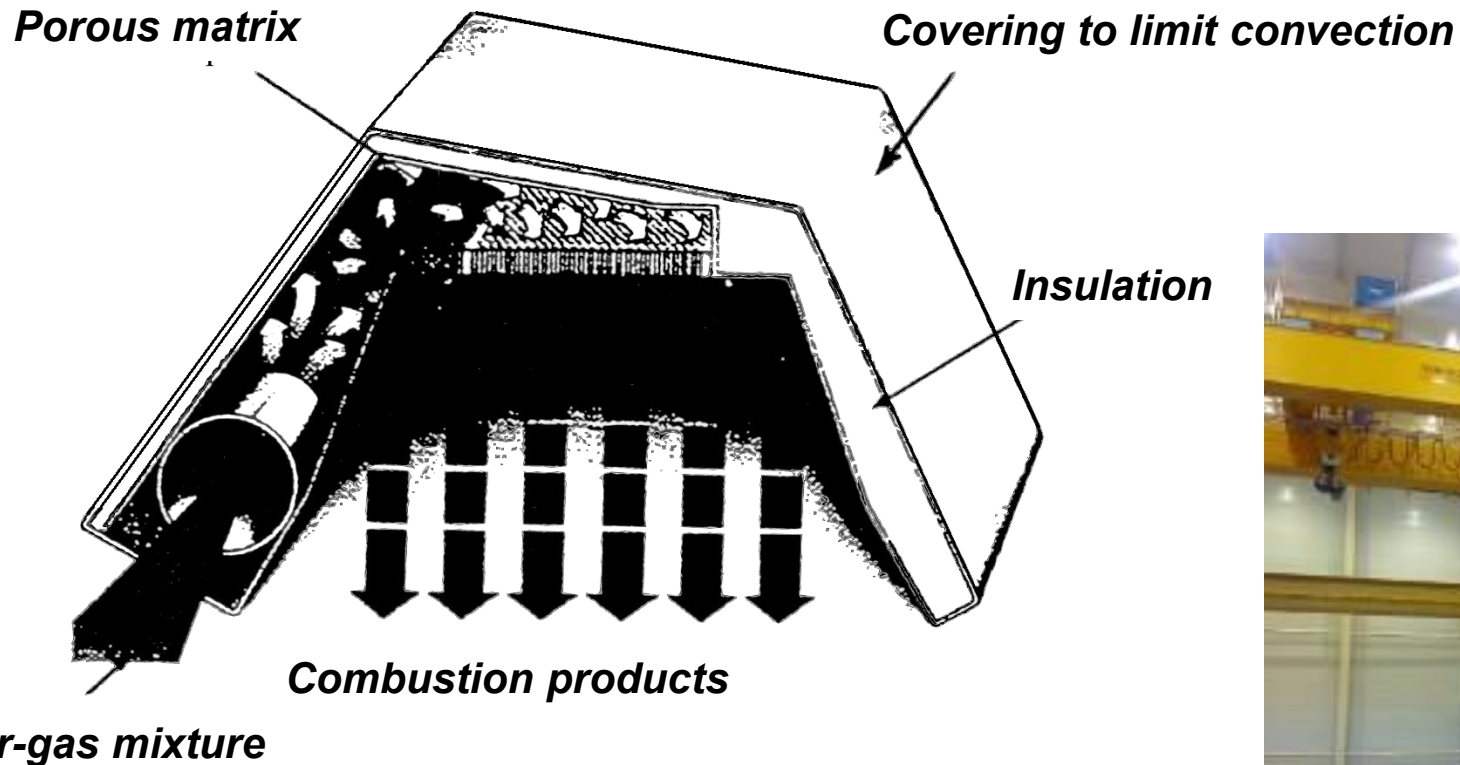

5. DIRECT EXPANSION UNITS

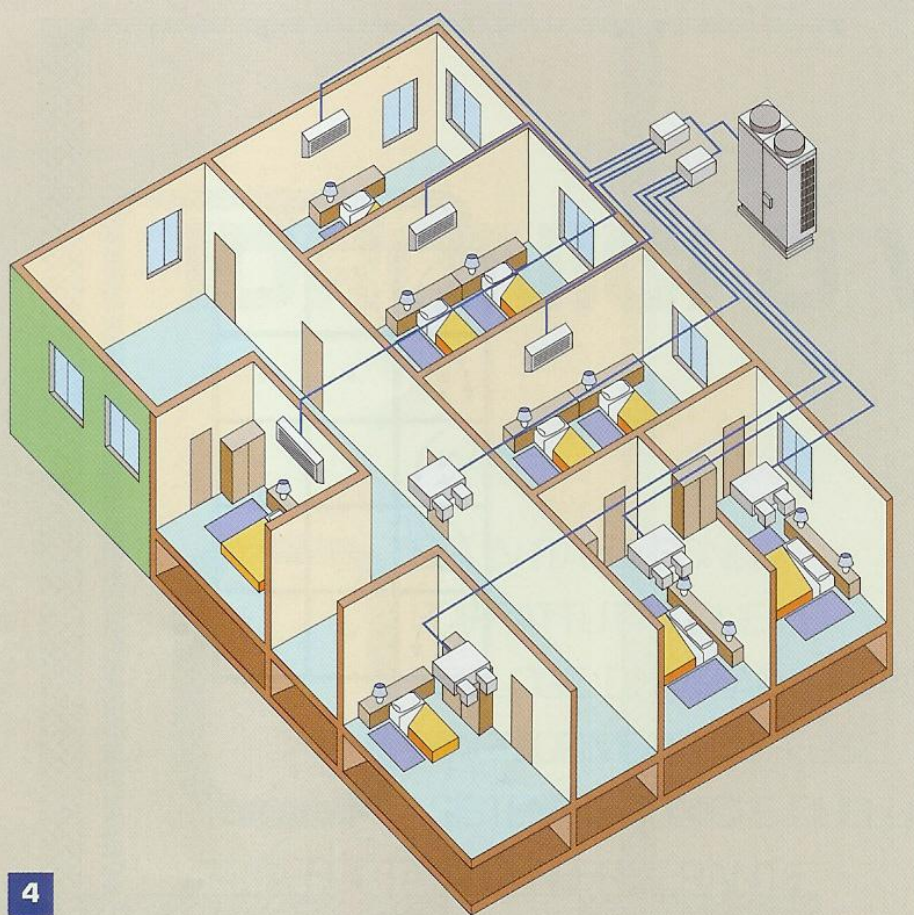

4

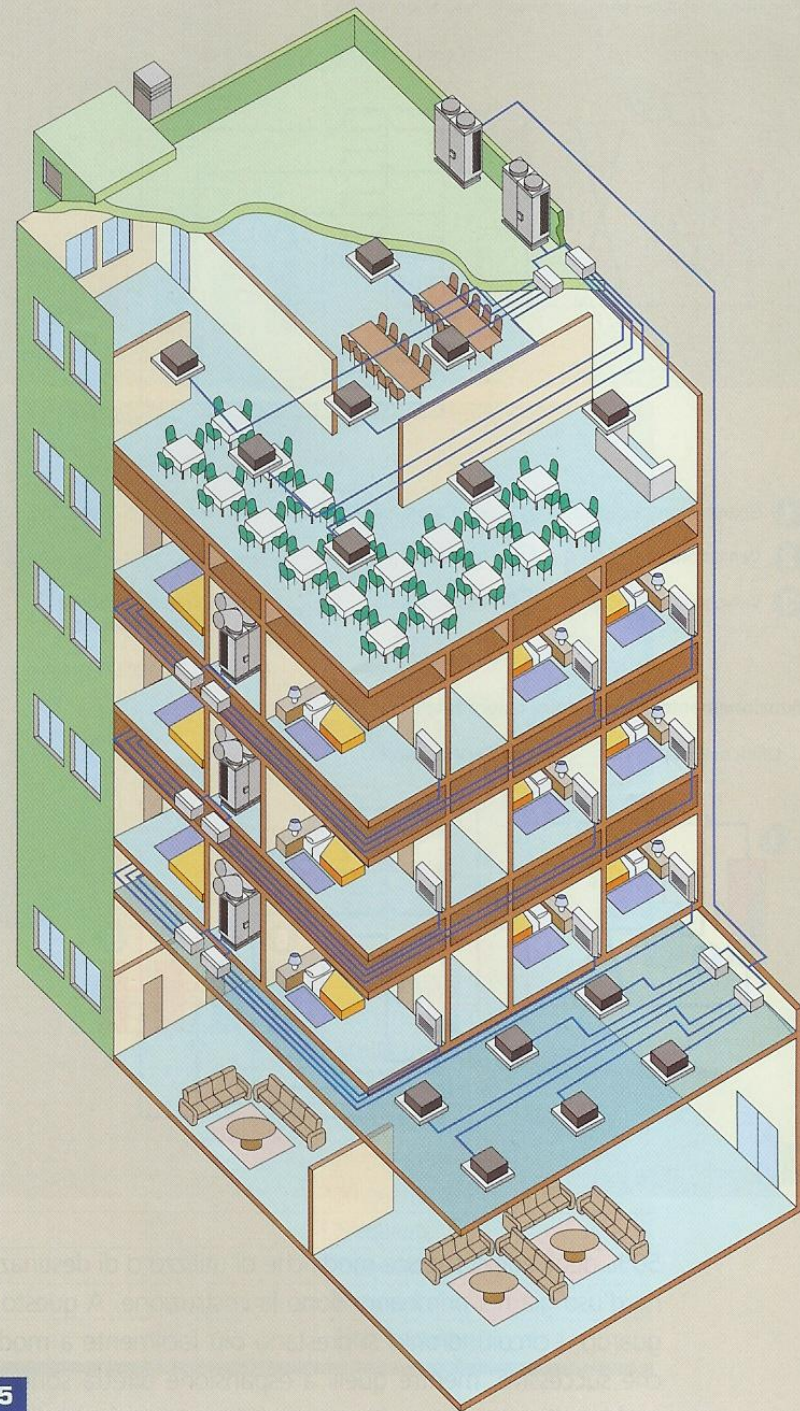

5

WATER AND AIR-WATER BASED SYSTEMS

Heating operation

In the past the heating systems have been designed and they were supposed to operate at high temperature, due to the use of combustion boilers.

Hence the usual temperature in the '70ies was 90°C or even vapour or high pressure hot water.

In the '90ies the condensing boilers were introduced reducing the water temperature at 60°C or even less.

The increase use of radiant systems and of the heat pumps has also lead to further reduction of the water temperature in the building

Usual temperatures in heating systems

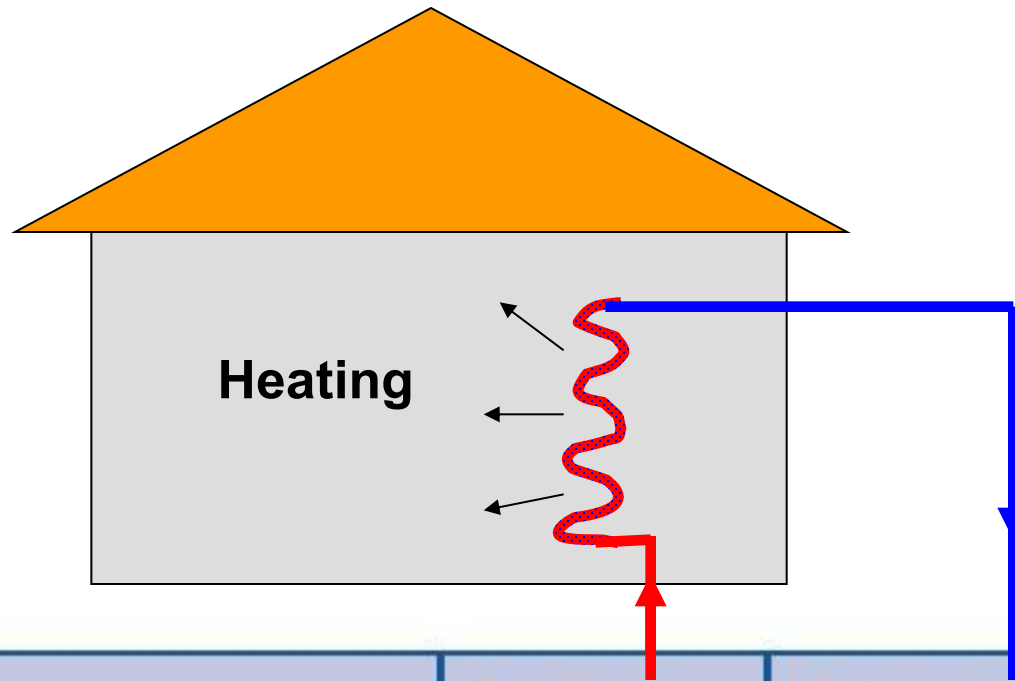

System	Supply flow	Return flow
High temperatures (HT)	90 °C	70 °C
Medium temperatures (MT)	55 °C	35 – 40 °C
Low temperatures (LT)	45 °C	25 – 35 °C
Very low temperatures (VLT)	35 °C	25 °C

Table 1. Definition of temperature ranges for heating designs

Effectiveness coefficient in heating

It is a qualitative parameter which is not useful for sizing the systems, but it is interesting to show the qualitative efficiency for heating solutions:

$$\Phi = \frac{t_{\text{supply}} - t_{\text{return}}}{t_{\text{supply}} - t_i}$$

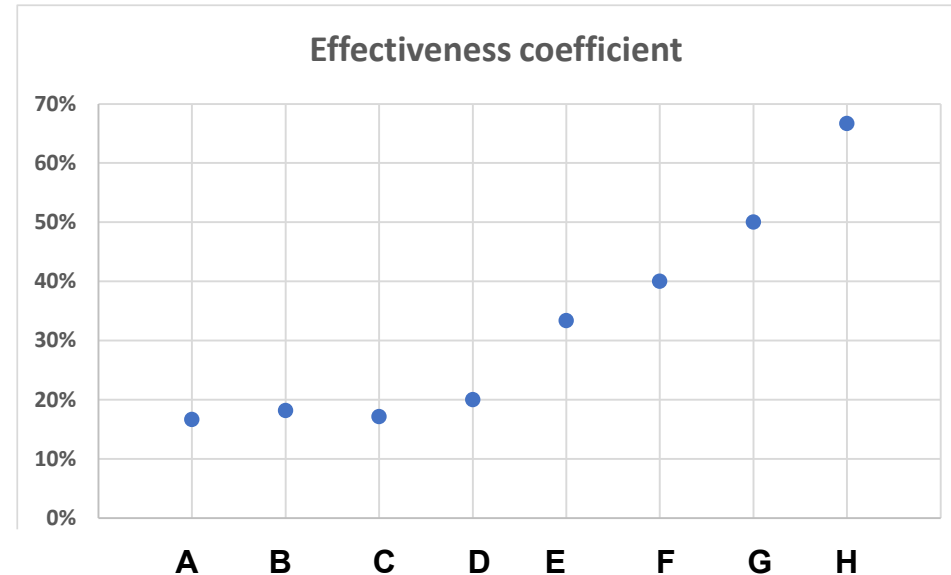

		Supply Temp.	Return Temp.	Effectiveness coefficient
A	High temperature radiators (70ies)	80	70	17%
B	Mid temperature radiators (90ies)	75	65	18%
C	Low temperature radiators (today)	55	49	17%
D	Fan-coil	45	40	20%
E	Chilled beams	35	30	33%
F	Radiant systems (90ies)	35	29	40%
G	Radiant systems (2000)	30	25	50%
H	Radiant systems (today)	26	22	67%

Temperatures in cooling

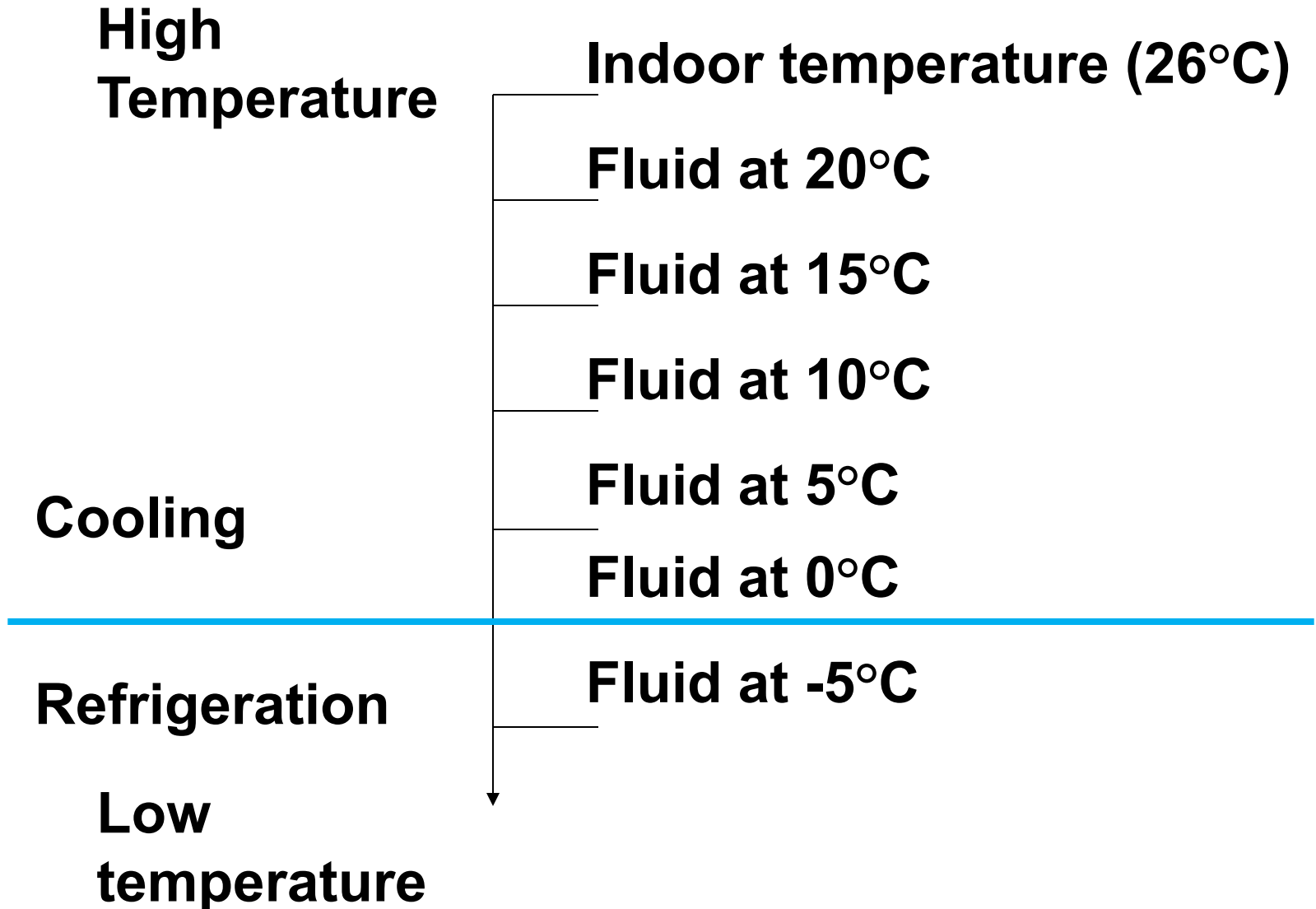

Effectiveness coefficient in cooling

		Supply Temp.	Return Temp.	Effectiveness coefficient
A	Fan coils	7	12	26%
B	All air/dehumidification	7	12	26%
C	Fan beams	15	18	27%
D	Radiant ceiling	17	20	33%
E	Radiant floor	19	21	29%
F	TABS	19	22	43%

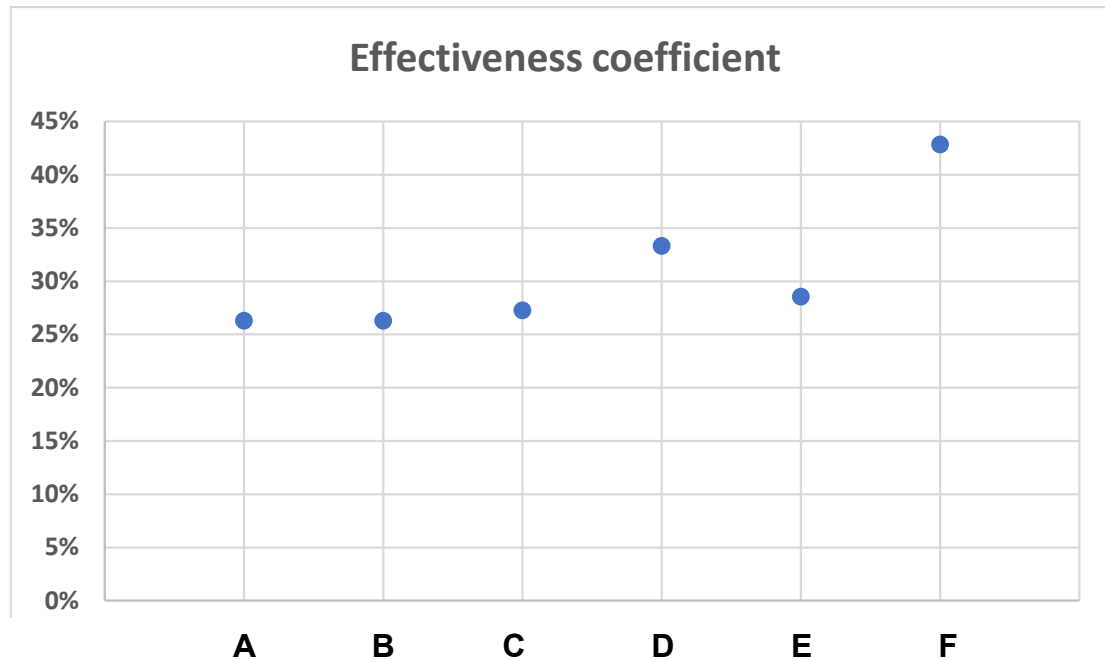

Hydronic terminal units

- *Radiators*
- *Finned coils/baseboard*
- *Convactor heating system*
- *Fan-coils*
- *Active beams / chilled beams*
- *Unit heaters*
- *Radiant systems*