

DISTRIBUTION SYSTEM AIR DIFFUSION IN ROOMS

Michele De Carli

*Department of Industrial Engineering
Università di Padova*

DUCTS

Sistemi di aggancio/ ancoraggio dei condotti *Hooking systems*

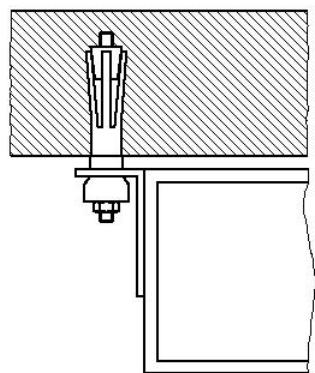

Suspended rectangular duct with expansion plug

Suspended circular duct with metallic strap and expansion plug

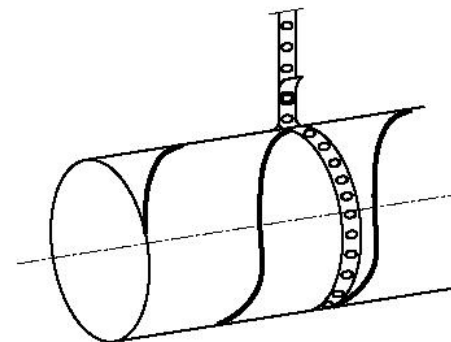

Giunzioni tra canali

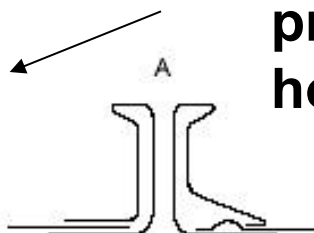
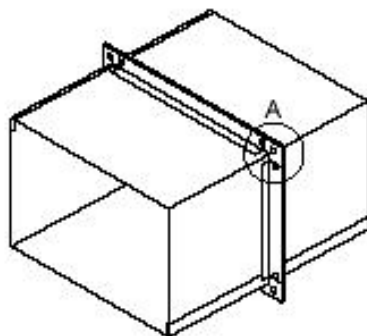

Slide-on cleats to press the flanges (bolt holes in the corners)

Byonett mount

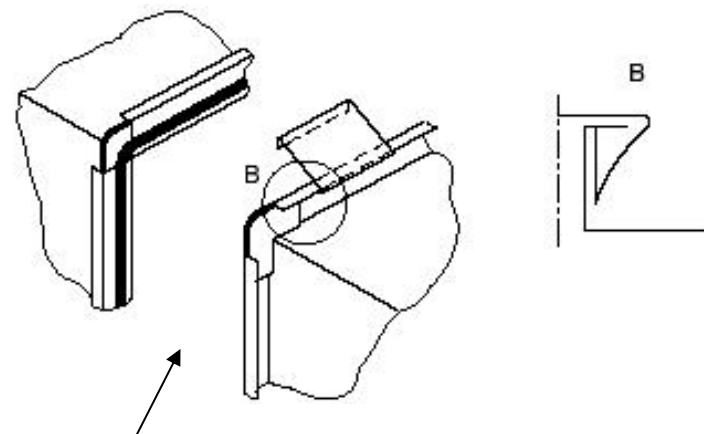
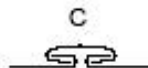
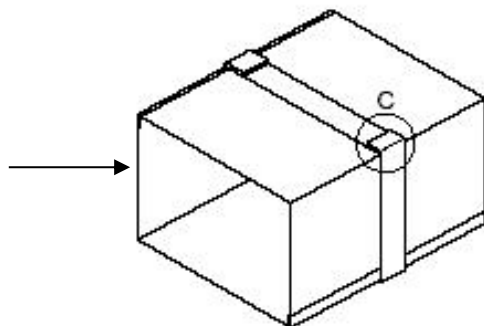

Reinforced flange

Rectangular ducts

METAL DUCTS

The metal ducts present good properties. They can be insulated and they present reinforcements in order to limit the vibrations which could lead to noise generation (see pictures below).

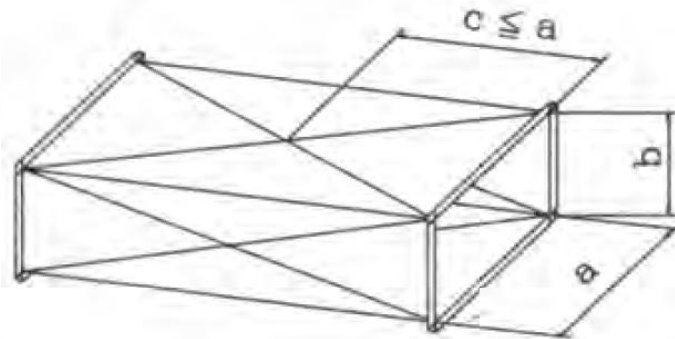
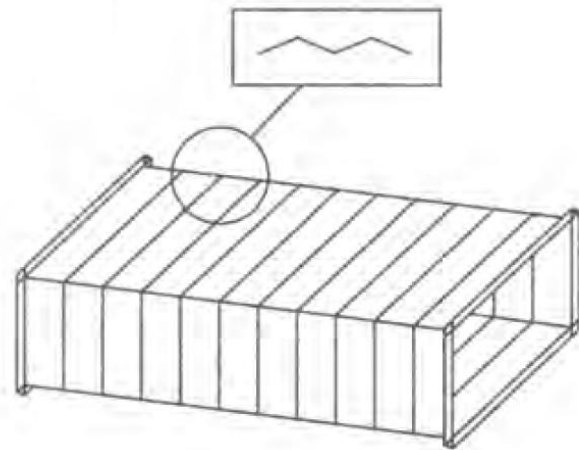

Transverse stiffened duct

Cross-creased duct

They resist to high pressure difference between flowing air and outside environment, but they are heavy.

PREINSULATED DUCTS

An increasing diffuse duct system is the pre-insulated aluminium duct, with polyurethane foam within two aluminium foils.

Pros: light, insulated, easy to handle and install.

Cons: pressure limits inside the ducts

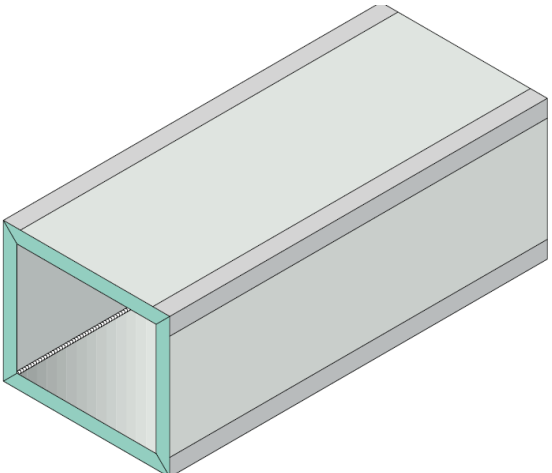
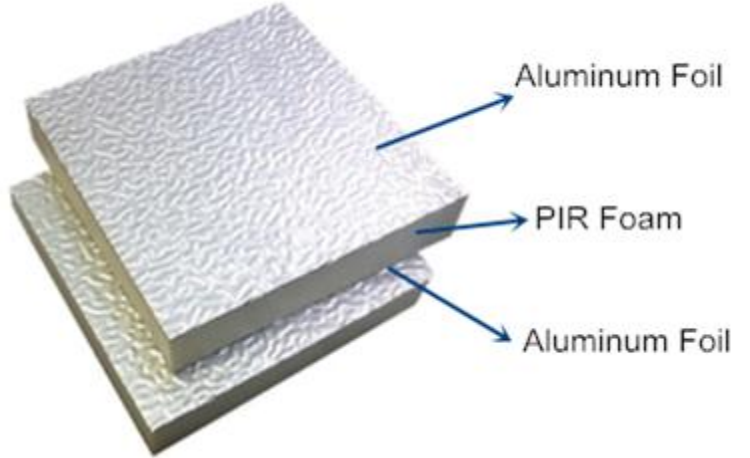

base and height lower than 1160 mm

A sum of 4 sides lower than or equal to 1040mm

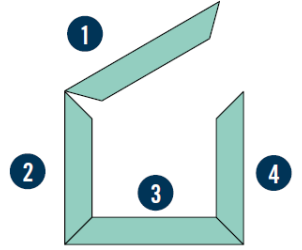
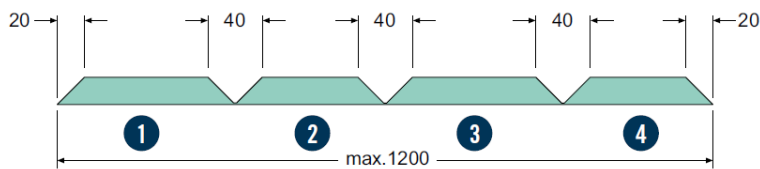

When the sum of the sides making up the duct is lower than 1040 mm it is possible to construct one duct on one single panel

Equalizing dampers

Rectangular in aluminium

Rectangular in steel

Iris dampers

Butterfly/blade damper

Butterfly/blade damper

Slide damper

Electrical engine/actuator

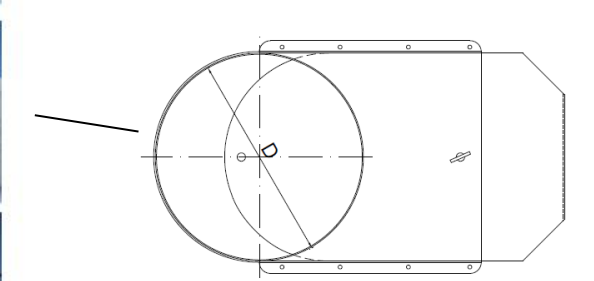
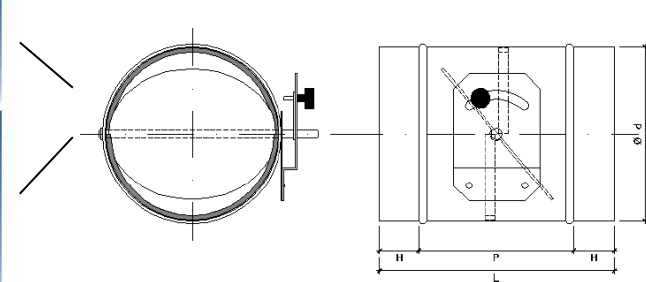
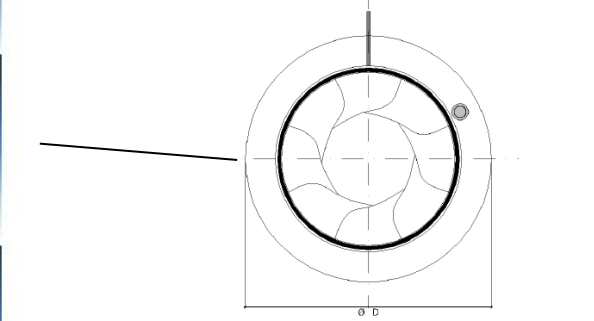
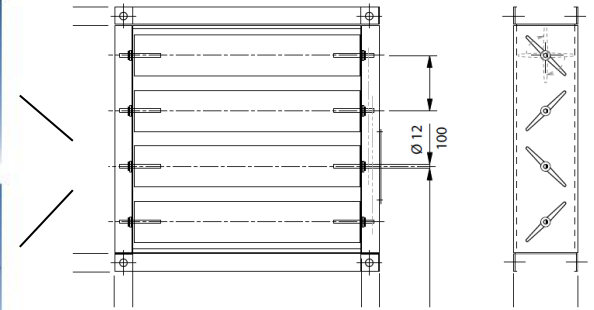
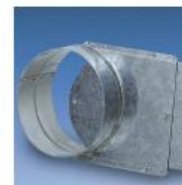
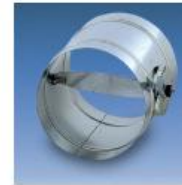
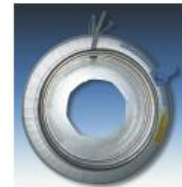

Air diffusers

Ceiling swirl diffusers

Round ceiling



Round ceiling



Round ceiling



Round ceiling



Round supply diffuser



Squared ceiling

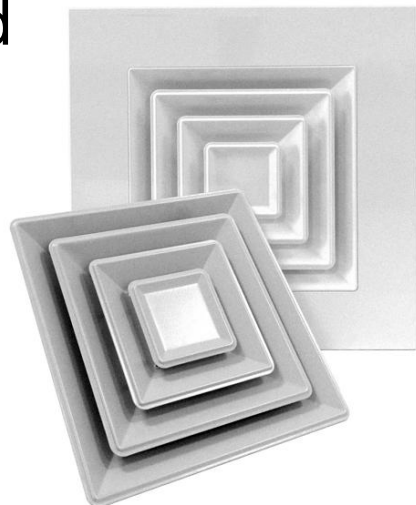

Linear and slot diffusers



The ideal installation location for a linear diffuser is a continuous wall to wall installation.

Slot diffuser is suitable for ceiling sidewall installation.



With cylinders



Louver / Vent



Grill



Jet nozzle diffusers

Installation for large buildings

Low height installation



duct diffuser with adjustable nozzle

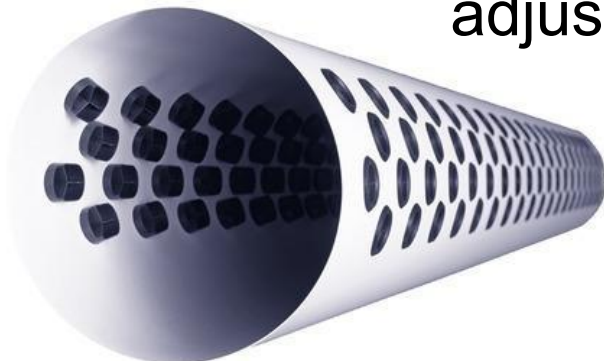

Textile ducts



Plenum

Element with an increase of section in order to transform dynamic pressure into static pressure

To distribute the air in different ducts



To balance the pressure before the air diffuser

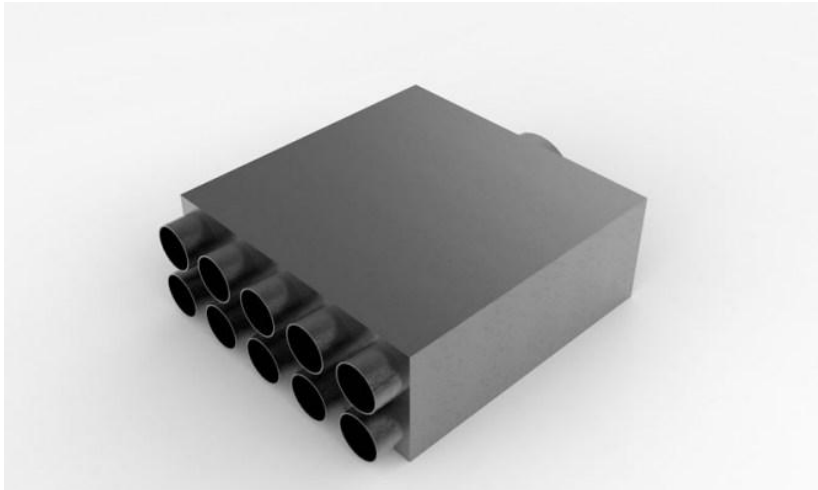

Silencers

They are installed on the supply and the return of the main ducts close to the AHU



Rectangular silencers



For circular ducts

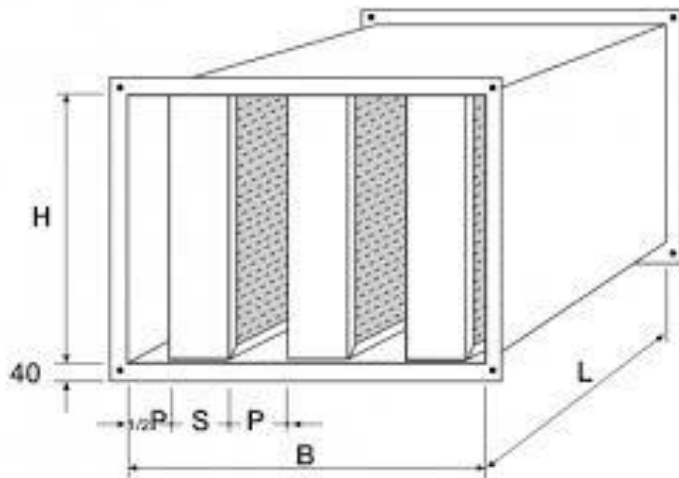

The choice has to be done as a function of the space between baffles and length

Fire dampers

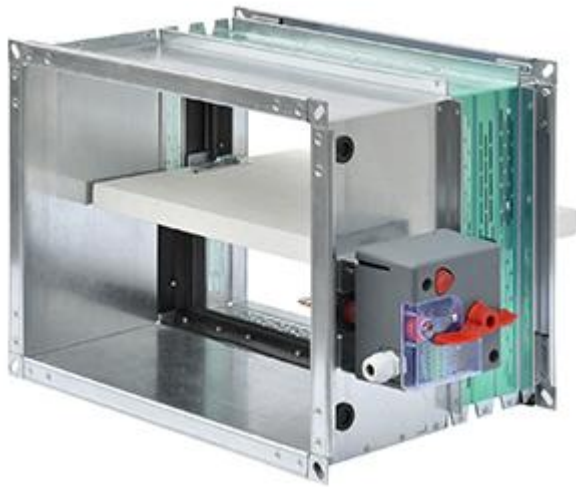

The fire dampers have to be tight, to resist to heat, smoke and have to achieve insulation between the two separated environments once closed. Usually they refer to the time that they can resist to the fire solicitation

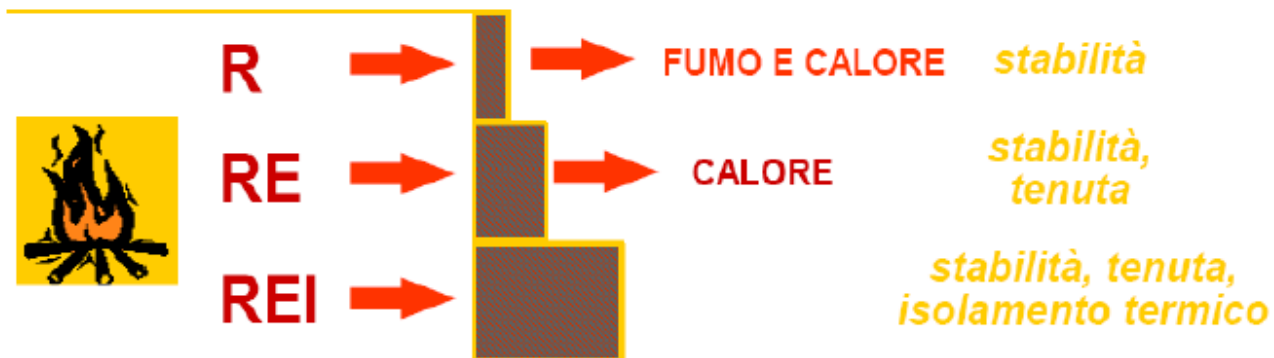

Partitioning means to guarantee the same fire resistance of the structure, where there is a duct crossing the structures

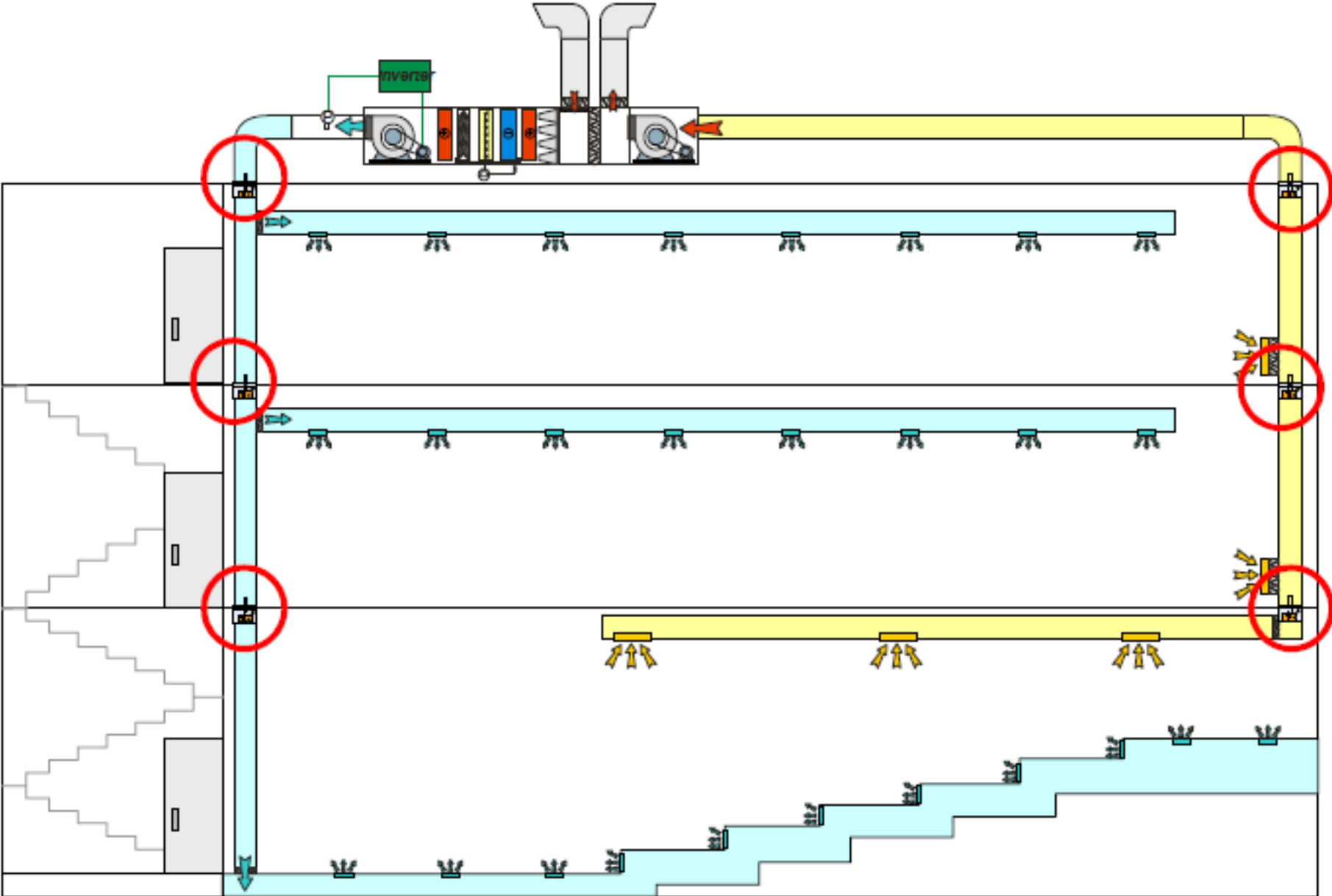

MIXING VENTILATION

This is the reference method for ventilating the indoor environments, as it represents the most common type of ventilation. The air enters the room via one or more inlet with quite high momentum so as to put in motion the room air, leading to high turbulence, thus obtaining a good mixing.

In this ventilation system the air enters on the top of the room (from the ceiling or from the upper part of the walls).

Usually return air grills are put in the lower part of the room.

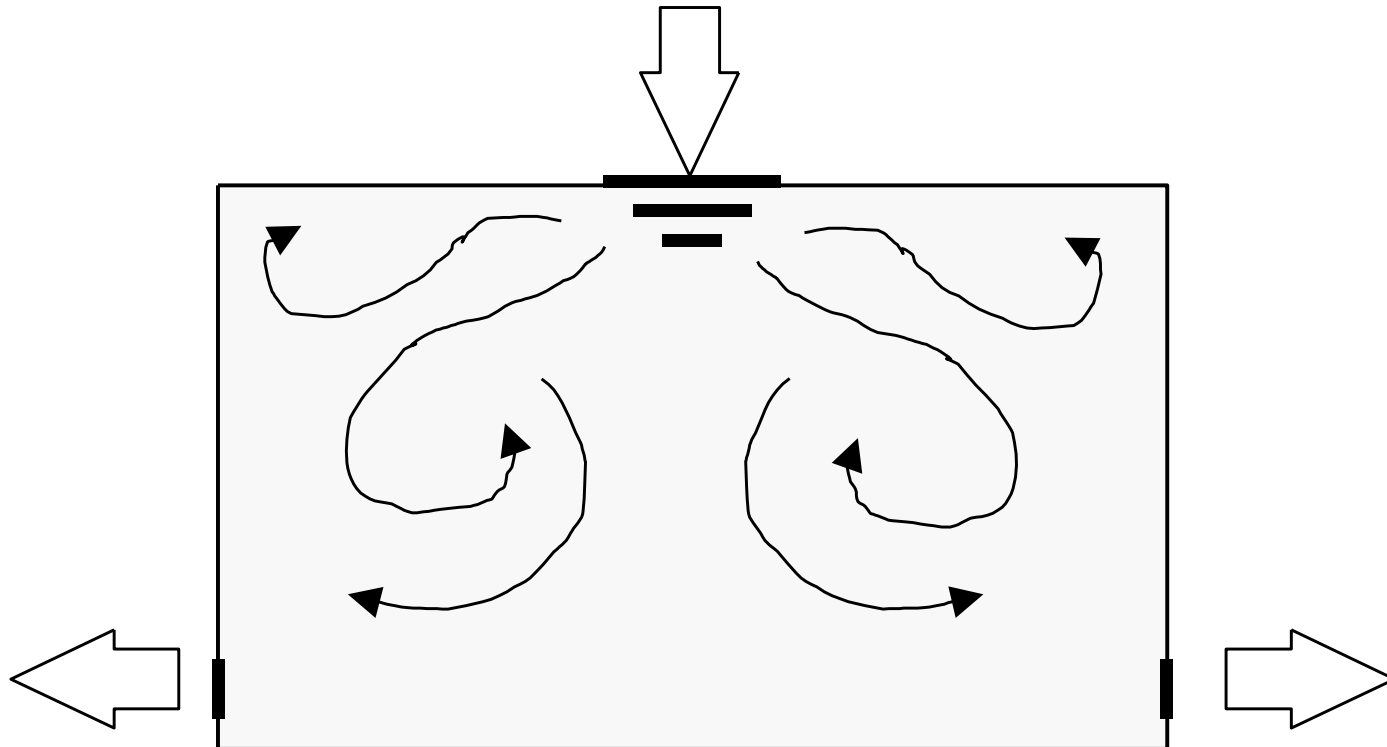

MAIN PARAMETERS FOR THE VENTILATION

Inlet velocity v_i Maximum velocity in the entering section.

Air throw L Let's consider first an isothermal air stream (horizontal distribution). The widening of the air stream (and as a consequence the increasing mixing with the air room) tends to increase the area of the jet stream, diminishing at the same time the velocity of the air.

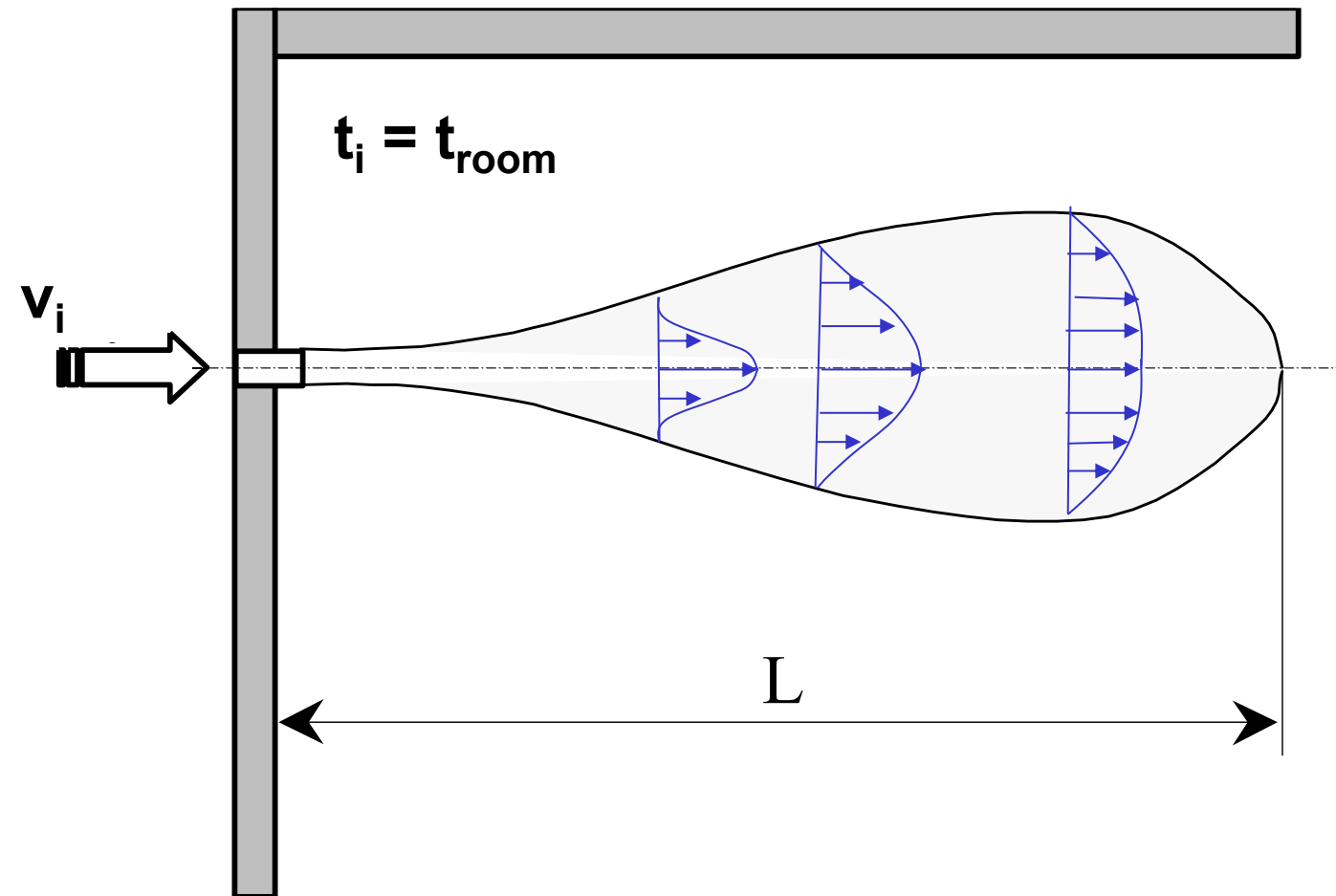

The AIR THROW is defined as the distance along the jet axis from the inlet to the section where the velocity has diminished down to the limit velocity v_{lim} . Usually this value is supposed to avoid local discomfort (DR) and hence the $v_{lim} = 0.15 \div 0.25$ m/s in the occupied zone.

Induction effect

In a ventilation context, induction refers to the effect caused when a high-speed jet of air passes stagnant air. That jet of air drags with it the ambient air, mixes with it and increases in volume.

The momentum of the supply inlet air q_i drags the surrounding room air, hence the overall flow rate q_{tot} (supplied jet air + dragged room air) will be greater than q_i . The induction ratio i can be defined as:

$$i = \frac{q_{tot}}{q_i}$$

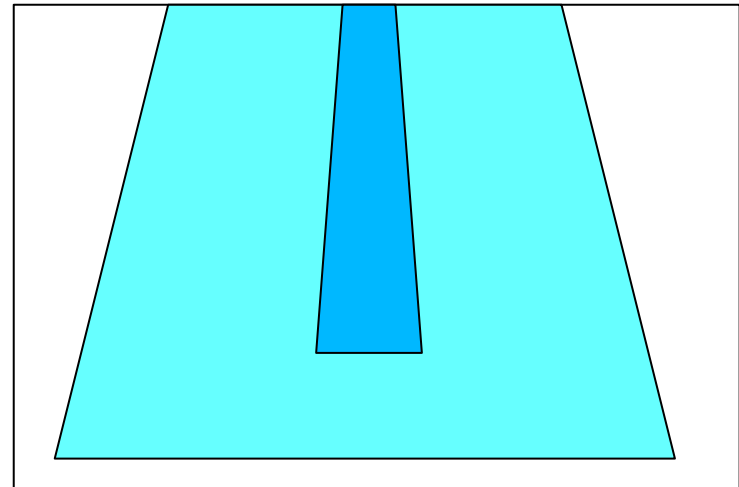
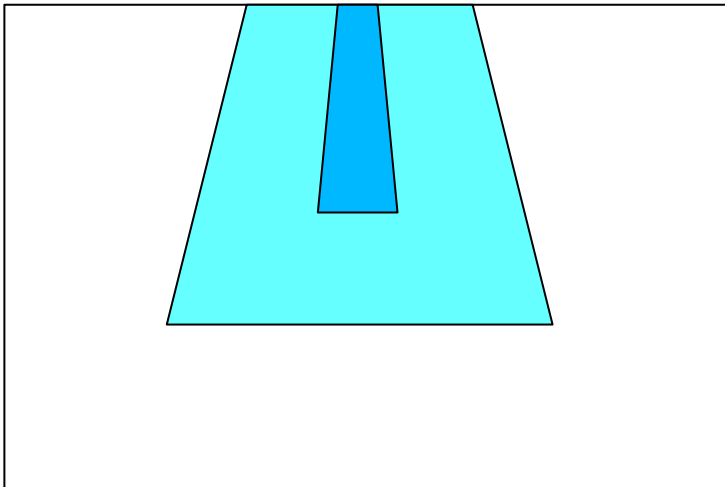
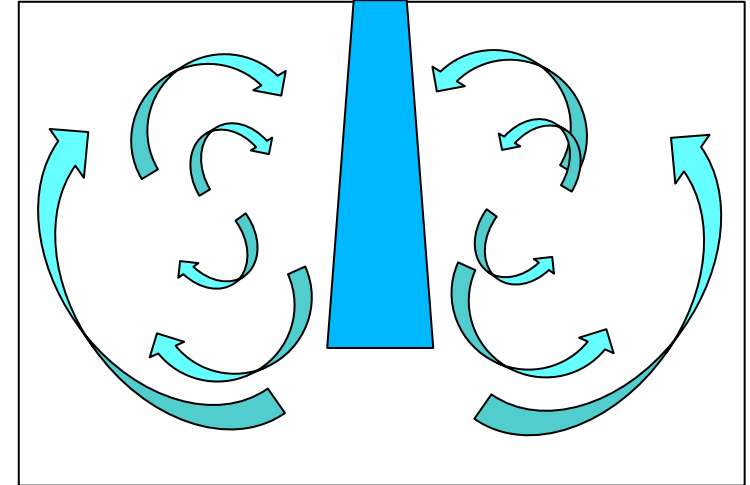

Low induction jet (low induction ratio) High induction jet (high induction ratio)

Air drop, buoyancy

When there is a temperature difference between air jet and room air the jet flow is not straight but it bends due to the temperature difference and hence to the density difference:

- Upwards when $t_i - t_{\text{room}} > 0$
- Downwards when $t_i - t_{\text{room}} < 0$

The distance between the centre of of the air inlet and the core of the corresponding to the jet throw is named buoyancy and air drop. This height is relevant for the sizing of the air inlets.

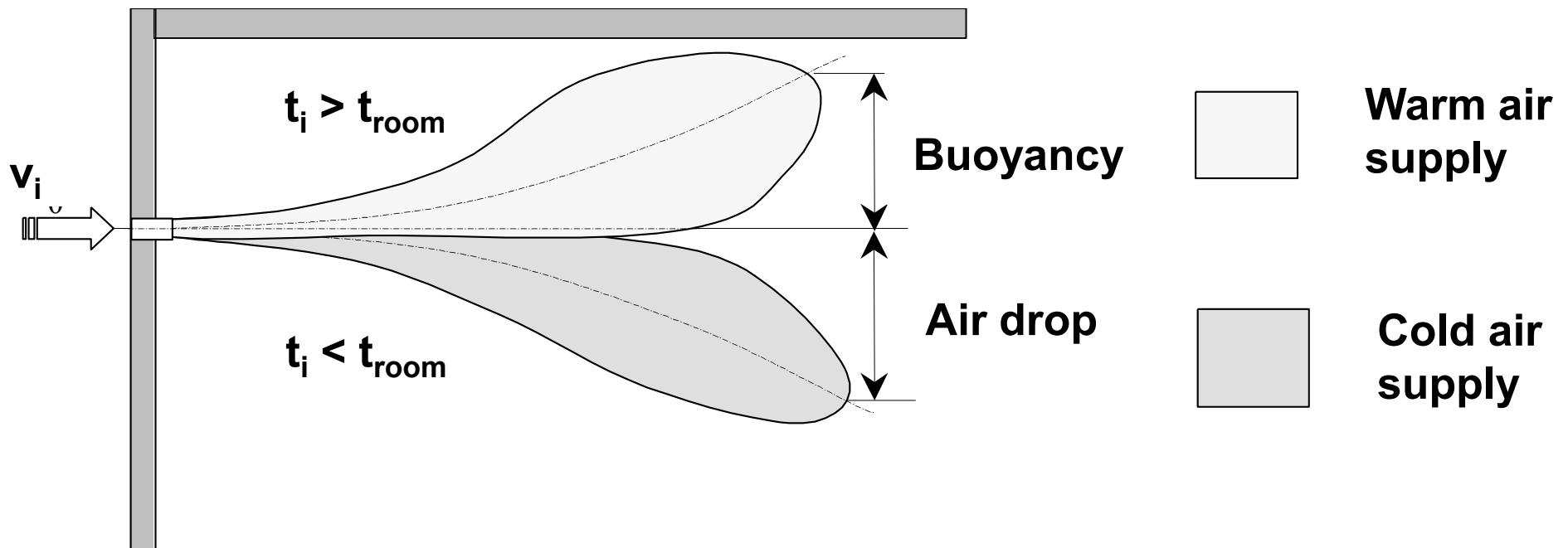

Coanda effect

Coanda effect is the phenomenon in which a jet flow attaches itself to a nearby surface and remains attached even when the surface curves away from the initial jet direction.

In free surroundings, a jet of fluid entrains and mixes with its surroundings as it flows away from a nozzle (as explained 3 slides back).

When a surface is brought close to the jet, this restricts the entrainment in that region. As flow accelerates to try balance the momentum transfer, a pressure difference across the jet results and the jet is deflected closer to the surface - eventually attaching to it. In doing so, the rate at which the jet mixes is often significantly increased compared with that of an equivalent free jet.

Usually this effect is used in ventilation inlet on the ceiling and by placing the inlet in lateral position at a distance of < 30 cm from the ceiling.

This way the jet enters more in depth and it is possible to drag more air than in free conditions. The result is hence to have greater jet throw and less drop

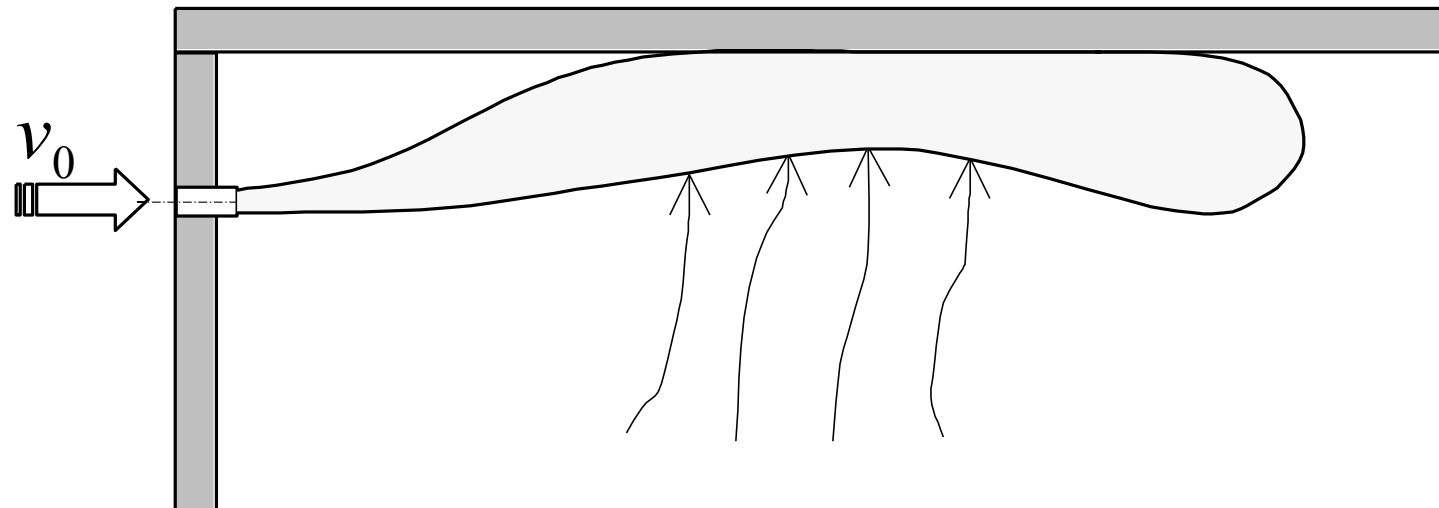

Mixing ventilation and short cut

The ventilation system is "short cut" when the make up air is withdrawn from the room before it has been in the people operating zones.

A "short cut" will reduce the efficiency of the ventilation system, has no mission, and is in general avoided.

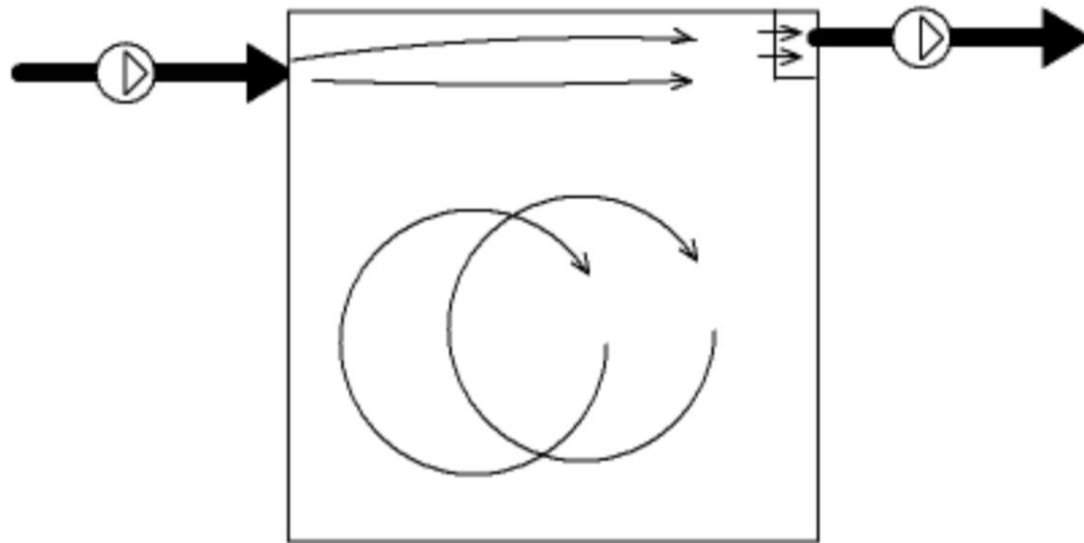

The Engineering ToolBox

Possible strategies:

PISTON VENTILATION

In a ventilation system based on the piston principle the supply air moves through the rooms like a "piston".

The piston principle presents a minimum turbulence of the air flow passing through the room.

It is used in special applications - like clean rooms, operating theaters, intensive cares, post-transplants, pharmaceutical industry, electronic industry, laboratories etc.

To keep the flow "laminar" and stable the air velocity through the room should not be below 0.25 m/s, which requires relatively large volume flows and large inlets.

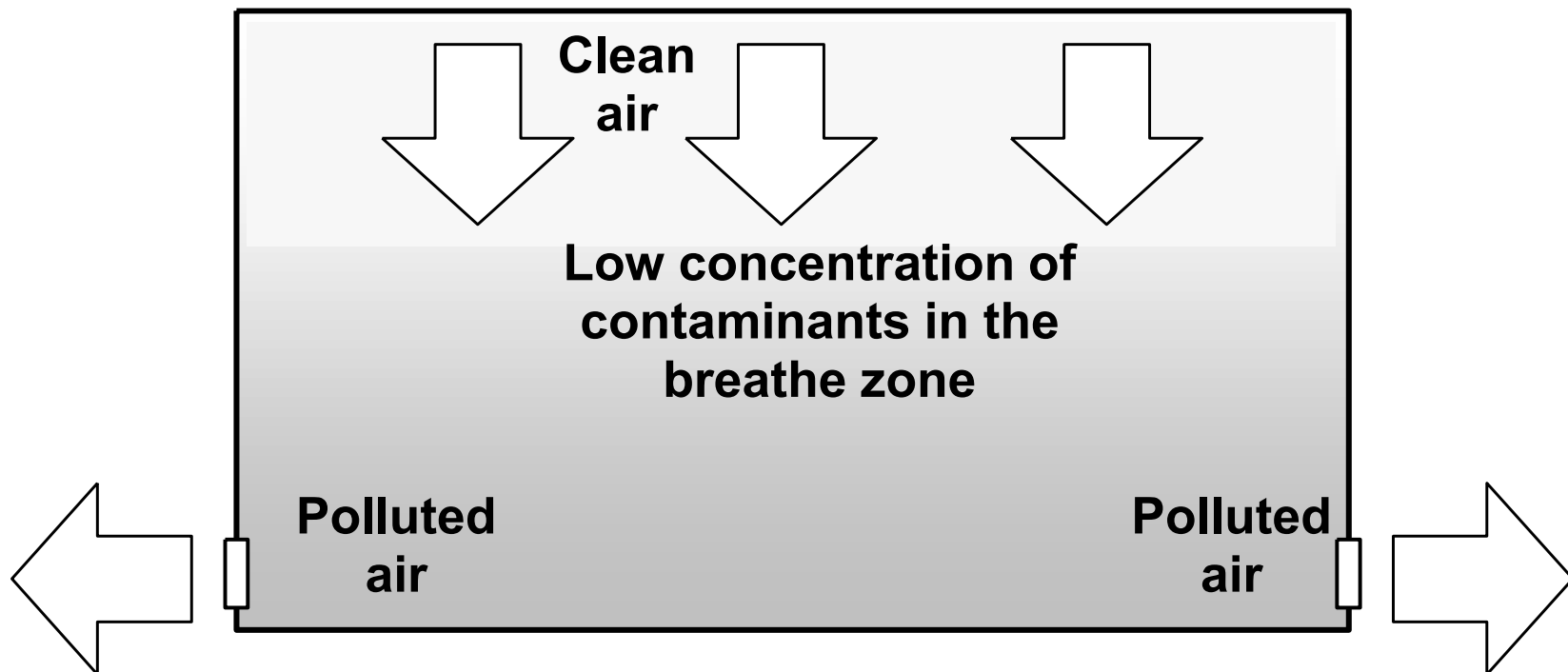

DISPLACEMENT VENTILATION

The Principle of displacement ventilation:

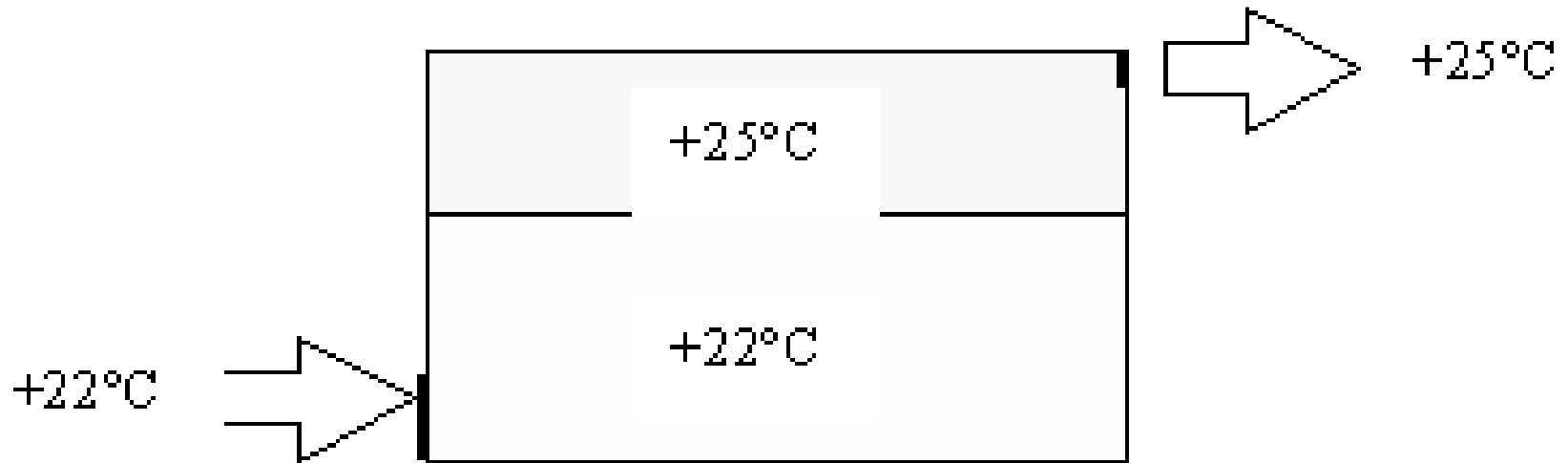

With the displacement principle heat and pollution is transferred from the residence zone close to the floor - to the ceiling where it is evacuated through the outlet system.

Make up air is supplied with low velocity very close to the floor. The supply air is normally colder than the average air in the residence zone. The evacuated air close to the ceiling is warmer than the average air in the residence zone.

Hence there is a stratification of temperature and of contaminants, which are the two goals of the displacement ventilation.

By so doing, the air quality in the occupied zone is generally superior to that achieved with mixing ventilation.

Mechanisms of displacement ventilation:

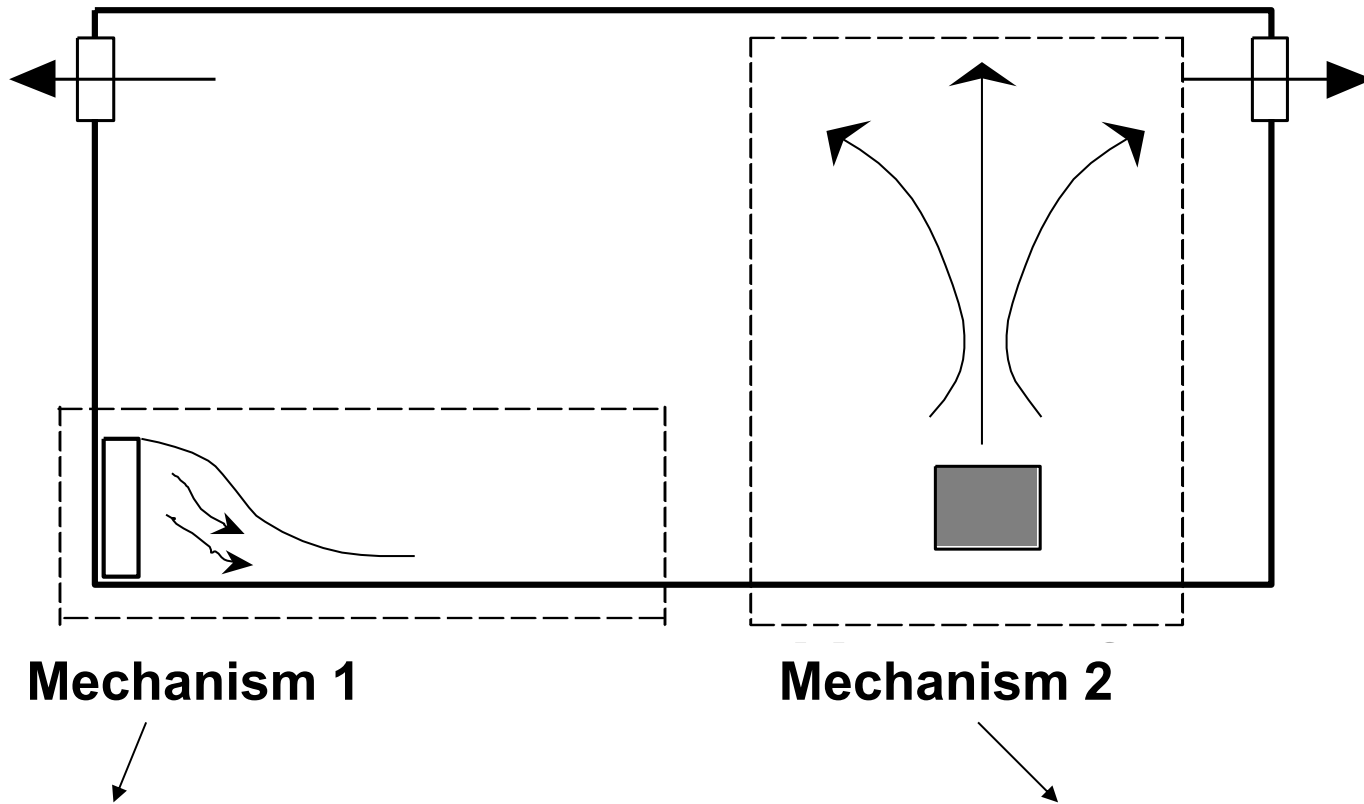

Mechanism 1

Mechanism 2

Air is introduced into the space at low velocities, which causes minimal induction and mixing. Displacement outlets may be located almost anywhere within the room, but have been traditionally located at or near floor level.

The system utilizes buoyancy forces in a room, generated by heat sources such as people, lighting, computers, electrical equipment, etc., to remove contaminants and heat from the occupied zone.

Mechanism 1: inlet air in the room

$$T_0 < T_a$$

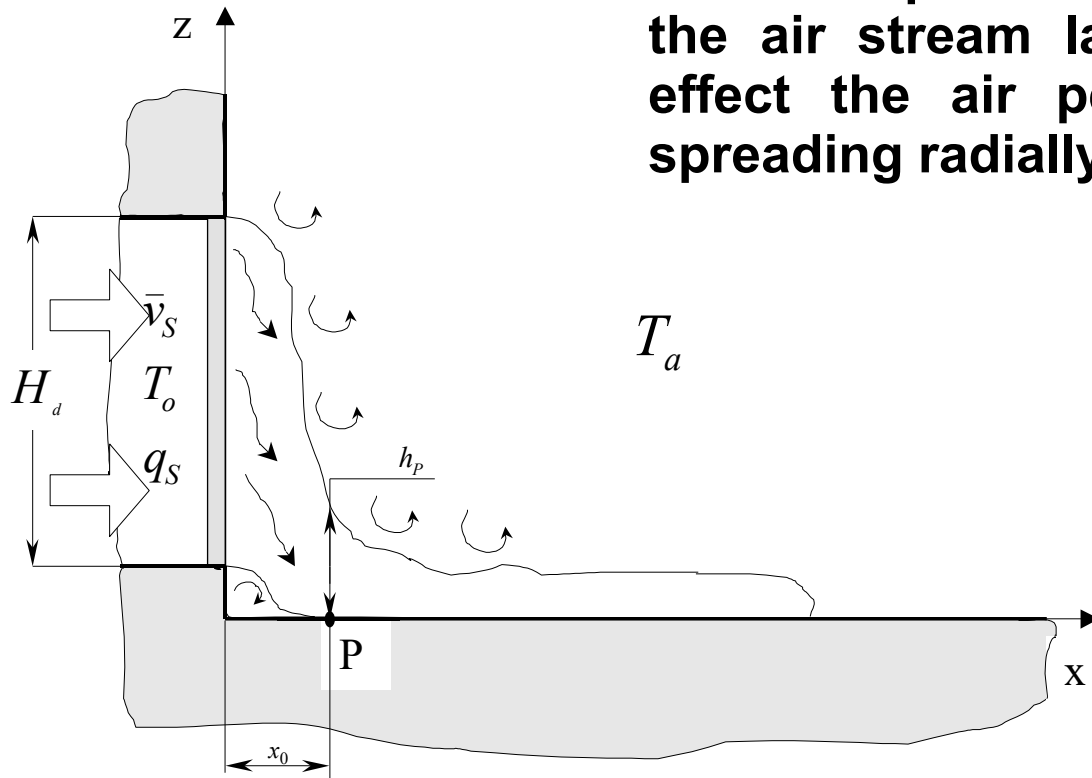

Air enters in the lower part of the room and at slightly lower temperature ($T_0 < T_a$). Due to the lower density the air stream lays down on the floor. By coanda effect the air penetrates in depth into the room spreading radially.

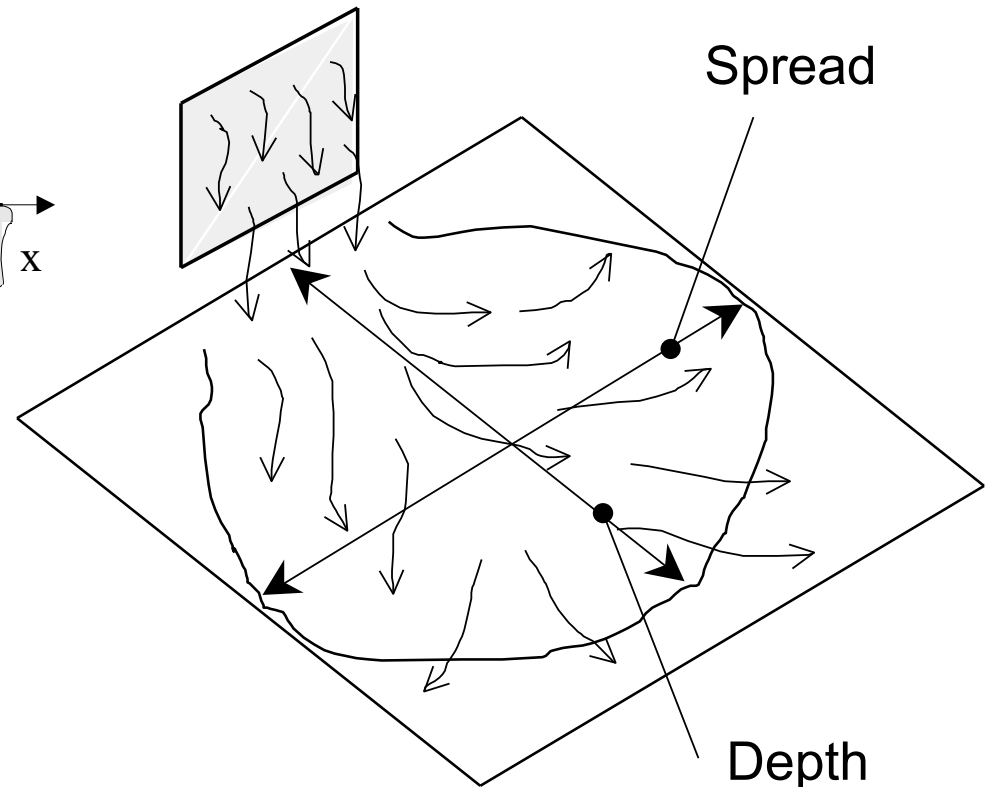

To avoid draft risk the air enters at very low velocity (0.2 m/s about). Hence the area of the outlets is greater than the vents of the mixing ventilation.

Mechanism 2: thermal plume

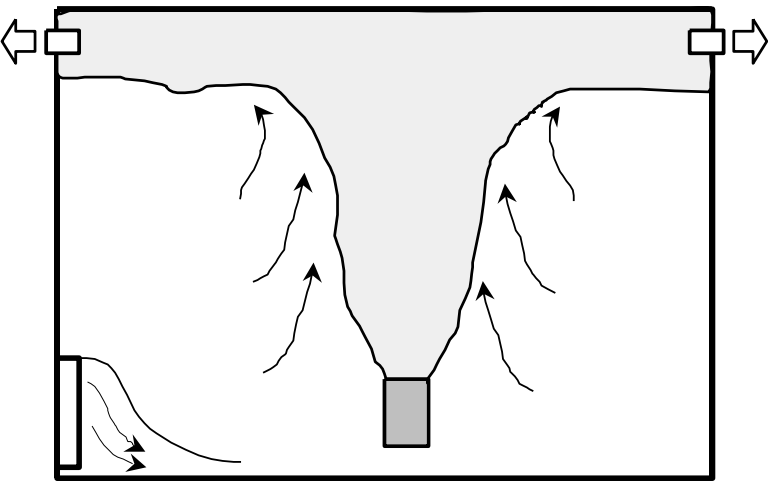

A thermal plume is a convection current caused by buoyancy forces that causes local air to warm and rise above the heat source, entraining surrounding air and increasing in size and volume as it loses momentum. The maximum height to which a plume will rise is dependent on the strength of the heat source, as the initial momentum of the plume will increase.

Also, a room with more stratification will reduce the relative density of the plume and, as a result, limit the height to which the plume will rise. The ceiling will stop the thermal plume. As a result there is an upper zone with high concentration of contaminants and high temperatures. The occupant zone will present lower pollutants concentration.

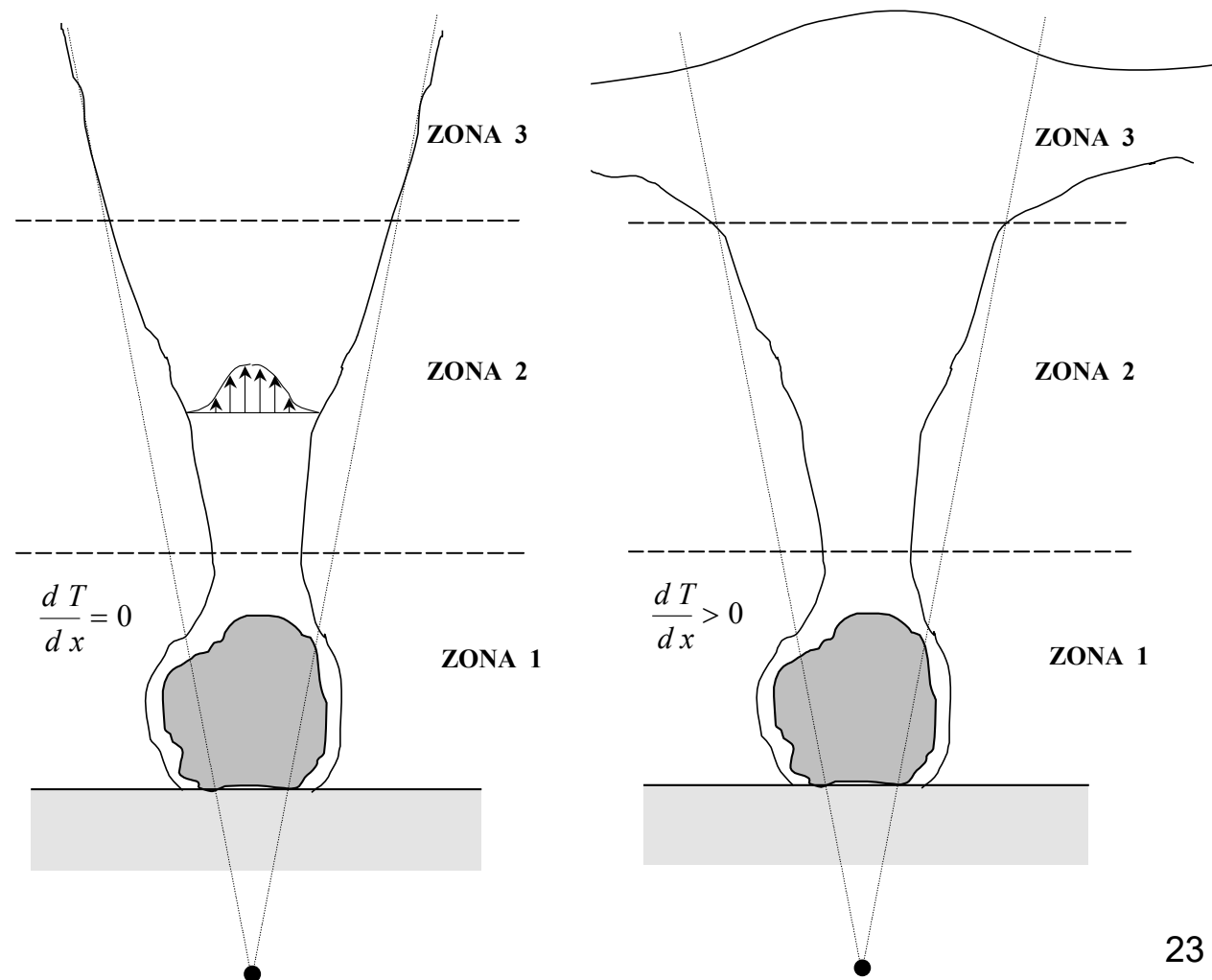

This means that in principle the IAQ in the breathing zone can be achieved and you may also reduce the air flow rate compared to mixing ventilation still with better IAQ in the breathing zone.

By decreasing the air flow rate the polluted upper zone will increase in volume lowering the so called height of the neutral zone z .

Heat (lights) supplied under the ceiling have limited influence on the temperatures in the room.

The cooling temperatures of the air supplies are limited to some degrees under the temperature in the residence zone.

The displacement ventilation system is suited for ventilation and cooling systems. The system is not suited for heating. In case of heating an additional water based system with low room air velocity is needed (radiant panels or even radiators).

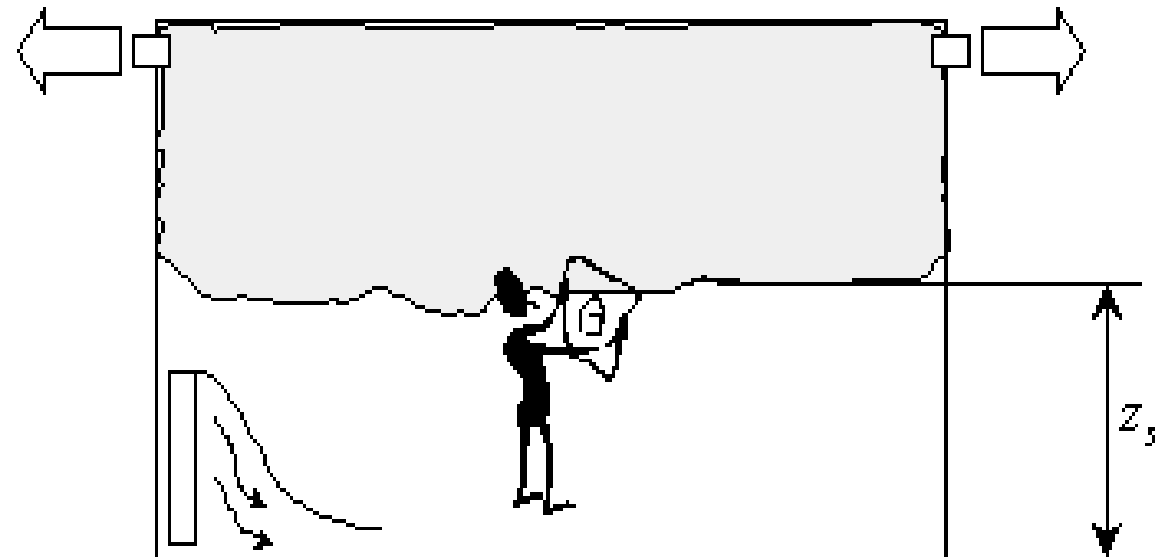
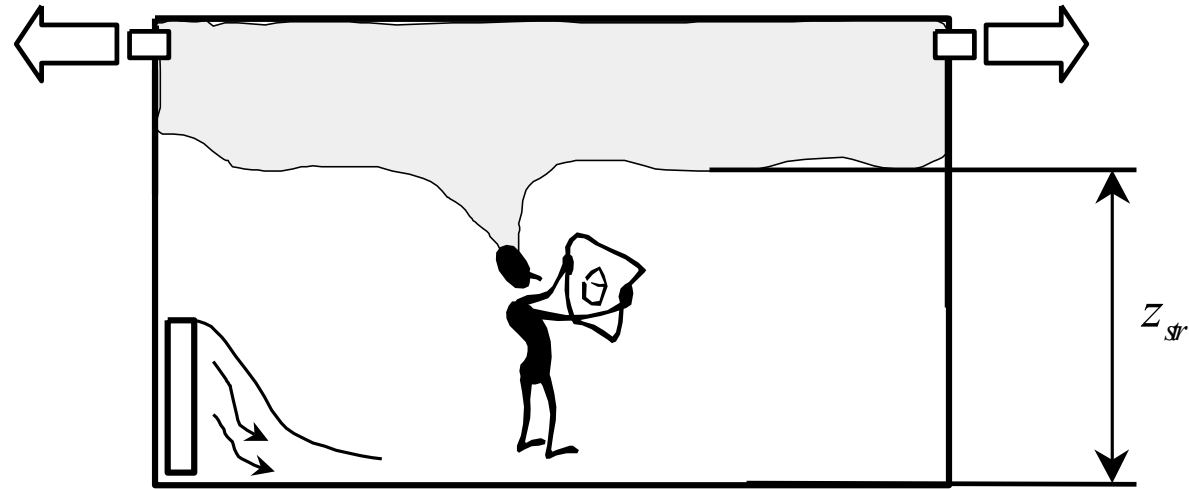

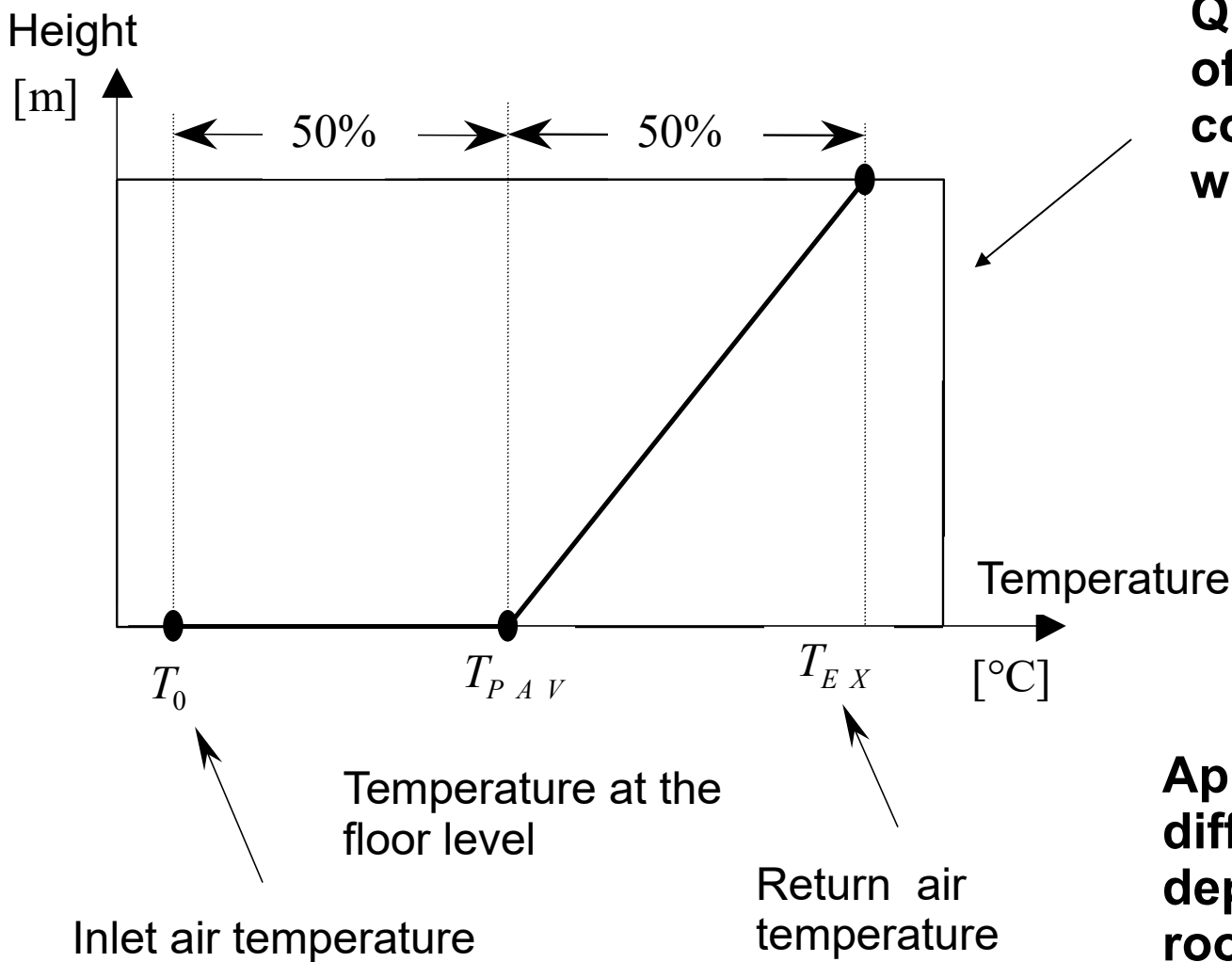

Qualitative simplified pattern of temperature and contaminant concentration with displacement ventilation.

Approximate temperature difference in height in rooms depending on the height of the room

The temperature difference between ankle and head (0.1 m – 1.1 m) for seated sedentary persons has to be considered as local discomfort parameter. With higher activity and standing person, less problems.

Height of the ceiling	Δt between inlet air and return air
< 3m	6 ÷ 8 °C
3 ÷ 6 m	8 ÷ 10 °C
6 ÷ 10 m	10 ÷ 12 °C

Air outlets for displacement ventilation

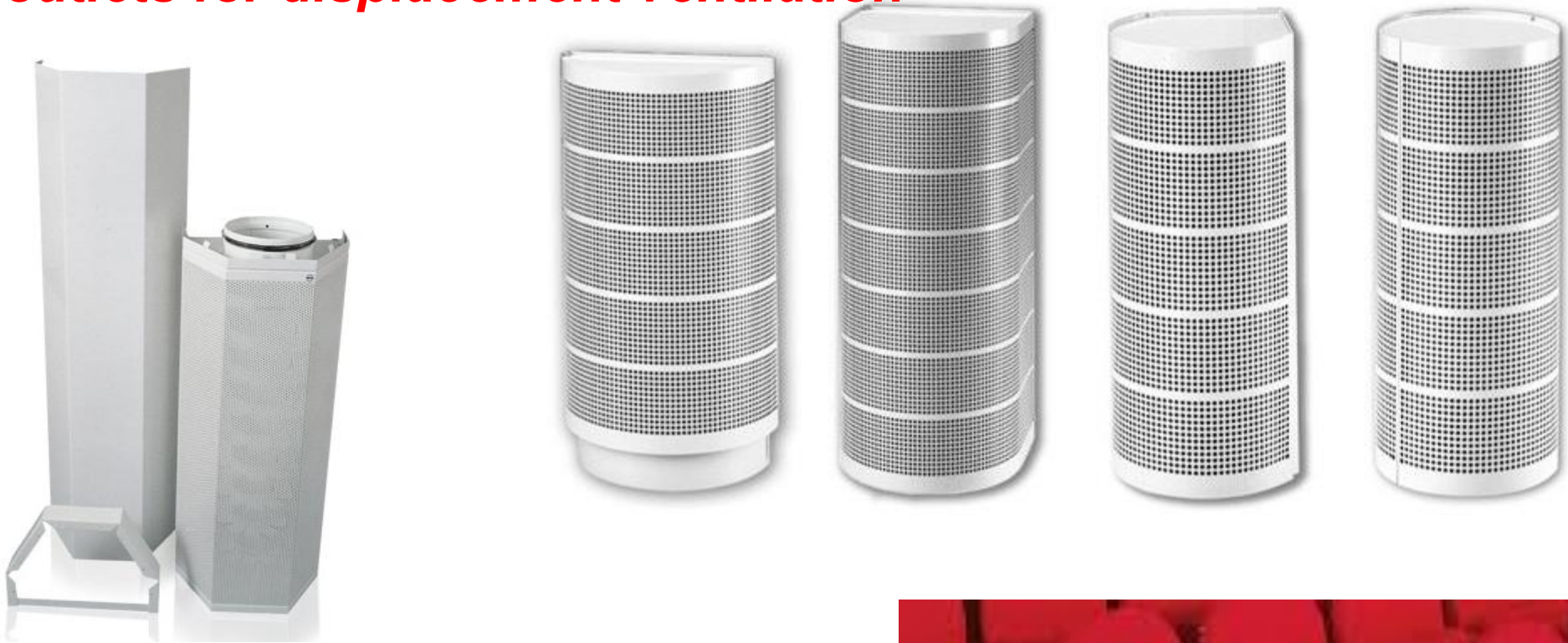

Advantages of displacement ventilation

- **Better IAQ with the same air flow rate**
- **Possibility to reduce the flow rate to get the same air quality or even better IAQ than mixing ventilation**
- **Internal loads will go out by means of the buoyancy effect and for cooling purposes these heat loads have not to be removed by the cooling system (cooling peak power reduction and cooling energy saving)**
- **It is a particular interesting technique for Lrge rooms and in rooms with relevant heights.**

Disadvantages of displacement ventilation

- **Critical conditions with time variable internal gains**
- **A change in the lay-out of the rooms can cause lack of ventilation air in some zones**

UNDERFLOOR AIR DISTRIBUTION (UFAD)

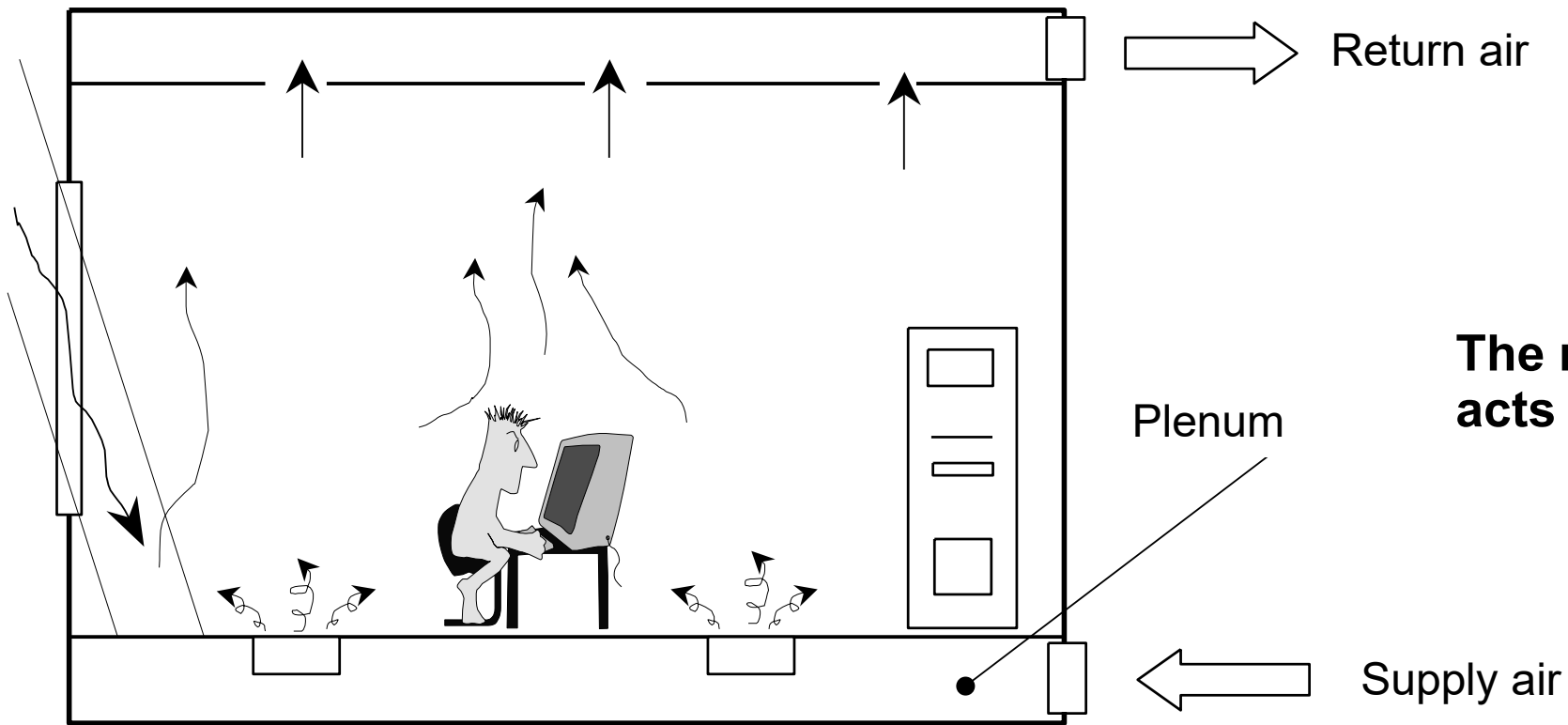

The raised floor acts as a plenum



Maintenance of the air ducts

Openings for maintenance in suspended ceilings (shafts), minimum sizing for the access.

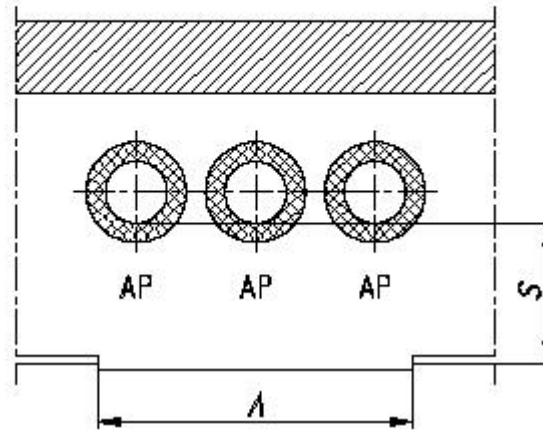
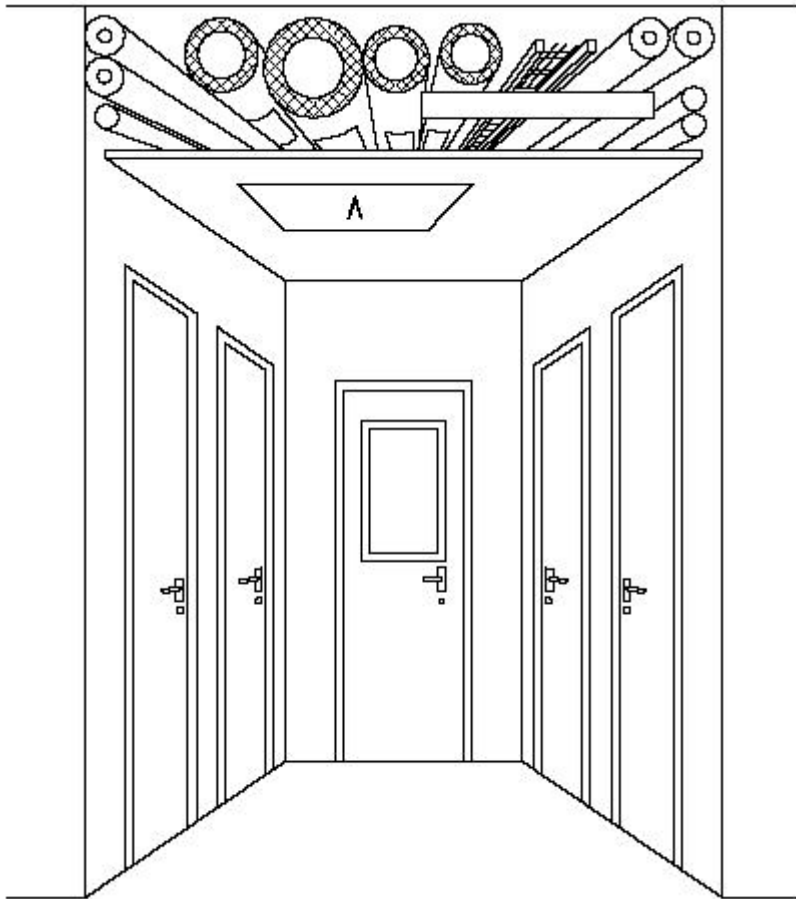

S mm	A ^{**)} mm
da 0 a 200	200 × 300
> 200 ≤ 500	250 × 350
> 500	600 × 600

^{**)} O, almeno, la dimensione della botola di accesso.

Cleaning

Contact Vacuum Method

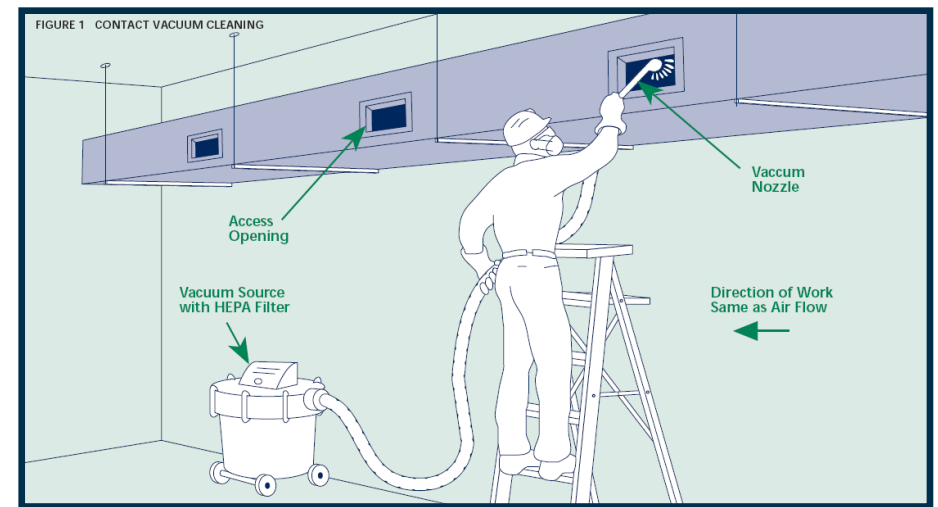

Hand Brushing

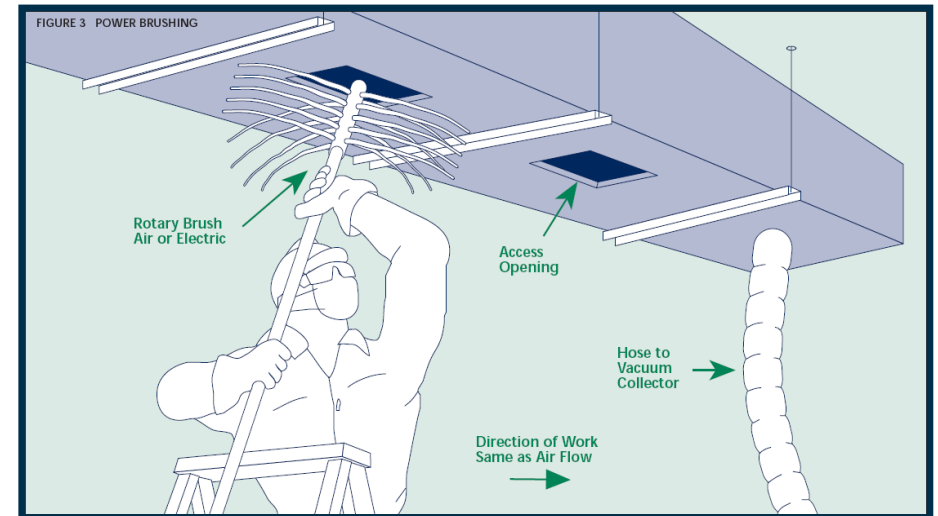

Air Sweep Method

