

FULL AIR SYSTEMS

FULL AIR SYSTEMS

PROS

Good possibility to control indoor conditions

Complete absence of piping etc.

Localization in a unique Air Handling Unit (AHU) the main components of the plant

Easy installation of heat recovery units

CONS

Poor energy efficiency

Size of air ducts

Need of accurate balancing of air ducts

BALANCE OF A ROOM

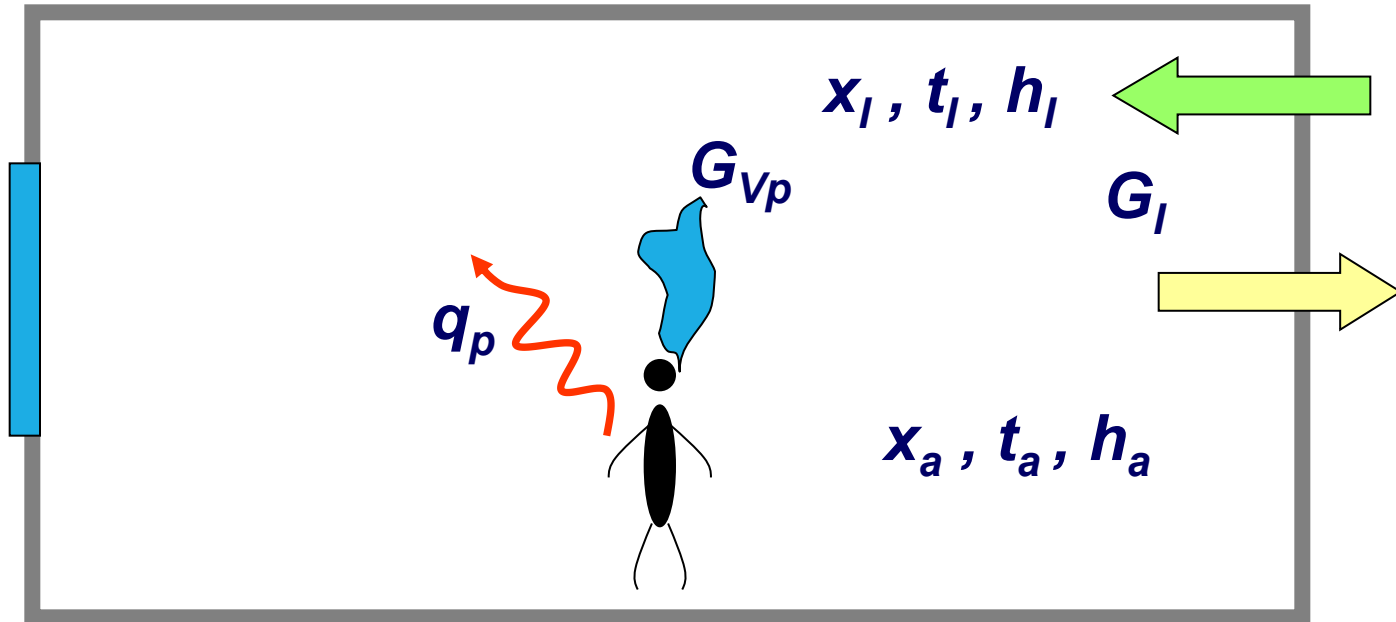

THERMAL AND VAPOUR BALANCE OF A ROOM

$$q_p = G_I c_p (t_a - t_I) \quad (1)$$

$$G_{vp} = G_I (x_a - x_I) \quad (2)$$

$$q_p + r G_{vp} = G_I (h_a - h_I) \quad (3)$$

$$\frac{(3)}{(2)} \rightarrow \frac{q_{tp}}{G_{vp}} = \frac{h_a - h_I}{x_a - x_I}$$

$$\frac{(1)}{(3)} \rightarrow = \frac{q_p}{q_{pt}} = \frac{c_p (t_a - t_I)}{h_a - h_I}$$

WINTER

FACOLTA' DI INGEGNERIA DELL'UNIVERSITA' DI PADOVA

ISTITUTO DI FISICA TECNICA

DIAGRAMMA PSICROMETRICO

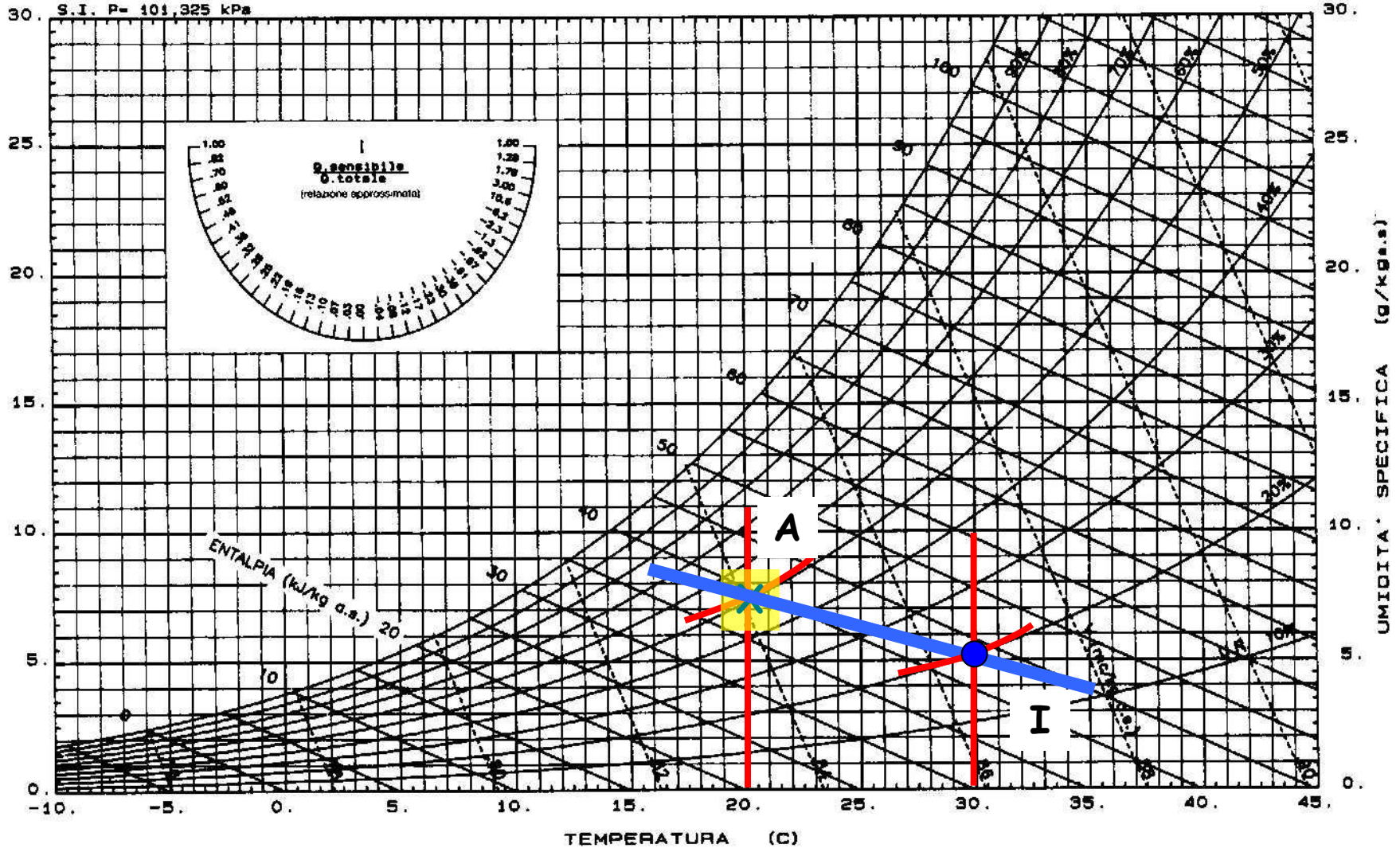

The greater the distance from *I* and *A* the lower the air flow rate



LOW CAP-EX

Lower flow rate → IAQ ?

$$t_I - t_a = 15 \div 25 \text{ } ^\circ\text{C} \quad \text{in} \quad \text{HEATING}$$

$$t_a - t_I = 10 \div 12 \text{ } ^\circ\text{C} \quad \text{in} \quad \text{COOLING}$$

IN THESE PLANTS:

✓ if $G_{a,fresh} < G_I$ \longrightarrow $G_{recirculation} = G_I - G_{a,fresh}$

✓ se $G_{a,fresh} > G_I$ \longrightarrow Just fresh air $G_I = G_{a,fresh}$

In a plant the design conditions occur rarely

Conditions change over the time

Different zones may require different loads

(living room/bedrooms, South-North, West-East, etc.)

SINGLE DUCT

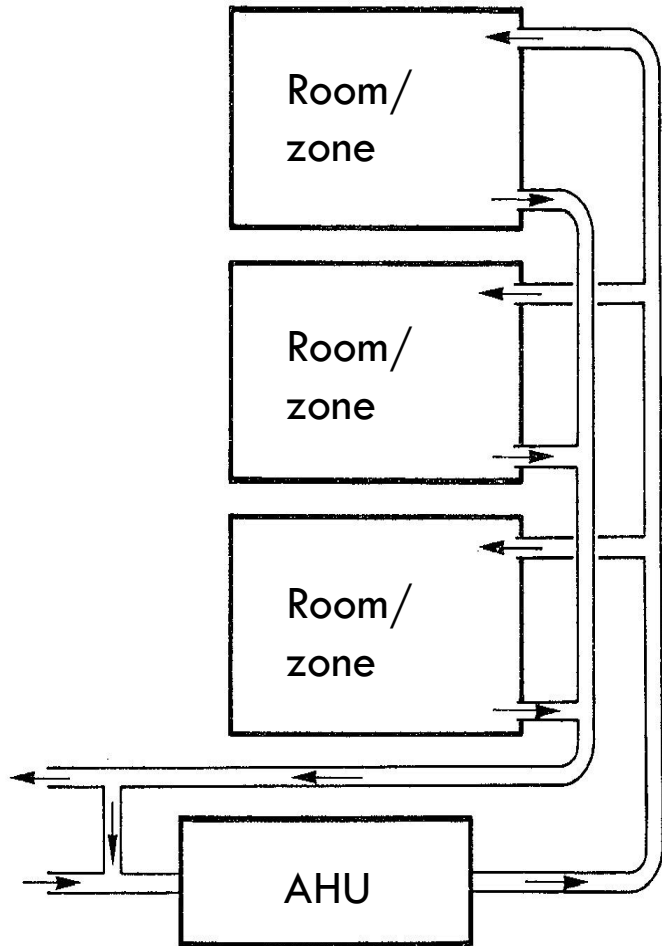

- *A single duct connects the AHU to the rooms/zones*
- *The air flow rate may be different from zone to zone, but the inlet conditions are the same (temperature and relative humidity)*
- *Same straight line for each room/zone*
- *The set of the rooms supplied by a single duct represent the same climatic zone*

SCHEME OF AN AHU

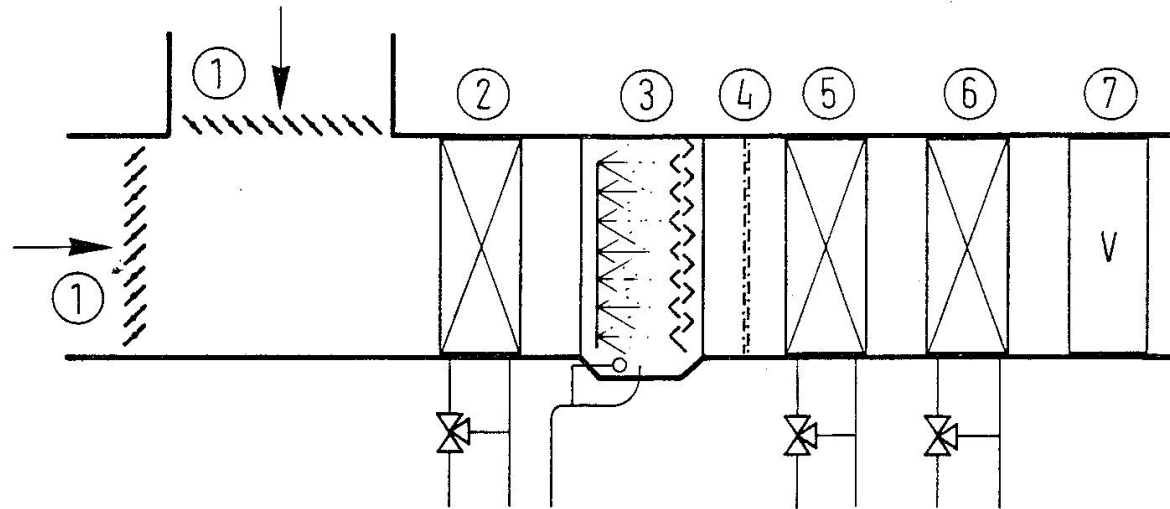

1. Equalizing dampers
2. Pre-heating coil
3. Atomizing humidifier
4. Droplet separator
5. Cooling coil
6. Reheat coil
7. Fan

AHU:

HEATING OPERATION

The pre-heat coil determines the inlet humidity ratio in the room.

The reheat coil has the goal to control t_{IMM}

COOLING OPERATION

The cooling coil varies the inlet humidity ratio.

The reheat coil controls the inlet temperature

Winter with heat recovery (70%), steam humidifier

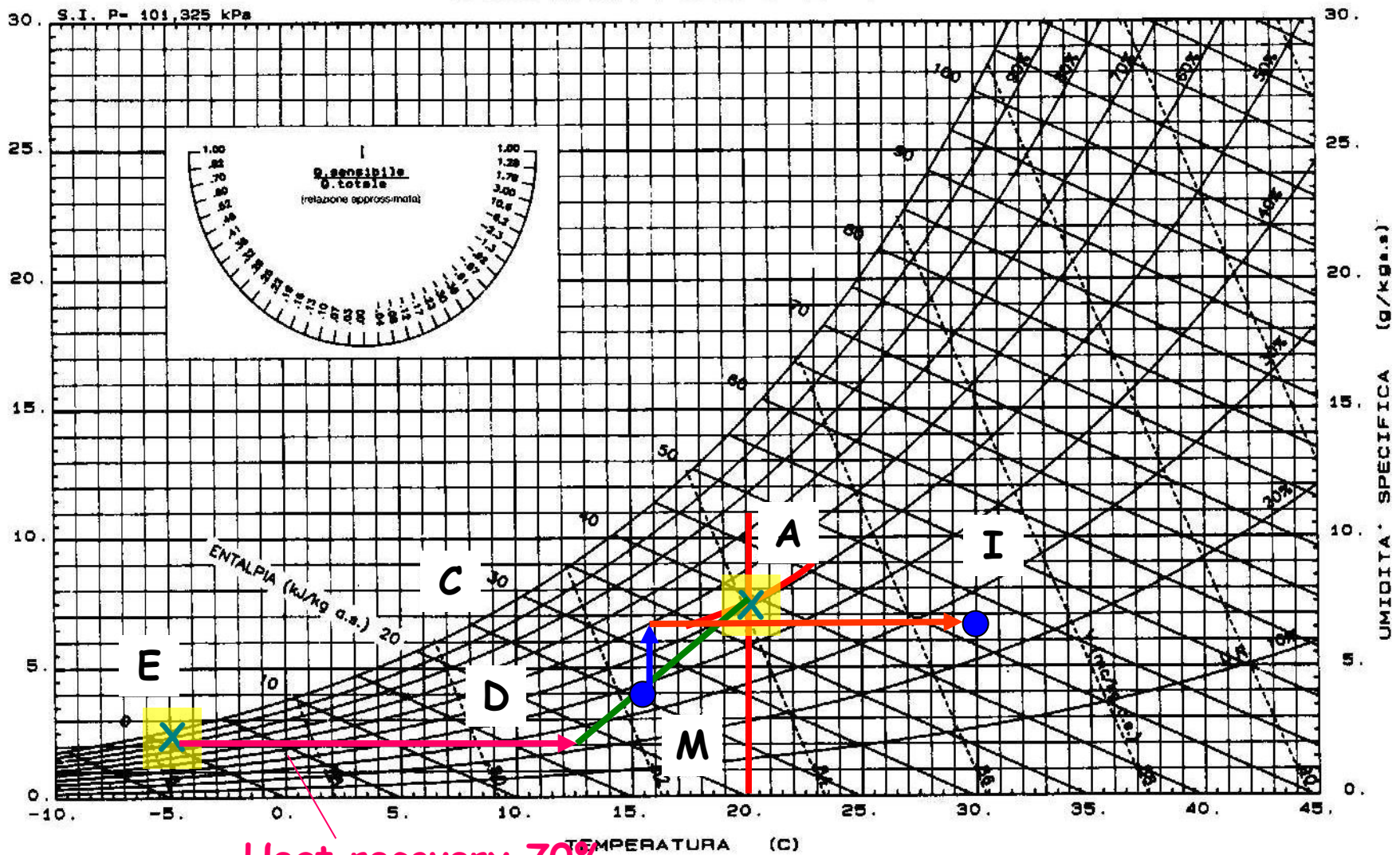

Heat recovery 70%

Summer no heat recovery

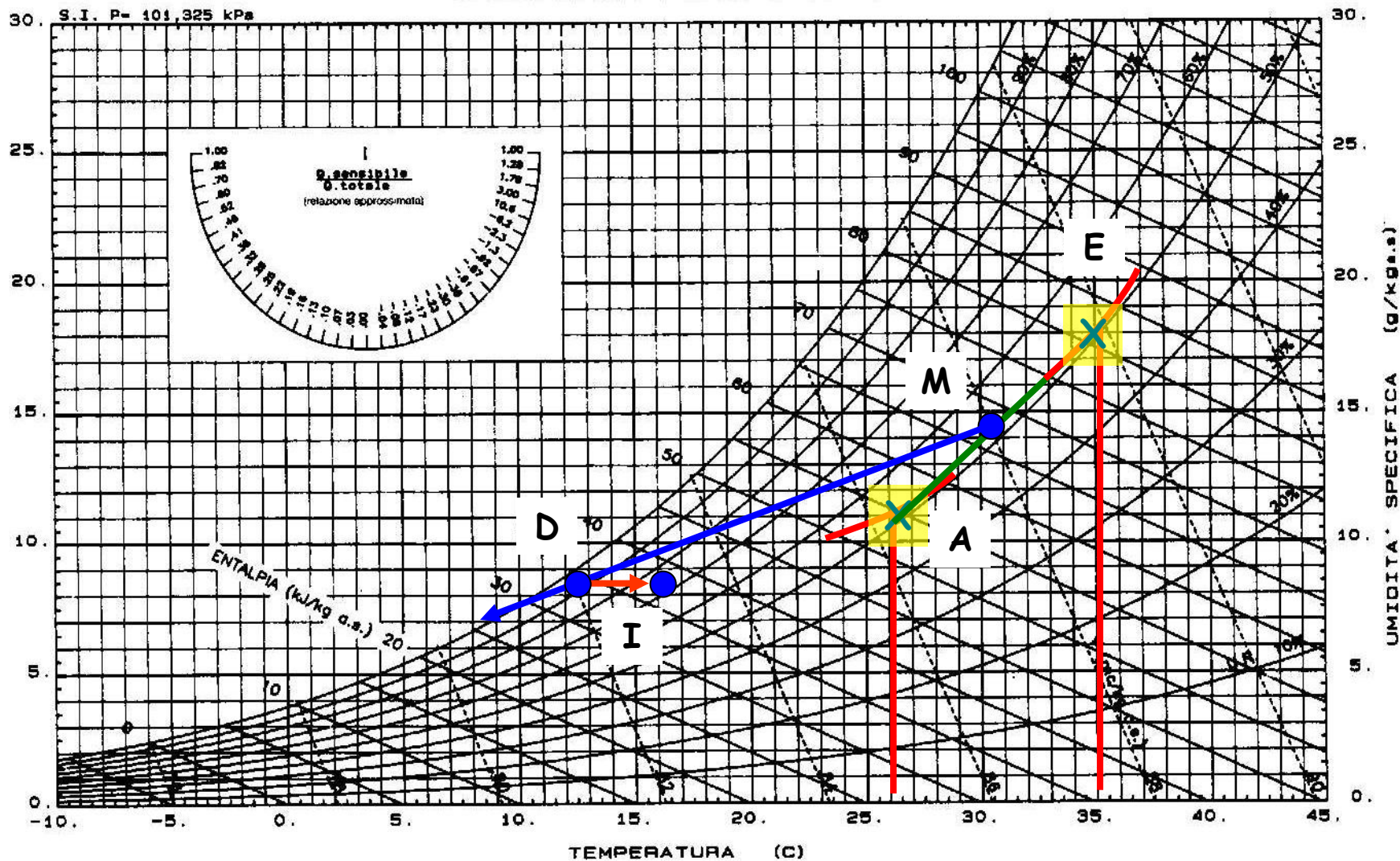

Summer with heat recovery

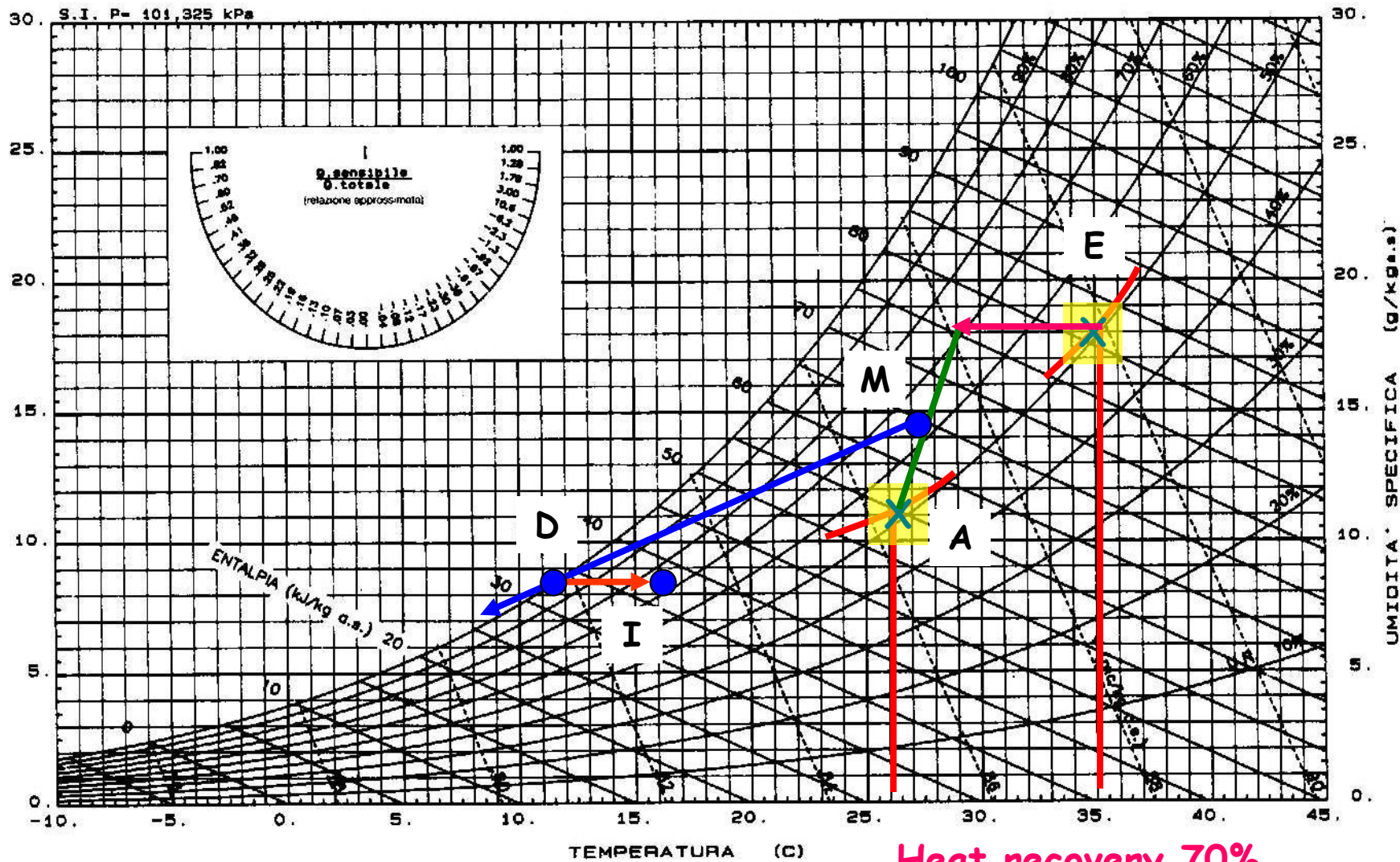

- *Adaptable and Precise* in controlling temperature and humidity
- *With different zones* —→ each with a un **SINGLE DUCT & AHU**

- *Sizing* $\left\{ \begin{array}{l} \text{heating} \\ \text{cooling} \end{array} \right.$

- *Select the greater flow rate as design flow rate*



If there is a difference between the 2 flow rates:

- *maximum*
- *reduced (by means of a fan with variable flow rate)*



In the second case (reduced flow rate) it is necessary to set again the inlet conditions (the inlet conditions change)

HOW TO SIZE THE COILS:

Preheating coil:

$$x_D = x_I \quad (\text{latent load} = 0)$$

$$G_I c_p (t_D - t_M) = \text{heat supplied as preheating}$$

• Reheat coil:

For cooling: $t_I = t_A$ (sensible load = 0)

$$G_I c_p (t_I - t_C) = \text{heat supplied in winter}$$

$$G_I c_p (t_A - t_D) = \text{heat supplied in summer}$$

Whichever is greater

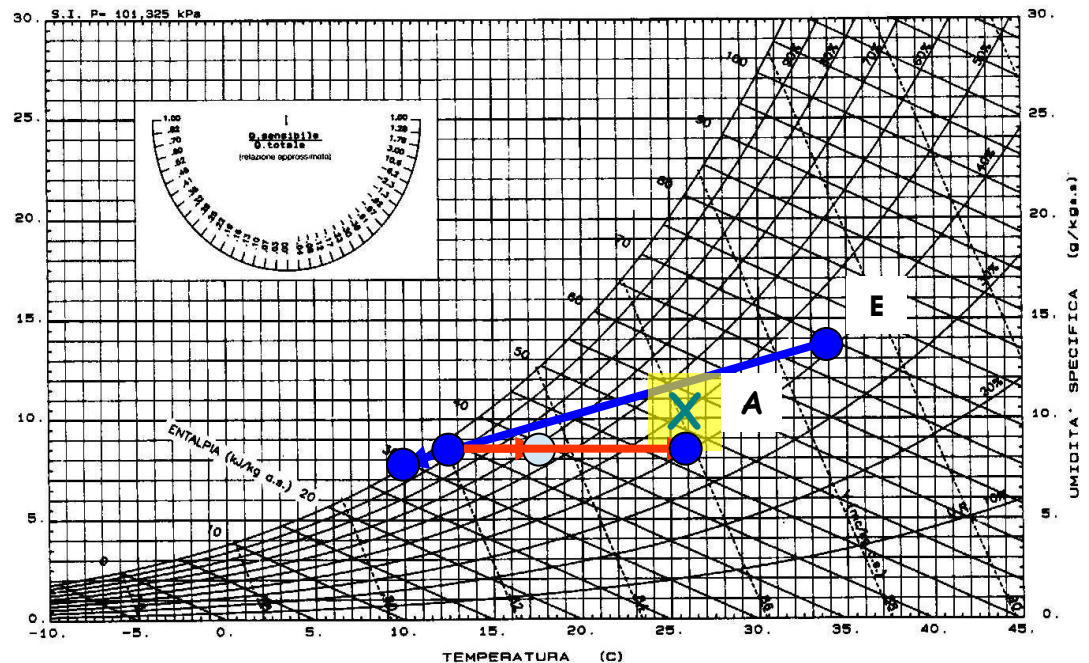

MULTIZONE SYSTEMS WITH REHEAT COILS

- ✓ *Zones with different loads*
- ✓ *There is just one AHU and the reheat coils are installed locally*
- ✓ *The control can be either on the temperature or on the relative humidity (just one of them)*

1. Equalizing dampers
2. Pre-heating coil
3. Atomizing humidifier
4. Droplet separator
5. Cooling coil
6. Reheat coils
7. Fan

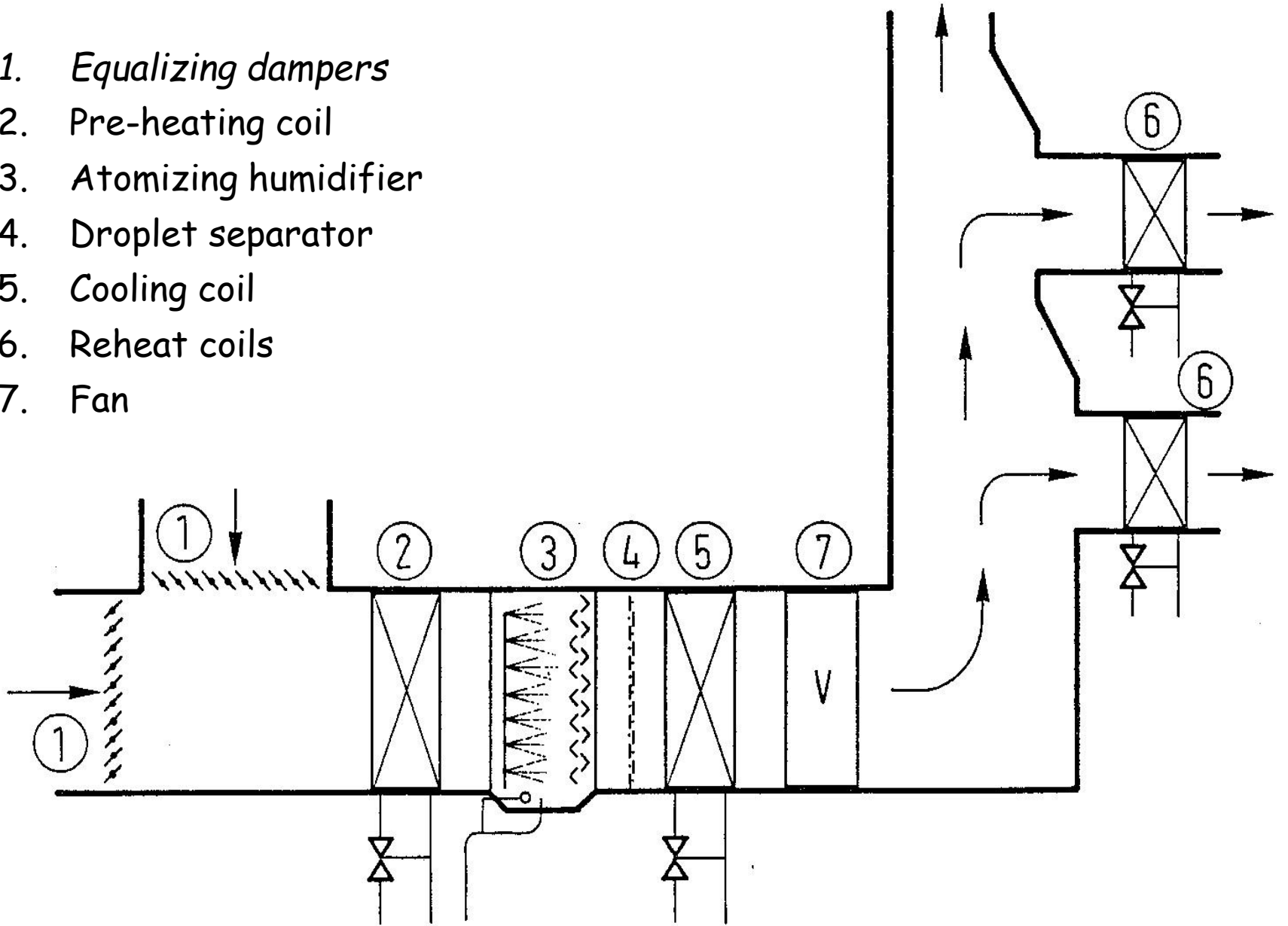

Case with room temperature control:

The control is based on a set-point temperature of the room t_a .

The humidity ratio can change depending on the actual vapour balance. The humidity ratio can vary and hence the conditions A' can move on the red straight segment t_a varying the relative humidity.

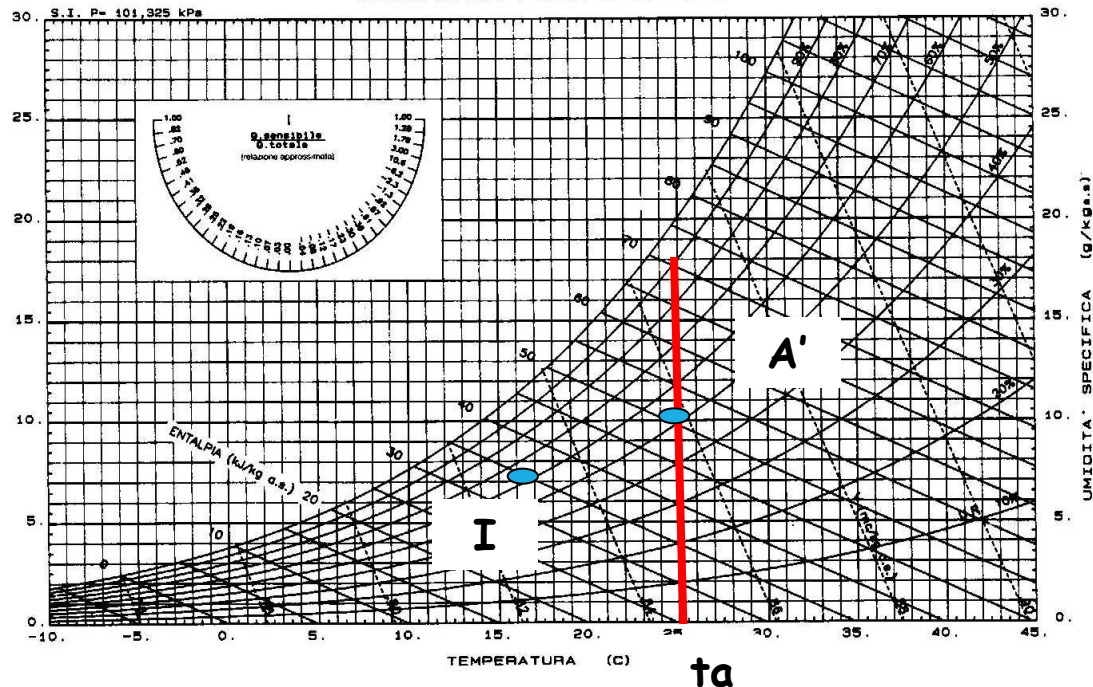

- Sizing the ventilation rate:

$$G_{a\text{ TOT}} = \sum_j G_{aj}$$

$$\frac{G_{a\text{ FRESH}}}{G_a} \quad \text{Room by room}$$

G_a

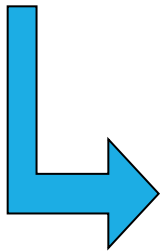

The maximum ratio M determines the sharing of fresh air

$$G_{a\text{ FRESH}} = M G_a$$

Example:

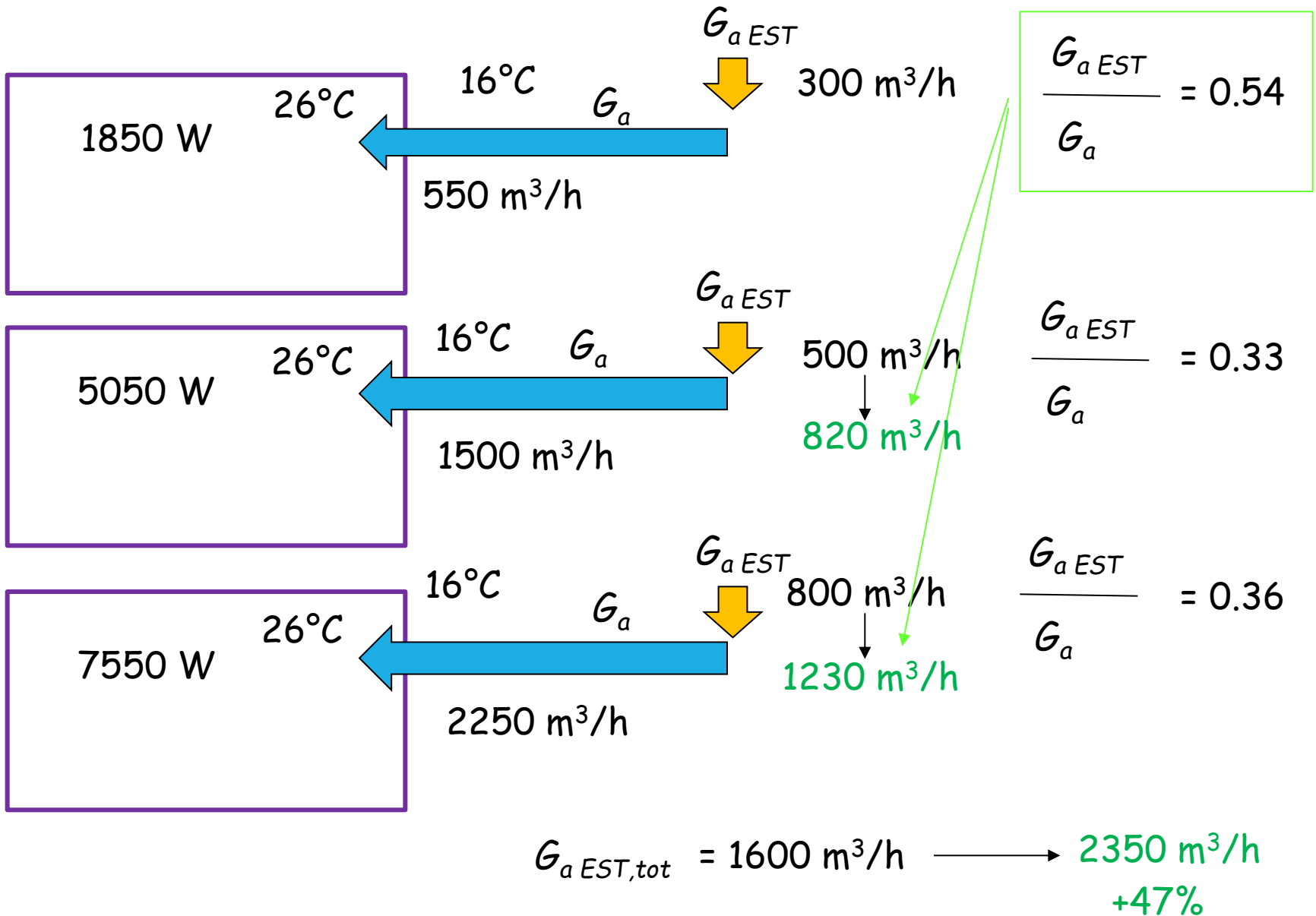

VARIABLE AIR VOLUME

Equations ① and ② can be managed by changing the air flow rate

$$q_p = G_I c_p (t_a - t_I) \quad \text{①}$$

$$G_{vp} = G_I (x_a - x_I) \quad \text{②}$$

Terminal units *with variable geometry* are activated by means of a *servomotor* actuated by a thermostat

The air flows where it is required

Less air flowing in the ducts

1. Equalizing dampers
2. Pre-heating coil
3. Atomizing humidifier
4. Cooling coil
5. Reheat coil
6. (Equalizing damper)
7. Fan

Usually in the farthest point (largest pressure drop)

Today the dampers are not used due to the advances in the engines/fans (brushless technologies) which allow to control the speed of the fan in an easy and efficient way

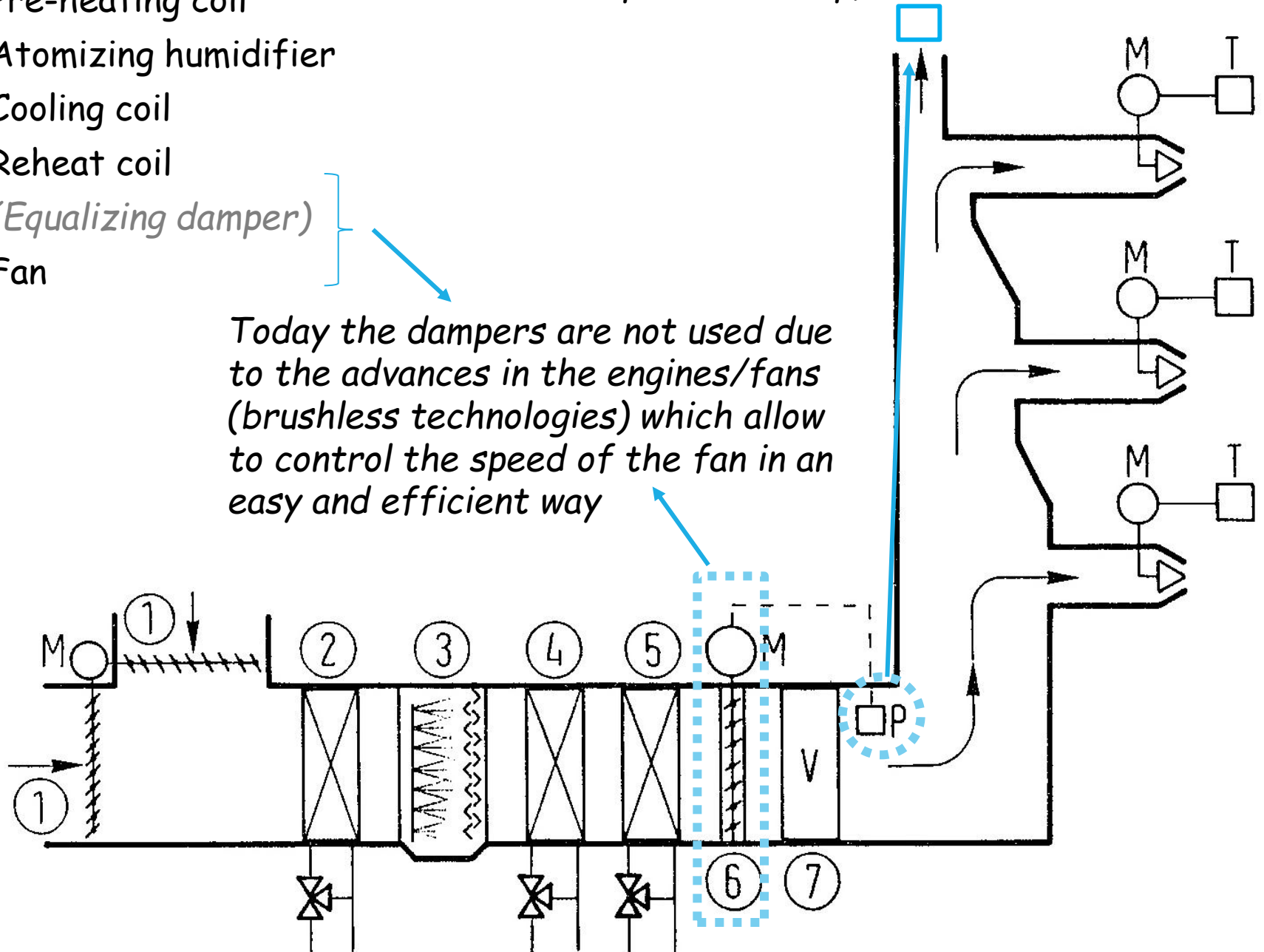

It is important to control the pressure in the main duct (hence on the fan speed) when the damper is activated in order to balance the whole duct system.

This way the variation of the air flow in a zone will not affect the flow rate in other zones.

Hence it is requested that the whole system is an integrated solution.

The flow rate can be lowered down to 20-30% of nominal value. Lowering the rate can lead to a poor IAQ risk. For this purpose equalizing dampers are placed in the fresh air circuit and in the recirculation circuit

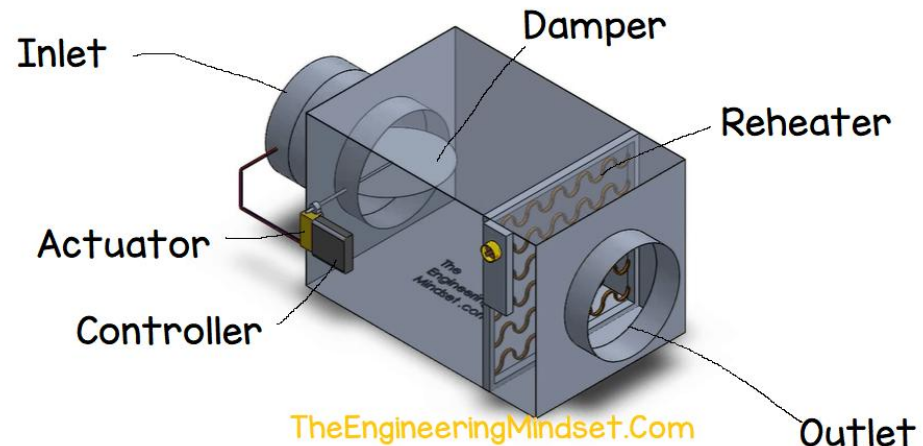

MULTIZONE SYSTEMS WITH REHEAT COILS AND VAV

1. Equalizing dampers
2. Pre-heating coil
3. Atomizing humidifier
4. Cooling coil
5. (Equalizing damper)
6. Local reheat coils
7. Fan

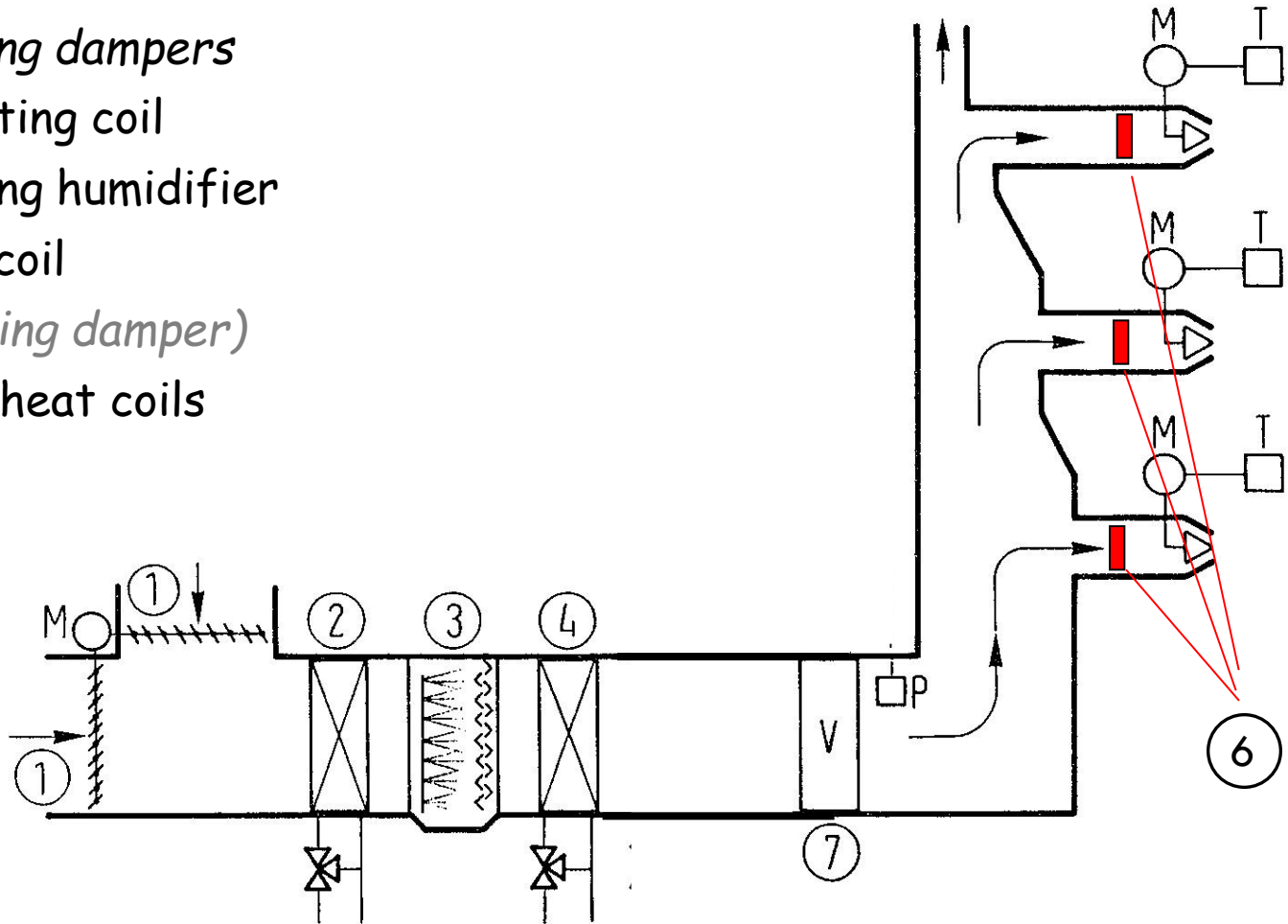

Control strategy: flow rate first and then reheat coil

DUAL PLENUM SYSTEMS

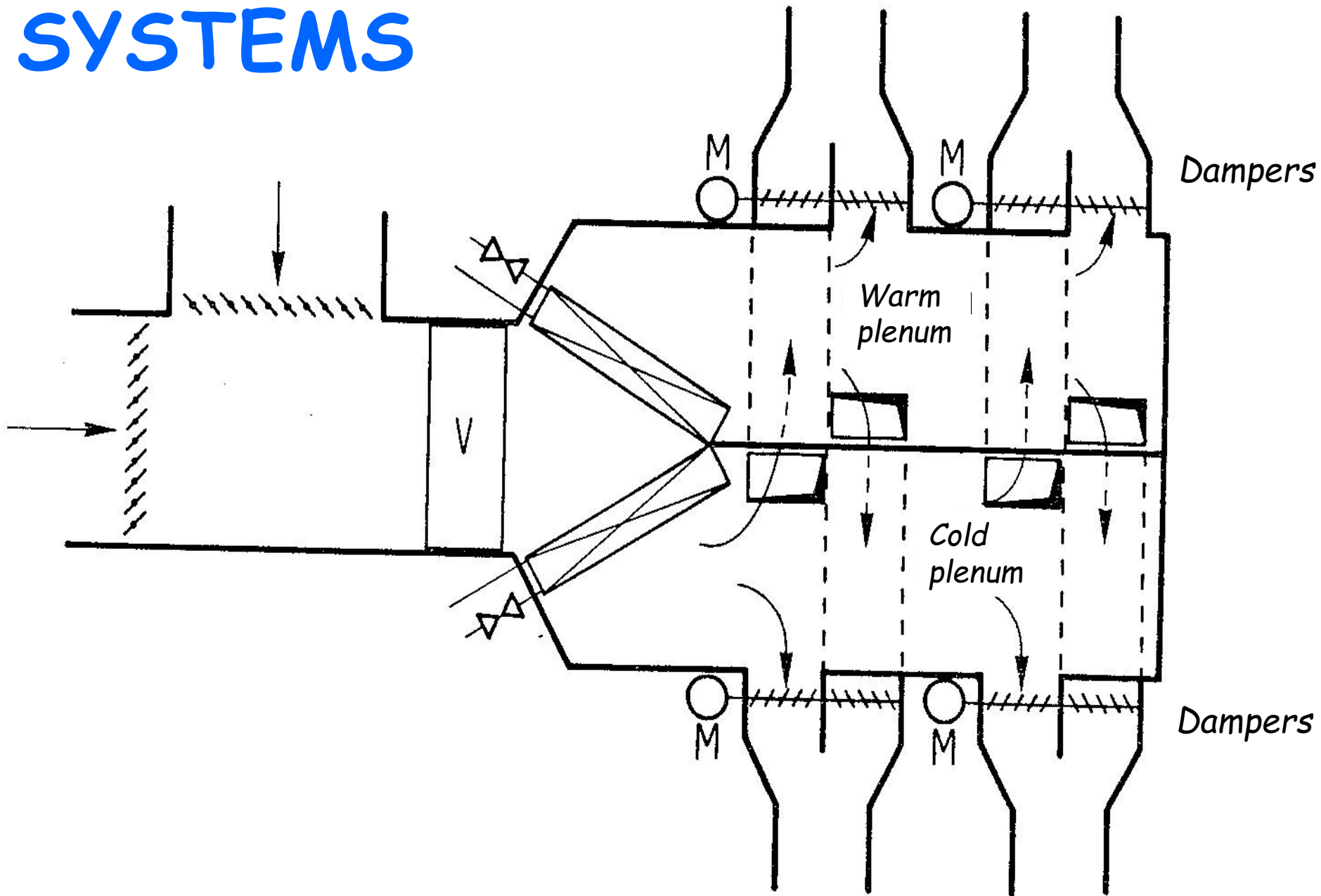

DUAL DUCT SYSTEMS

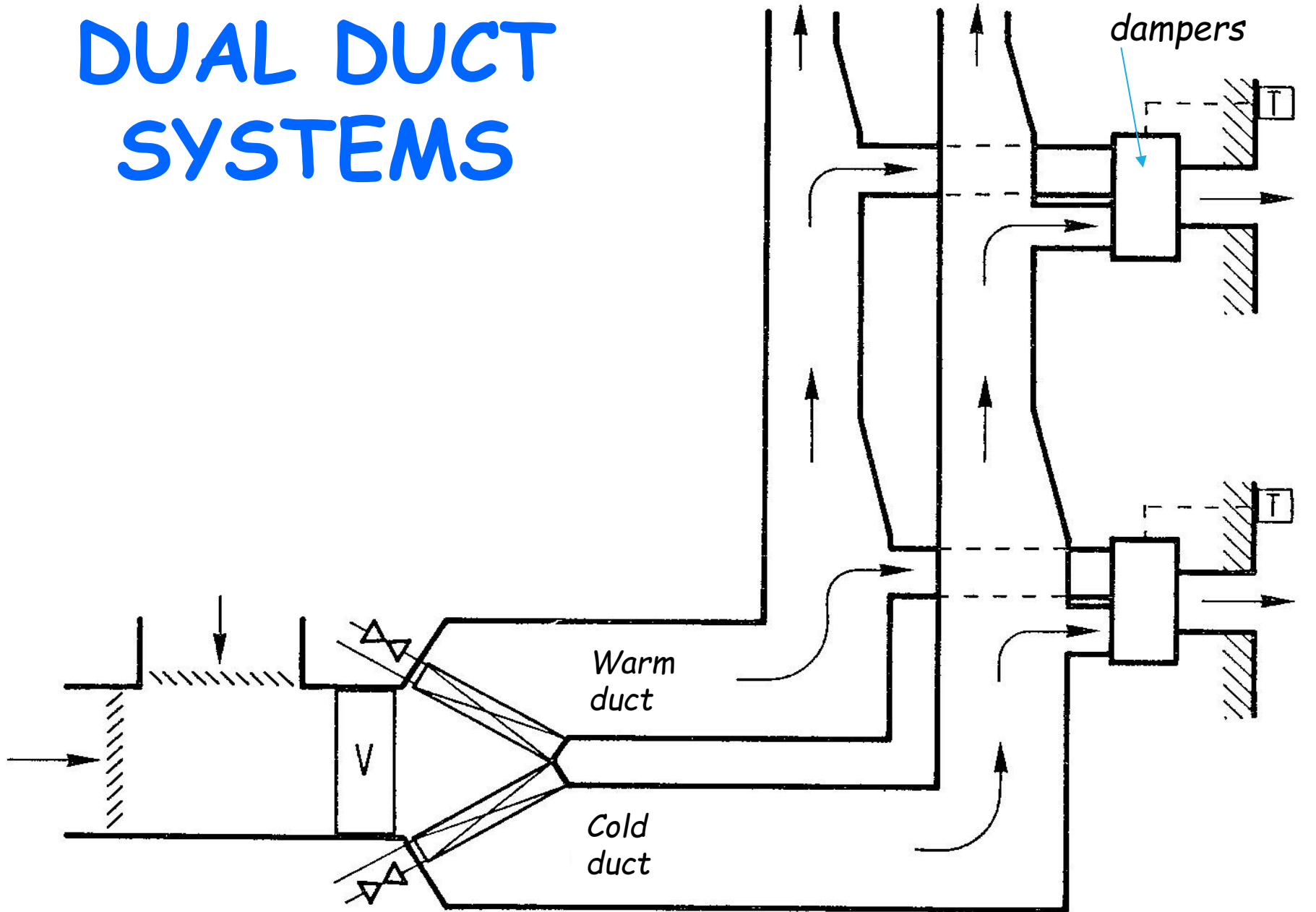

➤ *Low installation costs*

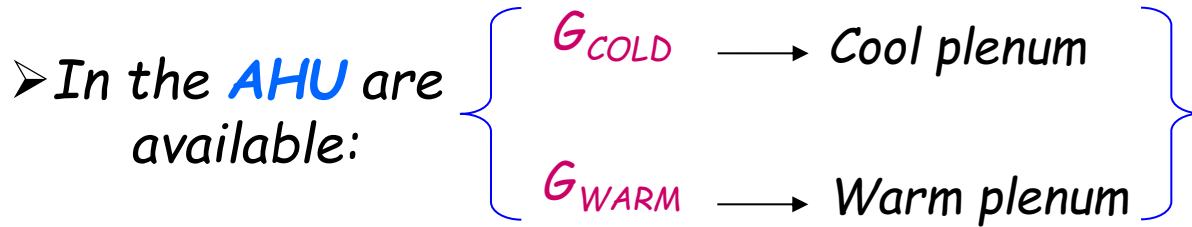

In each zone $G_{Ij} =$ **COST** managing the equalizing dampers **equalizing dampers** which mix the warm and the cold air

➤ The inlet point **I** is easy to keep

➤ Small changes in

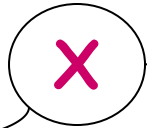

Too low (winter)

Humidifier in the recirculation system

Resulting by the two mixing flow rates

t warm plenum:

• Summer $\longrightarrow t_{ext}$

• Winter $\longrightarrow t_a + 20 \div 25 \text{ }^\circ\text{C}$

t cold plenum:

CONSTANT = $12 \div 15 \text{ }^\circ\text{C}$ \longrightarrow

In winter the cooling coil does not work and the air flow rate varies

$G_{EST} \longrightarrow IAQ$

In cold climates to avoid too low temperatures \longrightarrow

Preheating coils before the fan or heat recovery unit

Variable Air Ventilation (VAV) & Demand Control Ventilation (DCV)

DCV is a particular type of VAV

It is a VAV with automatic control on demand → DCV

VAV

Ventilation with variable flow rate

VAV with automatic control depending on the demand → DCV

Different parameters can be set dealing with thermal comfort and/or IAQ

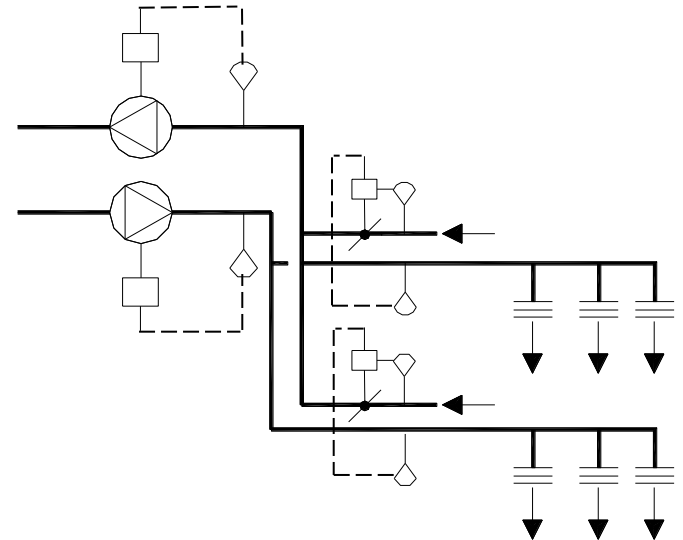

DCV SYSTEM VS. CAV SYSTEM

- **DCV for the comfort control** (heating/cooling load)

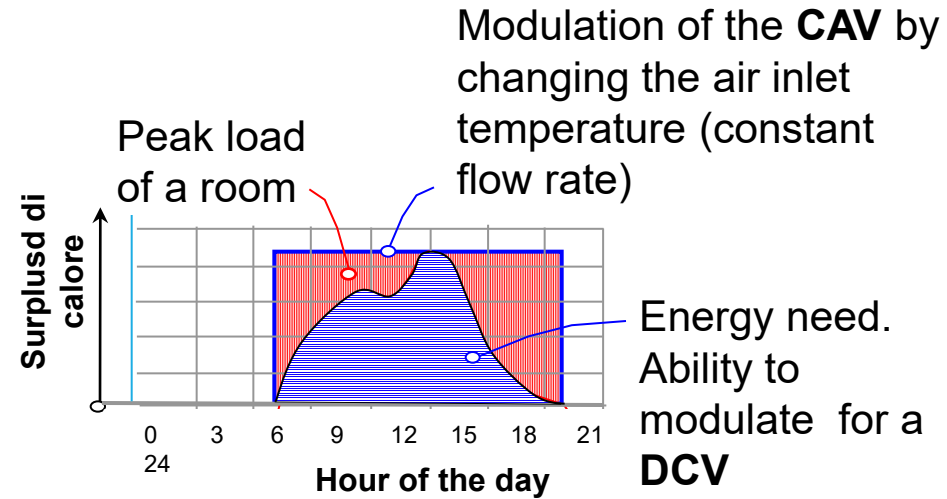

- **DCV for the IAQ control** (pollutant removal)
- A proper marker is the CO_2

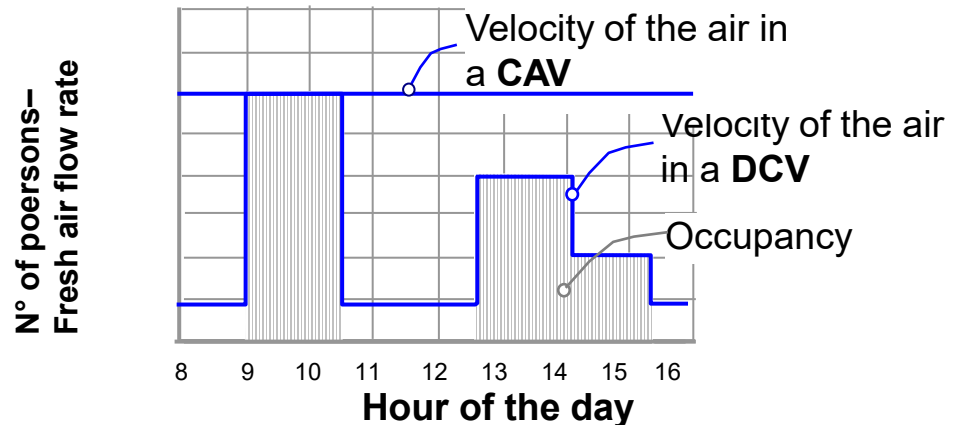

Advantages of a DCV

Possibility to modulate the flow rate of the air all year round (i less electric energy for the auxiliaries)

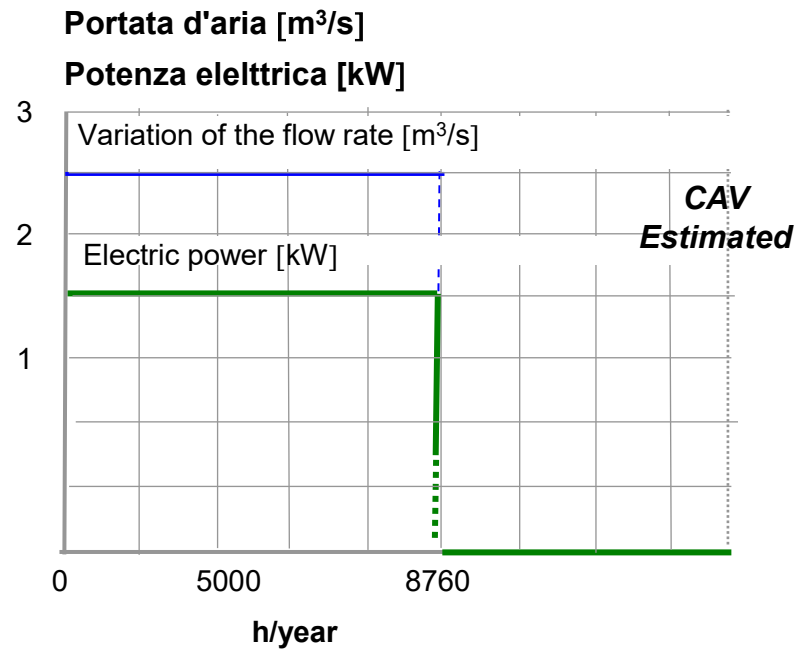
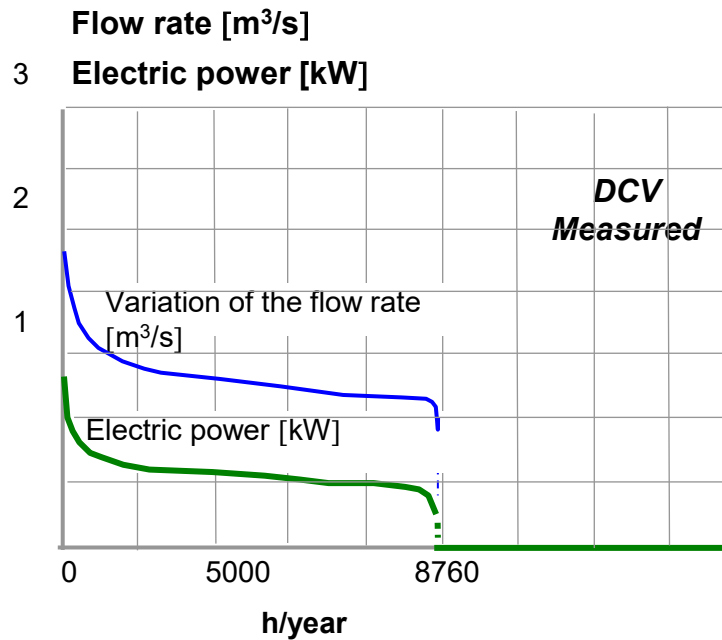

APPLICATIONS OF A DCV

- For buildings with variable loads
 - ✓ Conference centres/auditorium;
 - ✓ Offices;
 - ✓ Restaurants;
 - ✓ Theatres;
 - ✓ Schools
 - ✓ ...

- The greater the variation of the loads, the larger the energy saving



EXAMPLE OF DCV

Retrofit of an office building
(CAV → DCV)

3500 m² with 107 offices

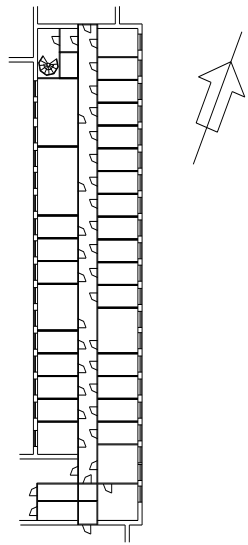

Energy use for ventilation before and after refurbishment

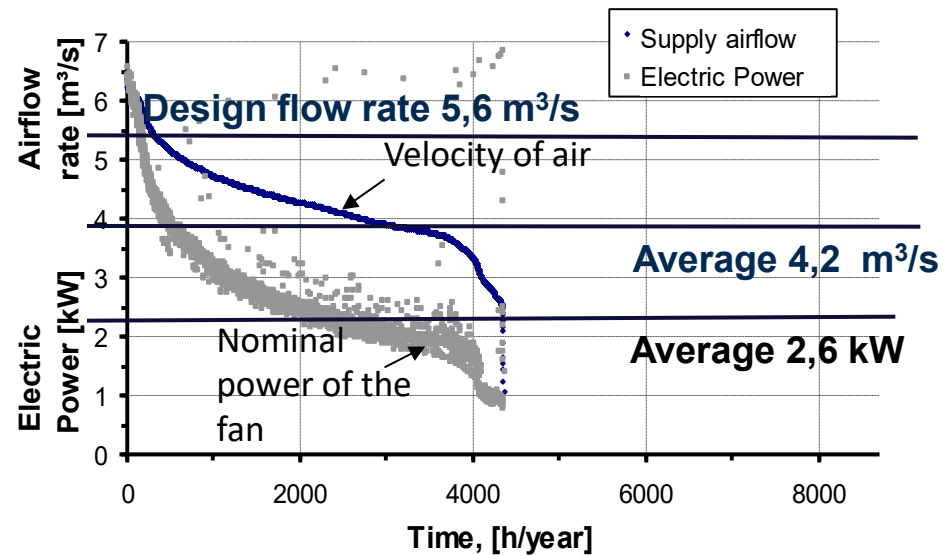
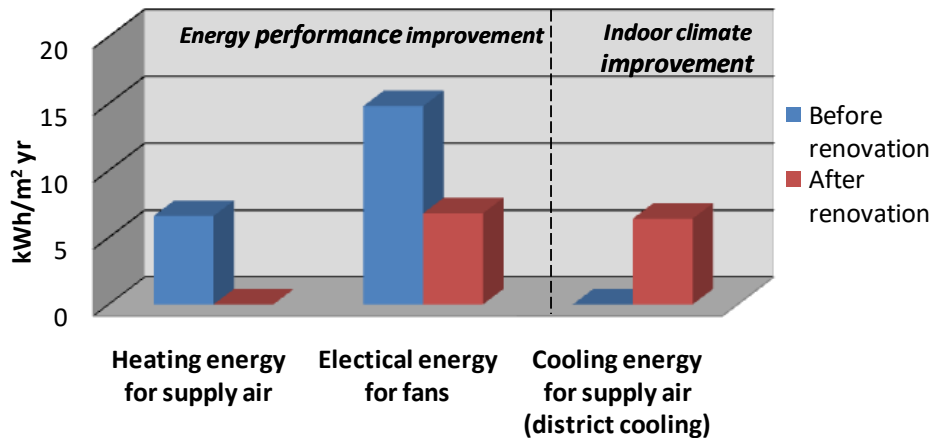

EXAMPLE OF DCV

Retrofit of an office building
(Administrative offices of a University)
2500 m² with 76 offices

