

MASTER'S DEGREE IN ENERGY ENGINEERING

Awarded the EUR-ACE label

OPEN DAY 2023

Padova, 16 May 2023

This Master's degree programme foresees *9 compulsory courses*
(72 CFUs in total)

7 exams are in the first year, 2 exams are in the second year

Year	Sem	Subject	CFU	Hours
1	1	Measurements and Instrumentation	9	72
1	1	Applied Energy	9	72
1	1	Energy Systems	9	72
1	2	Combustion	6	48
1	2	Electric Power Systems	9	72
1	2	Heat Transfer and Thermofluid Dynamics	9	72
2	1	Renewable Energy Technologies	9	72
2	1	Energy Economics	9	72
1		English Language B2 (Productive Skills)	3	

Measurements and instrumentation

GOALS: to provide criteria for instrument selection and methods for their correct use and for the critical evaluation of measurement results.

METHODS: Class and laboratory activities with PC-based data acquisition and processing systems.

CONTENTS:
Static and dynamic characterization of a measuring instrument; uncertainty analysis; operating principle and metrological characteristics of the most used instruments for energy engineering.

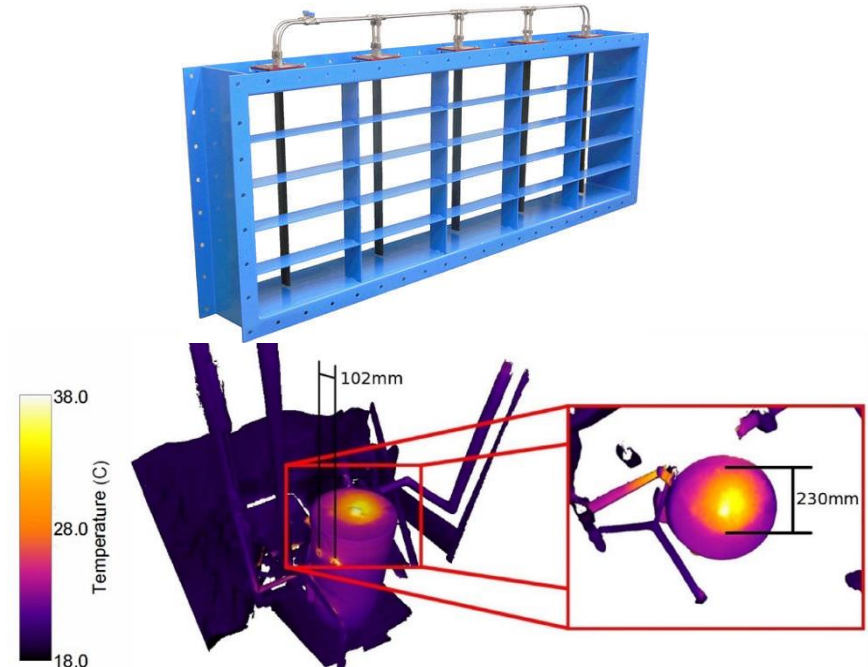

GOALS: Acquire familiarity in the field of energy use in industrial plants. Provide analysis criteria based on the use of LCA techniques and Circular Economy concepts.

METHODS: frontal lessons, lessons in the computer lab, individual exercises, technical visits

CONTENTS: basic concepts on nuclear plants, elements of gas technology, nexus between water and energy, energy distribution through hydraulic circuits in industry, LCA

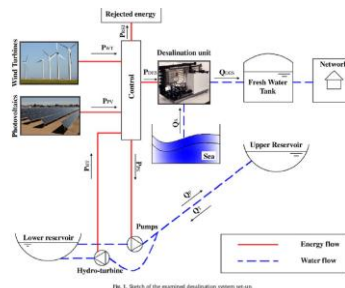

GOALS: Construction of models for predicting the design and off-design performances of renewable and traditional energy conversion systems

METHODS: Lectures and exercises in computer lab

CONTENTS:

- Simultaneous and sequential approaches
- Design and off-design models of the main energy systems components (turbomachines, heat exchangers, ..) and power plants in EES ® (simultaneous approach) and Matlab-Simulink ® (sequential approach) environment
- Exergo-economic analysis, optimization of heat exchangers networks, innovative methods for the design optimization of complex energy systems configurations

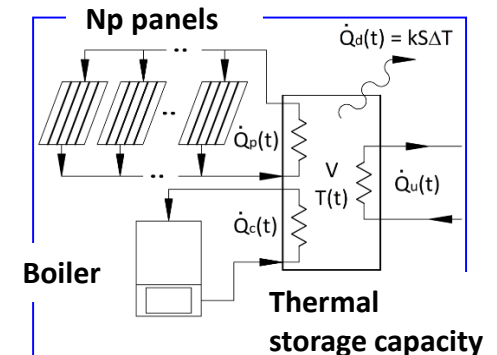
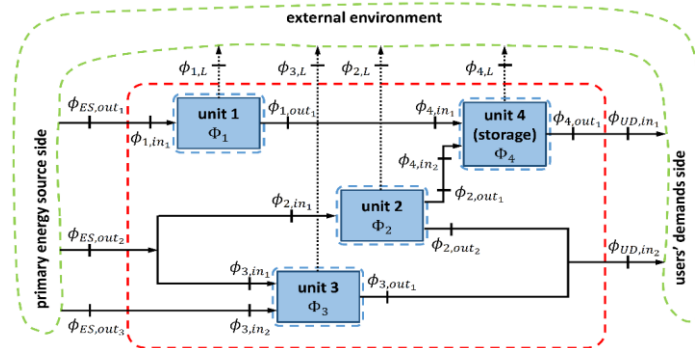
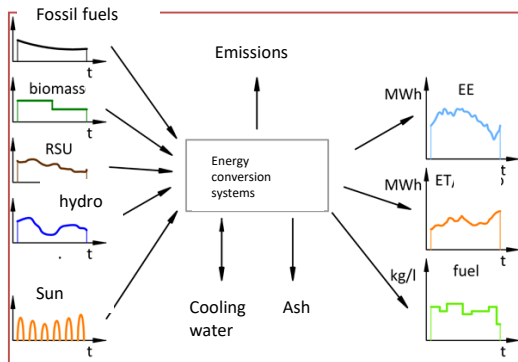

Goals

Understand physical and chemical mechanisms
controlling fuels oxidation



Methods

Traditional and on-line lessons
(in english), online self-evaluations,
tours to local companies

Contents

- Constraints to internal energy conversion into heat
 - 1) thermodynamics
 - 2) chemical kinetics
 - 3) rate of heat and mass transfer
- Premixed (gas) flames
- Diffusive flames of gas, liquid or solid fuels
- Emissions control

Heat Transfer and Thermofluid Dynamics

OBJECTIVES: Heat exchangers DESIGN
and FINITE ELEMENTS analysis with
computer.

METHODS: lectures, LABORATORY,
TEAM WORK: design of a heat exchanger

CONTENTS: single phase heat transfer,
condensation, boiling, numerical methods.
Heat transfer enhancement.

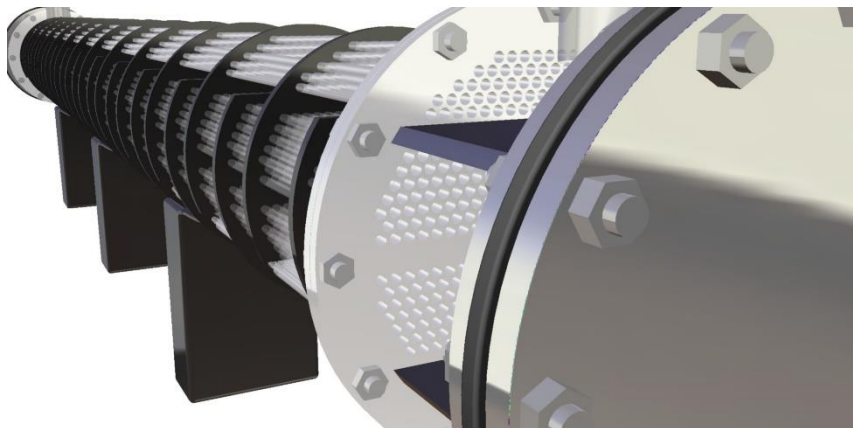

(a) Velocity
Contour 1

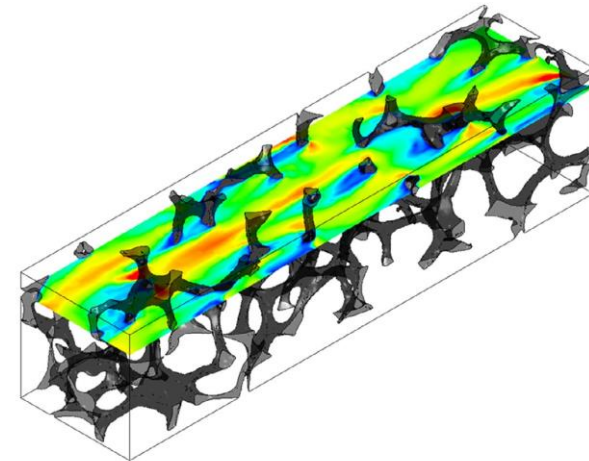
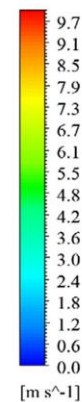

(b) Temperature
Contour 1

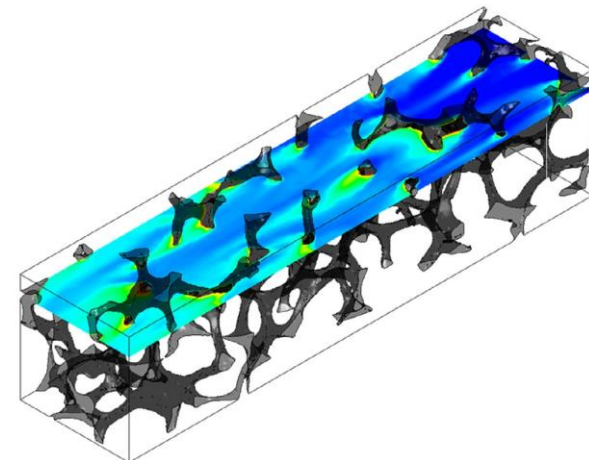
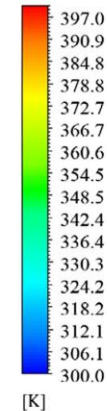

Electric Power Systems

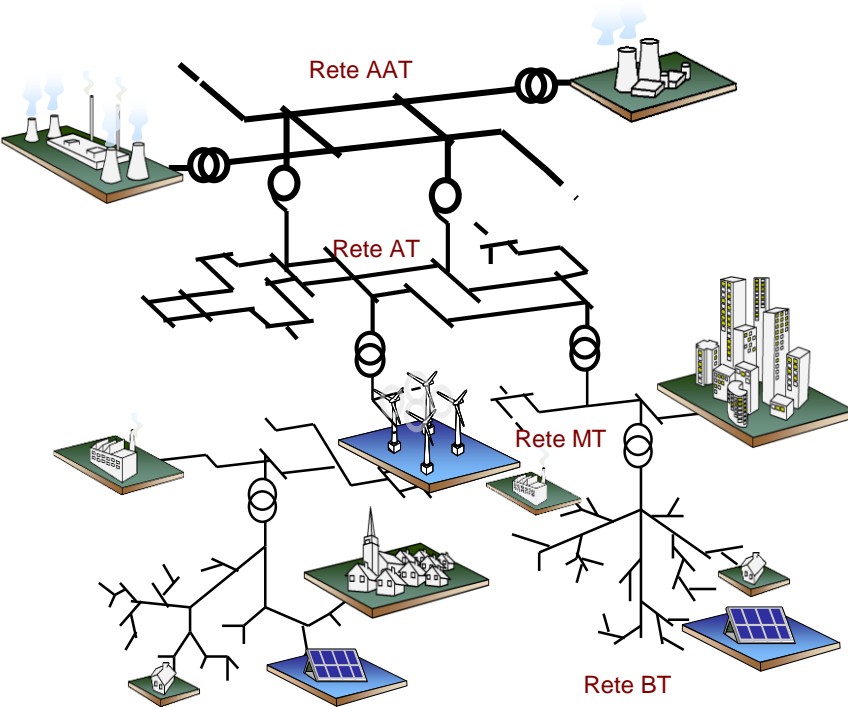

GOALS: Acquisition of the knowledge bases for the constitution and operation of a large electrical system. Methods of analysis in the various functional regimes.

METHODS : Lectures, informatic lab exercises

CONTENTS:

- Structure of a Power System.
- Transmission Lines.
- Power Flows analysis.
- Reactive Power and Voltage Control (Voltage stability and Voltage collapse).
- Active Power and Frequency Control (Steady state and Transient System stability).
- Stability of interconnected systems.
- Overcurrent and Overvoltage System Protection.

GOALS: provide advanced knowledge on technologies and systems for the exploitation of renewable sources

METHODS: lectures, numerical exercises, sizing of plants, solar energy laboratory, project work

CONTENTS:

- solar radiation, solar thermal systems, photovoltaic systems, solar cooling
- geothermal systems, geothermal plants for power generation, geothermal heat pumps
- wind energy, exploitation of solid biomass

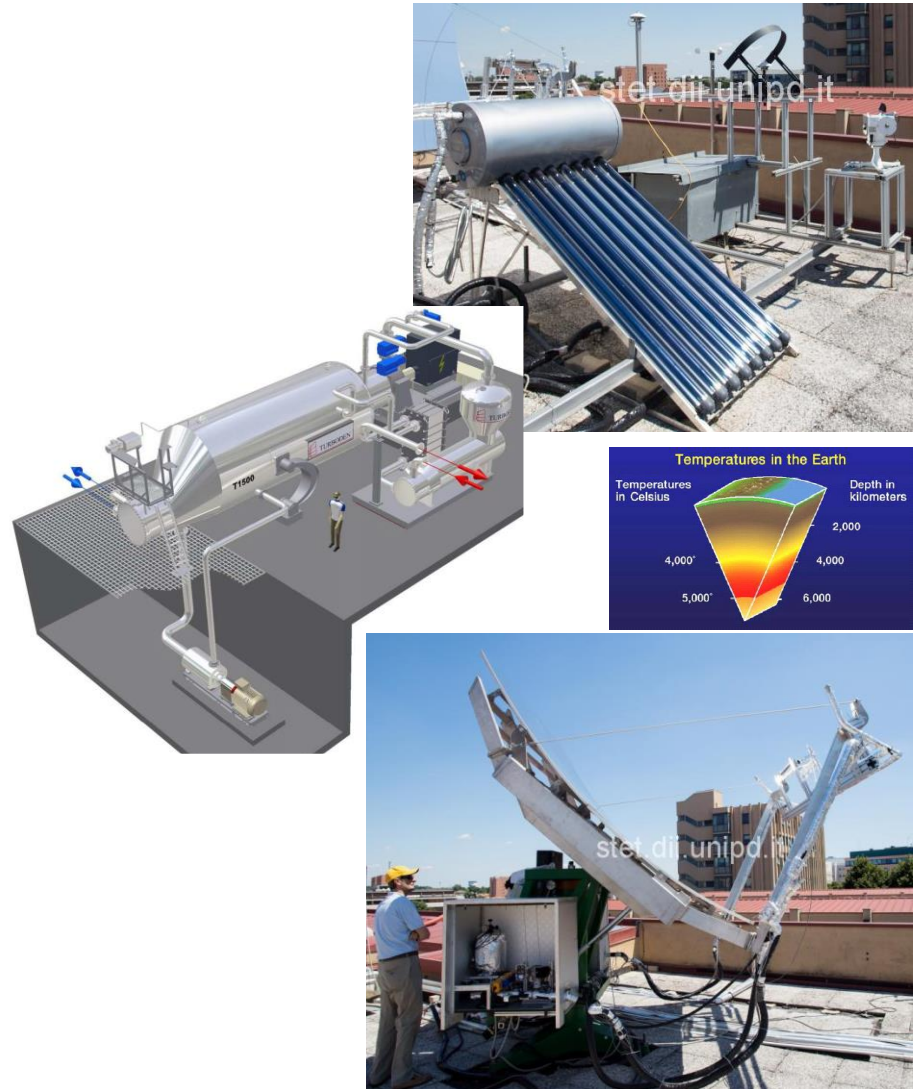

Energy Economics

Target :

Achieving a basic knowledge of energy markets and evaluating energy investments. The student will be able to make a market analysis and to manage a project from the economic and technical perspective

Examination methods:

Written exam during the course, oral exams along the year

Course contents:

Energy sector basic knowledge. Exhaustible resources economic analysis, the Hotelling rule, the role of financial markets. Prices and market of fossil fuels. Market equilibria under competition, oligopoly and monopoly. Economic evaluation of energy investments; the role of uncertainty. The electricity sector, organization and operation.

This Master degree foresees 2 exams (15 CFUs) that can be chosen by each student among a limited list (constrained choice). This list depends on the profile selected by the student

1. *Sustainable Energy Utilization*
2. *Sustainable Power Generation*
3. *Free profile*

There are 15 CFUs more that can be chosen freely by the student (autonomous choice), although a list of possible subjects is suggested depending on the profile

Finally, 18 more CFUs are obtained with the Master's thesis and final exam.

Profile: Sustainable Energy Utilization

Courses for constrained choice
15 CFUs *must* be taken among these
subjects

Subject	CFU
Green Power Conversion and Utilization	6
Heating Ventilation Air Conditioning Systems	9
Energy and Buildings	6
Refrigeration and Heat Pump Technology	9

Courses for autonomous choice
15 CFUs *can* be taken among these
subjects

Subject	CFU
Advanced Control Systems	6
Cogeneration and Combined Plants	6
Green Power Conversion and Utilization	6
Heating Ventilation Air Conditioning Systems	9
Energy and buildings	6
Refrigeration and Heat Pump Technology	9
Applied Acoustic and Design for Product Sound Quality	6
Laboratory of Computational Thermo-Fluid Dynamics	3
Laboratory of Energy Audit	3
Laboratory of Applied Thermodynamics	3

Profile: Sustainable Power Generation

Courses for constrained choice
15 CFUs *must* be taken among these
subjects

Subject	CFU
Nuclear Fission and Fusion Plants	9
Cogeneration and Combined Plants	6
Green Power Conversion and Utilization	6
Process technologies for carbon-neutral fuels	6
Wind and Hydraulic Turbines	9

Courses for autonomous choice
15 CFUs *can* be taken among these
subjects

Subject	CFU
Advanced Control Systems	6
Green Power Conversion and Utilization	6
Cogeneration and Combined Plants	6
Nuclear Fission and Fusion Plants	9
Process technologies for carbon-neutral fuels	6
Wind and Hydraulic Turbines	9
PV science and technology	6
Design and optimization of sustainable energy systems	6
Laboratory of Applied Thermodynamics	3
Laboratory of Computational Thermo-Fluid Dynamics	3

Profile: Free

Courses for constrained choice
15 CFUs *must* be taken among
these subjects

Subject	CFU
Nuclear Fission and Fusion Plants	9
Cogeneration and Combined Plants	6
Green Power Conversion and Utilization	6
Process technologies for carbon-neutral fuels	6
Wind and Hydraulic Turbines	9
Heating Ventilation Air Conditioning Systems	9
Energy and buildings	6
Refrigeration and Heat Pump Technology	9

Goals:

understanding the operating principles and the main characteristics of electric drives for a sustainable power conversion and utilization.

Methodology:

classroom lessons and practical lab sessions

Topics:

Electric power conversion (inverter/rectifiers) and supplying of electrical machines by means of power converter (electric drives). Grid connection of renewable resources. Efficiency improvement adopting variable speed electric motors and generators.



Main components of an electric drive



Grid connection of
PV systems

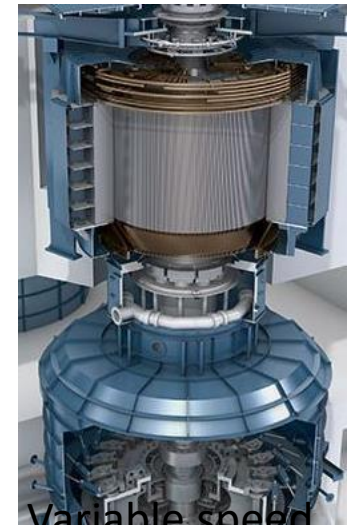

Variable speed
hydroelectric
power plant

Energy & Buildings

Goals: Learn energy consumptions in buildings and how to reduce them

Methods: Theory and practice. Use of tools: 2-D conduction in walls and 3-D dynamic simulation of the building with SKETCHUP and ENERGYPLUS. Write a report.

Contents: comfort (thermal and visual), energy balance of a building, energy consumptions in buildings, Building Management Systems, Zero Energy Buildings, Plus Energy Buildings, multi-source systems, energy in districts

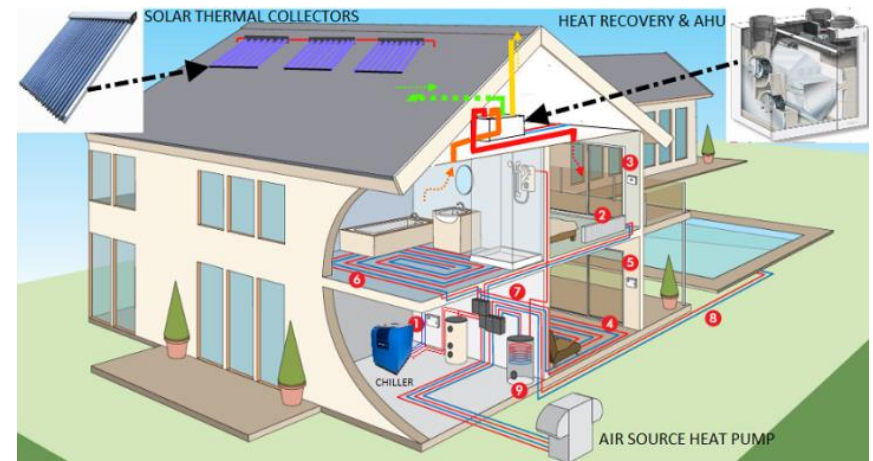
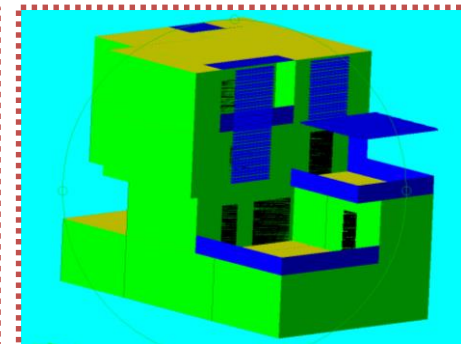
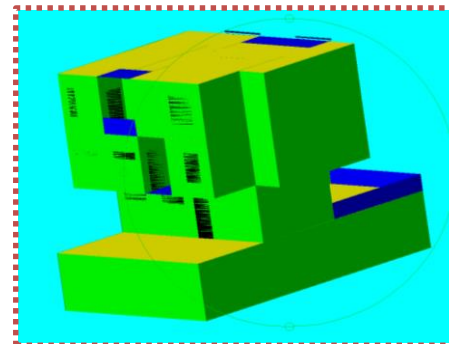
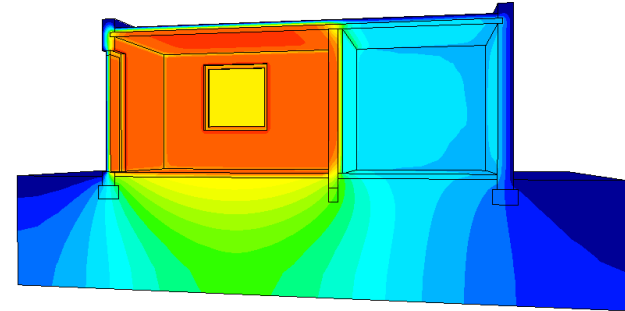

Heating Ventilation Air Conditioning Systems

Goals: Learn the sizing and operation of hydronic and aeraulic systems for heating and cooling applications

Methods: Theory & practice. Excel and Word: calculation sheets on air handling units (AHU), size of radiant systems, balance hydronic circuits. Write a report.

Contents: Ventilation & IAQ, sizing a ventilation system, AHU components. Emission systems (radiators, radiant systems, etc.), tanks, valves, control, hydronic systems sizing and balancing. Management and sizing of boilers, heat pumps and chillers. District networks

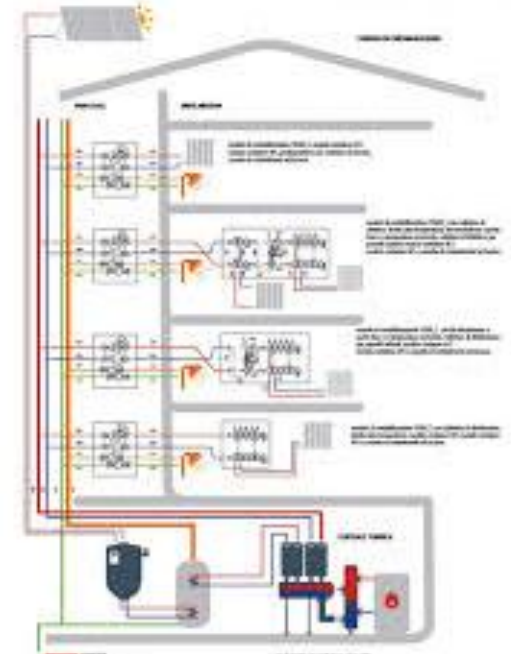
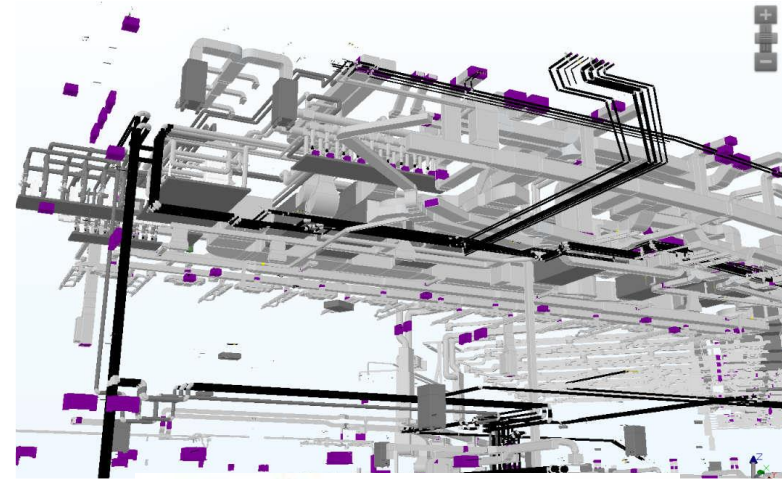

Refrigeration and Heat Pump Technologies

GOALS: study of systems and components for refrigeration and heat pump applications

METHODS: lectures, laboratory, project work

CONTENTS:

- analysis and selection of components depending on application
- adoption of new low-GWP refrigerants
- design of heat pumps, A/C and refrigeration equipment
- refrigeration and heat pump systems using CO₂ as the refrigerant

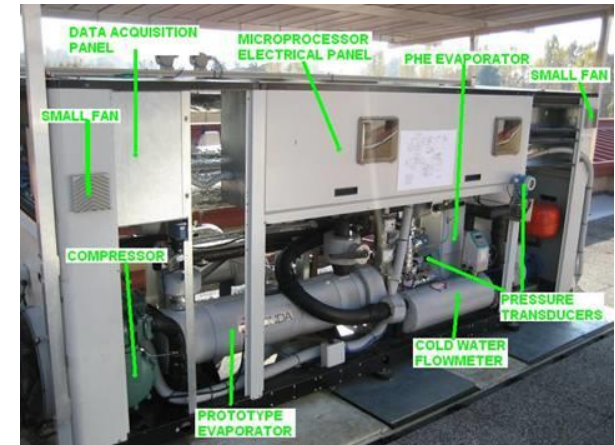
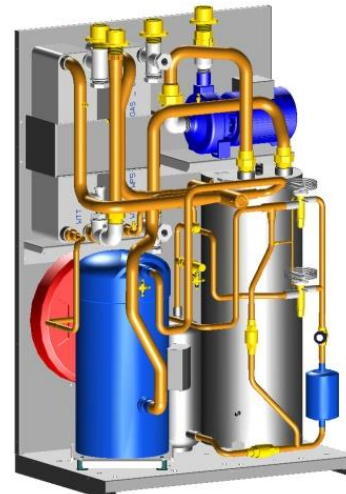
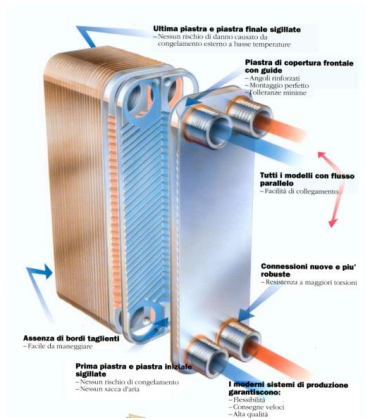
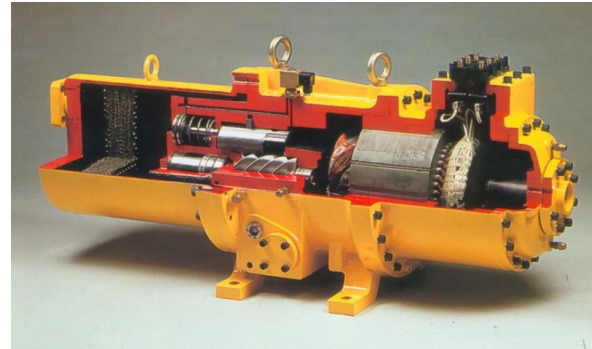

Cogeneration and Combined Plants

GOALS: Acquire familiarity with the main characteristics of combined cycle gas turbines and CHP systems, their design and operation

METHODS: frontal lessons, lessons in the computer lab, individual exercises, group projects, technical visits

CONTENTS: Gas Turbine Combined plants, Combined heat and power plants, sizing and management of cogeneration systems for residential and industrial users

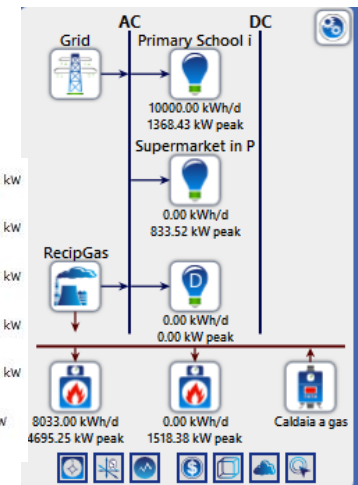
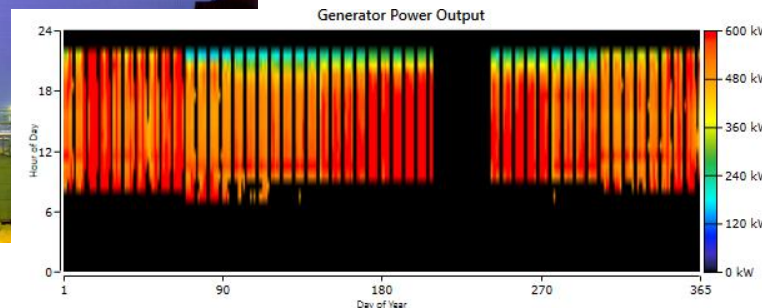

Process technologies for carbon-neutral fuels

GOALS: study and assess industrial processes for sustainable fuel production, CO₂ capture, sustainable hydrogen production

METHODS: lectures, analysis of case studies, teamwork

CONTENTS:

- Biofuel production processes
- Carbon capture, utilization, and sequestration
- Hydrogen production
- Sustainable industrial scenarios: water footprint reduction, e-refineries, carbon-negative production systems
- Ethics and social responsibility in engineering

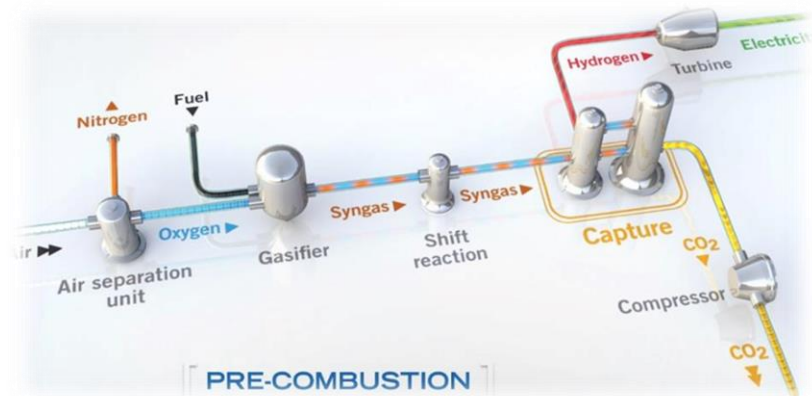

Subject Description: *DESIGN* and *OPTIMIZATION* of wind and hydraulic turbines in the context of a mini and micro production. *PREDICTION* of operating conditions even by Computational Fluid Dynamics (CFD) at real operating conditions.

Methods: Frontal lectures in English, group *PROJECT*

Course Outline

Studies and analyses of urban, suburban and off shore sites

Design criteria for horizontal, vertical axis Wind Turbines and DAWT solutions.

Hydraulic Turbine design criteria focused on the solutions of mini plants (up to 10 MW) with low environmental impact and fish-friendly solutions.

Evaluation of operating conditions, even non-stationary and/or for ancillary network regulation.

Fluid dynamic analyses by computer analysis (ANSYS).

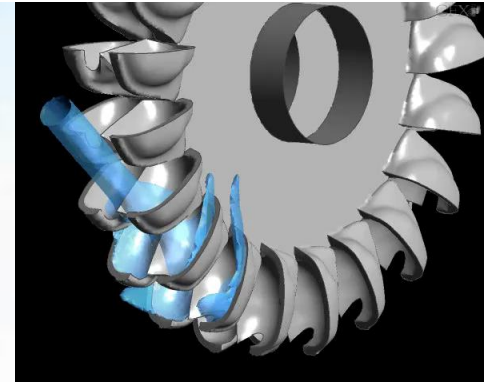
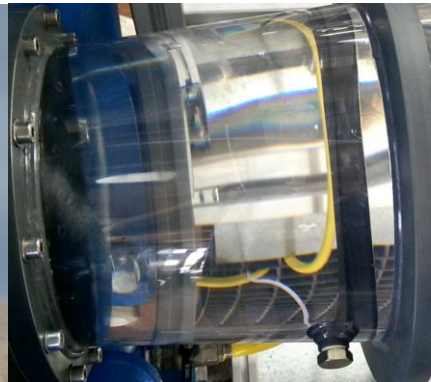

OBJECTIVES: Understanding the working principles and the manufacturing processes of photovoltaic devices, design PV plants and exploit their maximum efficiency

METHODS: frontal lessons, Laboratory, homeworks and group Project

CONTENTS:

PV science The solar radiation and analysis of the spectrum.

Detail analysis of the working principle and building blocks of solar cell.

PV technologies Solar cell and PV module anatomy. Silicon and thin film technologies, from raw material to final product, new photovoltaic technologies

PV design Design of PV plants and maximization of their efficiency and economical analysis

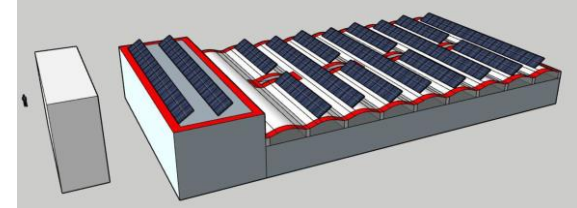
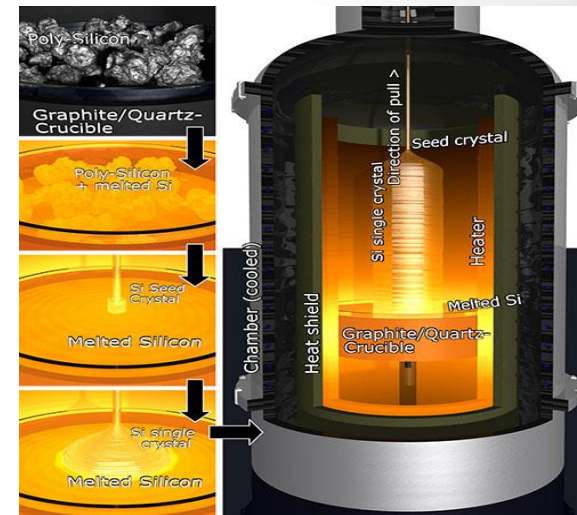
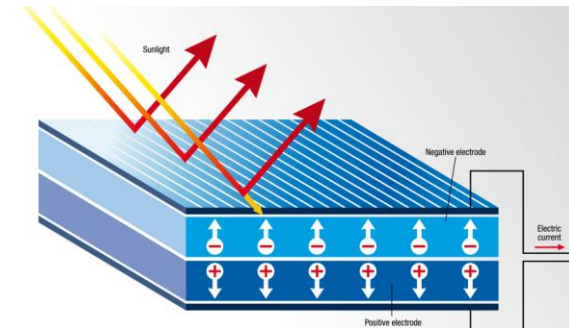

Advanced control systems

OBJECTIVES: Design of advanced feedback control systems for SISO and MIMO plants, in continuous- and discrete-time

TEACHING METHODOLOGIES: Lecturing at the blackboard, aided by slides and Matlab/Simulink simulations

CONTENTS

Advanced PID control architectures

Discretization of continuous-time controllers

Observer-based controllers in state space for MIMO plants

Optimal control

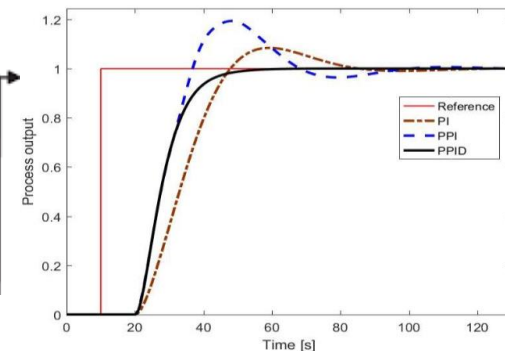
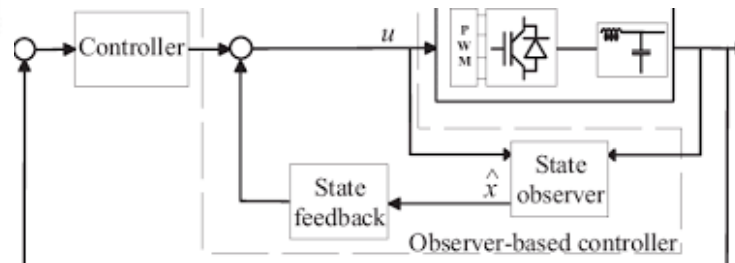
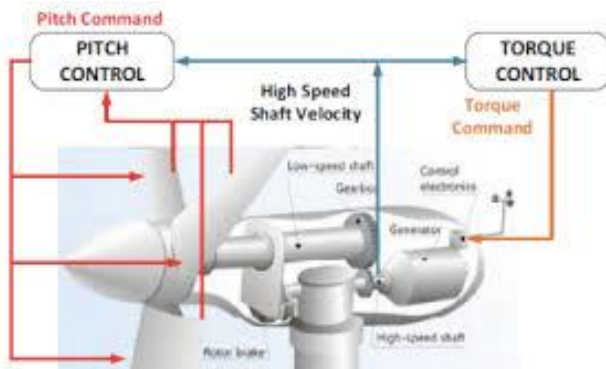

Design and optimization of sustainable energy systems

GOALS: modeling and design-operation optimization of multi-energy systems, where fossil-fuelled energy systems give way to renewable and sustainable ones

METHODS: Lectures and exercises in computer lab

CONTENTS:

- Mixed-integer (non) linear programming for simple but realistic modeling of energy systems
- Dynamic modeling and energy storage
- **Alternative energy carriers (e.g., H₂)**
- Strategies towards a 100% renewable energy scenario
- Centralized and distributed energy generation
- The aggregation in Energy Communities

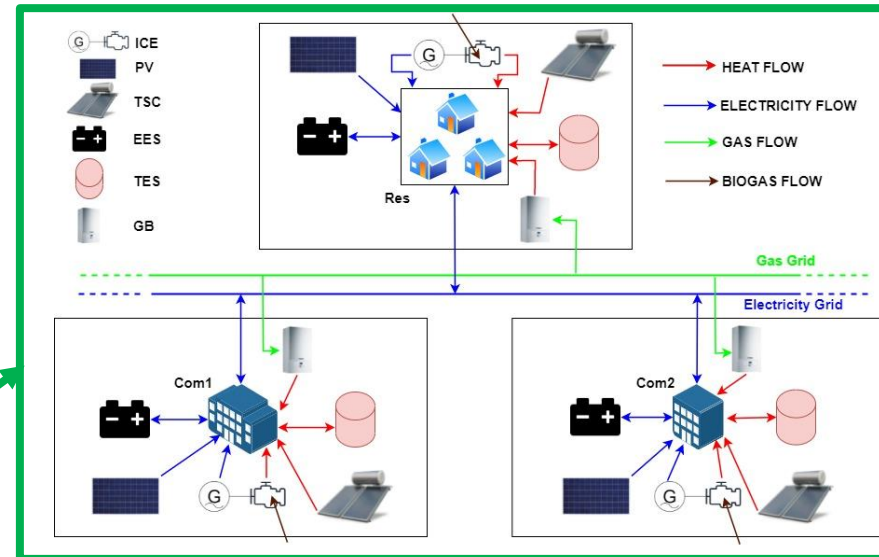
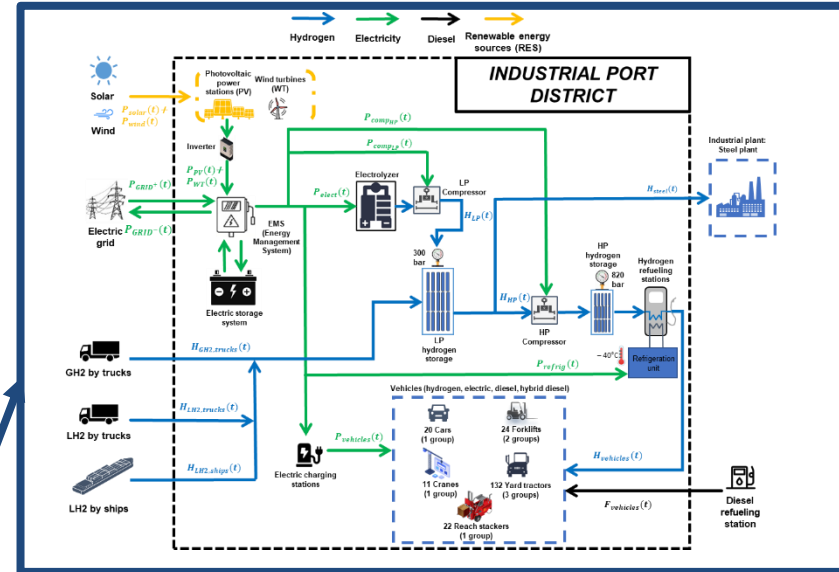

Applied Acoustic and Design for Product Sound Quality

GOALS: Analysis and problem-solving of noise generation and propagation in machinery and service equipment. Design of acoustic improvements for a better quality of products, living environments, and workplaces.

METHODS: Lectures, laboratory activities, case studies, exercises, and group projects.

CONTENTS: Analysis of sound generation and propagation. Evaluation of the sound emission of machines and devices. Characterization, design, and optimization of sound-insulating and sound-absorbing materials and systems for civil and industrial applications. Environmental noise measurements and action plans for noise pollution monitoring and control.

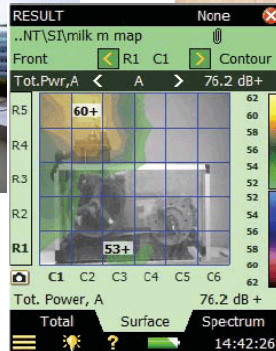
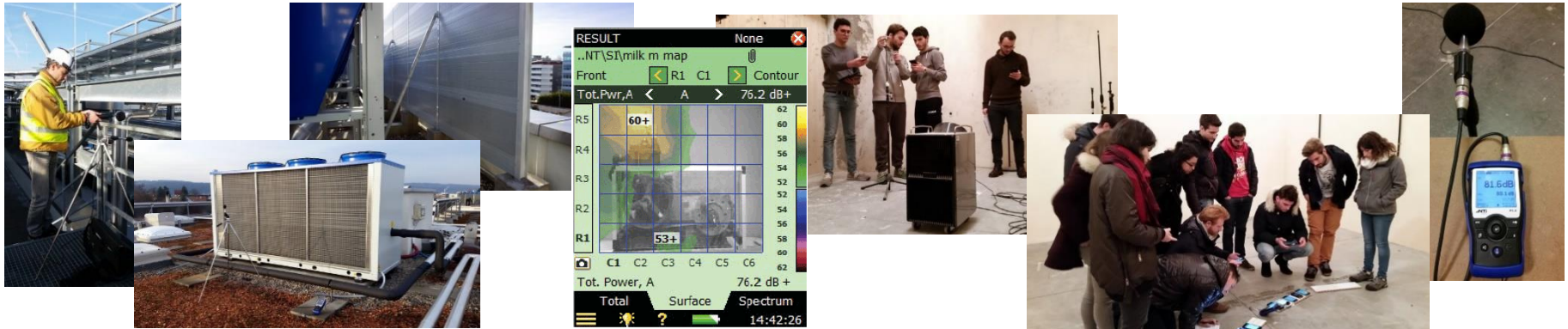

GOALS: provide an introduction to the numerical simulation of heat transfer problems by providing students with the practical elements necessary for a correct use of Computational Thermo-Fluid Dynamics software.

METHODS: lessons, activity in the computer lab, individual exercises.

CONTENTS:

Numerical methods in Computational Thermo-Fluid Dynamics: the finite volume method. Heat conduction. Introduction to commercial CFD code Ansys Fluent. Convective heat transfer. Two-phase flows.

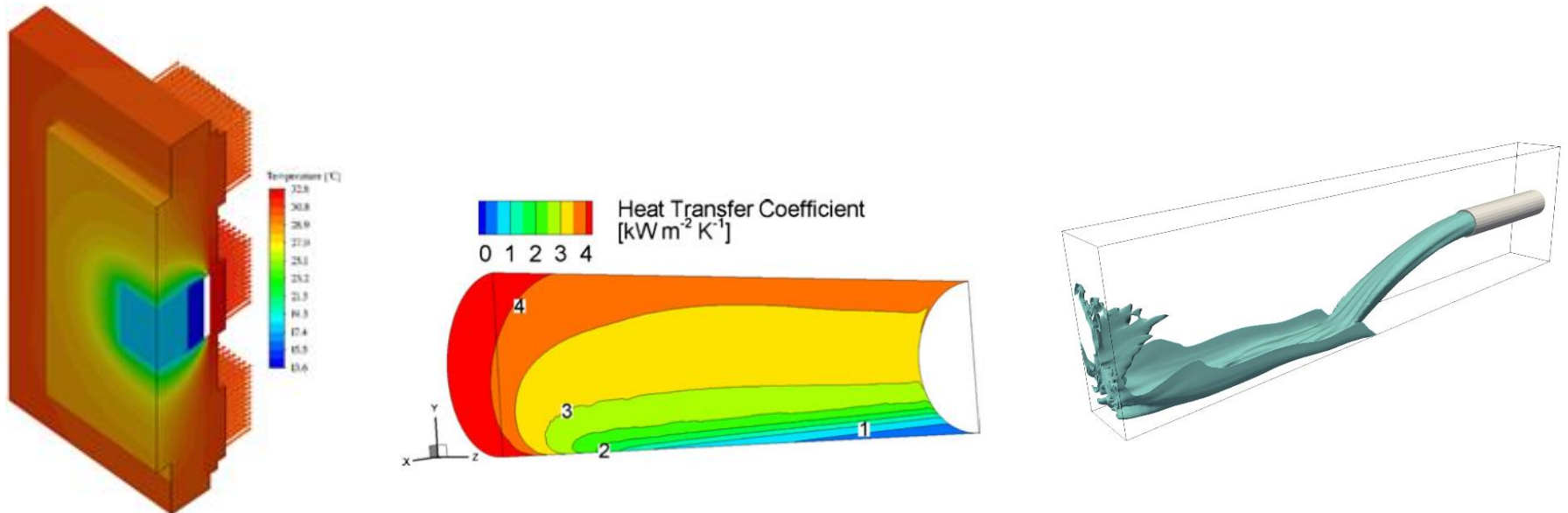

Laboratory of Applied Thermodynamics

GOALS: Knowledge of fundamentals of gas dynamics.

METHODS: lessons (18 hours), exercises (6 hours).

CONTENTS: One-dimensional gas dynamics: sonic velocity, Mach number, isentropic flow in varying-area channels, subsonic and supersonic nozzles and diffusers, normal and oblique shocks, adiabatic flow with friction in constant area ducts, flow with heat transfer in constant area ducts (18 hours).

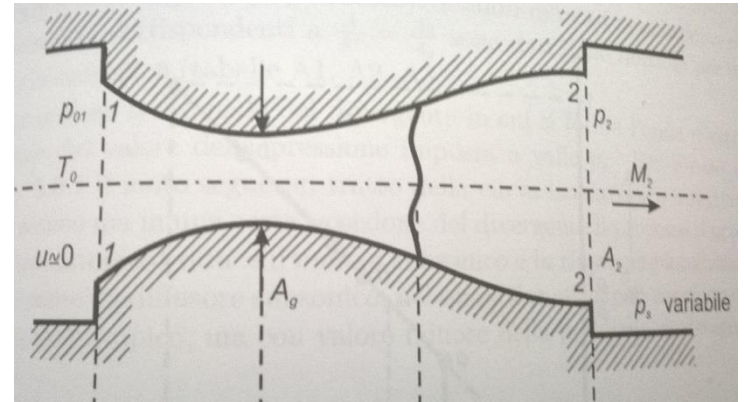

Laboratory of Energy Audit

GOALS: provide a systematic procedure for energy auditing suitable for both commercial buildings and industrial facilities to improve the energy efficiency and decrease the energy bills.

METHODS: the course is organized in both theoretical and applied lectures, and in exercises, both energy calculation and economic analysis. Students will develop a project exercise concerning the complete energy diagnosis of a large building.

CONTENTS:

Classification and characterization of energy services: heating, cooling, ventilation, production of domestic hot water, lighting and transport of people and things. Insights into the calculation of energy performance according to international Standards; use of inverse models and model calibration procedures; data retrieval methods, survey procedures, and data cataloging.

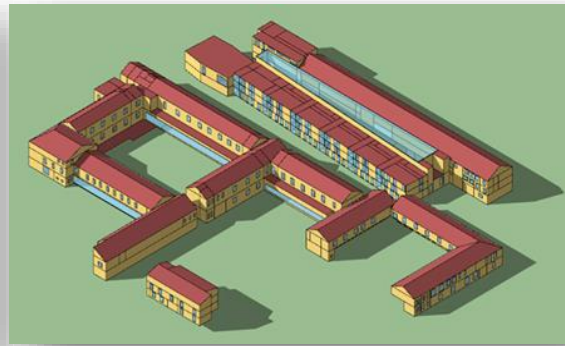

Master's degree Energy engineering



UNIVERSITÀ
DEGLI STUDI
DI PADOVA

MASTER'S DEGREE
Energy Engineering

Thank you for your attention !