

6 Radiators

D. G. Gilmore*

Introduction

Spacecraft waste heat is ultimately rejected to space by radiator surfaces. Radiators occur in several different forms, such as spacecraft structural panels, flat-plate radiators mounted to the side of the spacecraft, and panels deployed after the spacecraft is on orbit. Whatever the configuration, all radiators reject heat by infrared (IR) radiation from their surfaces. The radiating power depends on the surface's emittance and temperature. The radiator must reject both the spacecraft waste heat plus any radiant-heat loads from the environment or other spacecraft surfaces that are absorbed by the radiator, as shown in Fig. 6.1. Most radiators are therefore given surface finishes with high IR emittance ($\epsilon > 0.8$) to maximize heat rejection and low solar absorptance ($\alpha < 0.2$) to limit heat loads from the sun. Typical finishes, discussed in more detail in Chapter 4, include quartz mirrors, silvered or aluminized Teflon, and white paint.

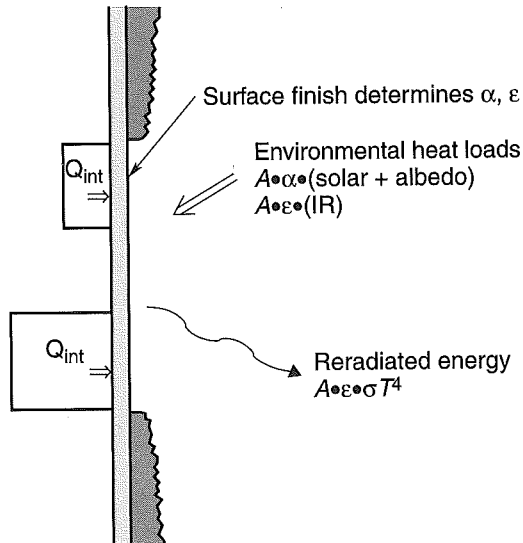

$$\text{Environmental loads} + \sum Q_{\text{int}} = \text{Reradiated energy}$$

(Steady state)

Fig. 6.1. (Fig. 4.1, reproduced here for your convenience.) Radiator energy balance. Environmental loads + $\sum Q_{\text{int}}$ = reradiated energy (steady state, no external blockage).

*The Aerospace Corporation, El Segundo, California.

The radiating power of a radiator is a strong function of temperature. The total heat leaving a radiator surface is given by the simple expression

$$\dot{Q} = A\epsilon\sigma T^4 \quad (6.1)$$

where A is surface area, ϵ is emittance, and σ is the Stefan-Boltzmann constant ($5.669 \times 10^{-8} \text{ W/m}^2 \cdot \text{K}^4$), and T is absolute temperature (K).

The T^4 term results in a large increase in radiating capability with temperature, as shown in Fig. 6.2. The radiating power at 50°C is about twice that at 0°C . At cryogenic temperatures the effect is even more pronounced, with a 70 K radiator having only 1/300th the heat-rejection capability of a room-temperature radiator. This characteristic makes cryogenic radiators extremely sensitive to environmental heating and heat leaks through insulation and supports, and it leads to special design considerations.

Most spacecraft radiators reject between 100 and 350 W of internally generated electronics waste heat per square meter. The upper end of this range is typical of a radiator that runs at a fairly high temperature (say 40°C) and experiences a relatively modest heat backload from the environment or other spacecraft surfaces. The lower end of the range might represent a radiator running below room temperature in low Earth orbit, where environmental backloads can be substantial. The actual sizing is determined by a thermal analysis that considers the desired operating temperature, worst-case satellite waste heat, environmental heating, and radiative and conductive interactions with other spacecraft surfaces. Weights for radiators typically vary from almost nothing, if an existing structural panel is used as a radiator, to around 12 kg/m^2 for a heavy deployable radiator and its support/deployment structure.

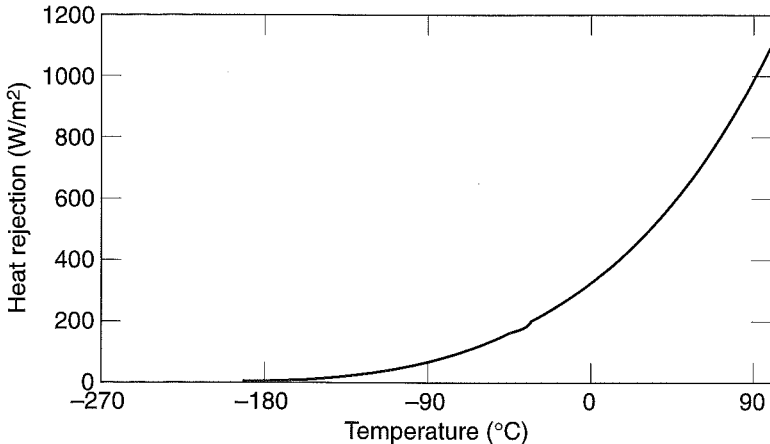

Fig. 6.2. Blackbody radiator heat rejection.

Passive Structure Radiators

The most common and simplest radiator is illustrated in Fig. 6.1. An existing aluminum honeycomb-panel wall of the spacecraft serves both as part of the structure and as a radiator, with its weight normally charged to the structures subsystem. The panel face-sheets spread heat out from the electronics boxes with an area on the outside face acting as the radiating surface. Heat is conducted fairly well from the inner to outer face sheets through the aluminum honeycomb core. Lateral heat conduction, however, occurs mainly in the face sheets. Appendix B includes equations for calculating the conductance of honeycomb cores in different directions.

Sometimes the face sheets are made thicker than required for structural reasons to help spread the heat out from the boxes and give a greater "fin efficiency." Separate plates of aluminum or other material may also be placed under high-power boxes to help spread the heat out on the panel. These plates are called "doublers" (see Chapter 8). Weights that result from increased face-sheet thickness or the use of doublers are generally charged to the thermal-control subsystem.

Structural Panels with Heat Pipes

If a honeycomb-panel radiator has mounted to it some electronics boxes that have high heat dissipation, then the lateral conduction in the face sheets may not be sufficient to spread the heat out over an area large enough to radiate it to space. This situation would result in very large temperature gradients in the panel and cause the high-power boxes to exceed their upper temperature limits. Doublers or increased face-sheet thickness may be used to overcome this problem; however, at a certain point these techniques will result in an unacceptably large weight increase.

To avoid this weight penalty, designers often use heat pipes to spread the heat. The results of one trade study comparing heat pipes to doublers on a communication satellite are shown in Fig. 6.3.

For an application with fairly constant heat loads, such as a panel of TWT amplifiers on a communication satellite, constant-conductance heat pipes may be used, as shown in Fig. 6.4. Variable-conductance heat pipes may be used in a situation with a wide variation in equipment or environmental heat loads, or a requirement to minimize cold-case heater power or to tightly control the temperature range of a component. A variable-conductance heat-pipe radiator panel is shown in Fig. 6.5. References 6.1, 6.2, and 6.3 discuss applications of fixed- and variable-conductance heat-pipe radiator panels on satellites.

Body-Mounted Radiators

Some applications require a radiator that is not part of the vehicle structure. The radiator may need to run at a temperature different from that of the rest of the spacecraft, or no vehicle structural panels may be convenient candidates for use as a radiator. In such situations a "body-mounted" radiator may be used. The radiator itself may be a honeycomb panel or a stiffened aluminum plate. Heat is transported from the heat-dissipating components to the radiator using fixed- or variable-conductance heat pipes, loop heat pipes, or capillary pumped loops, and additional heat pipes may be used to spread the heat out in the radiator panel itself.

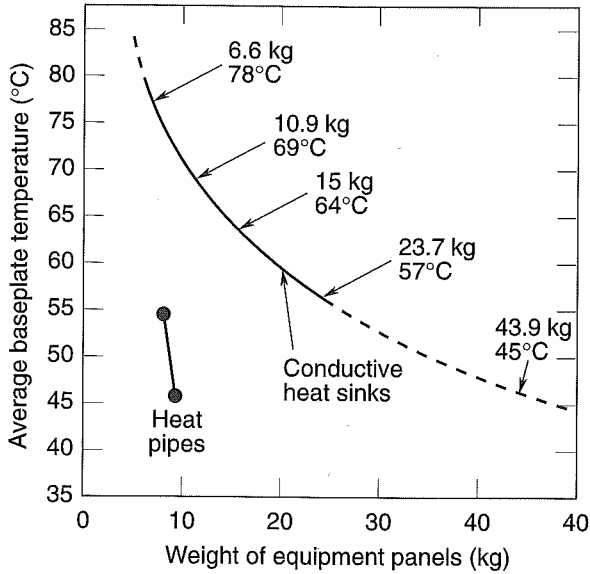

Fig. 6.3. Weight of conductive doublers versus heat pipes.

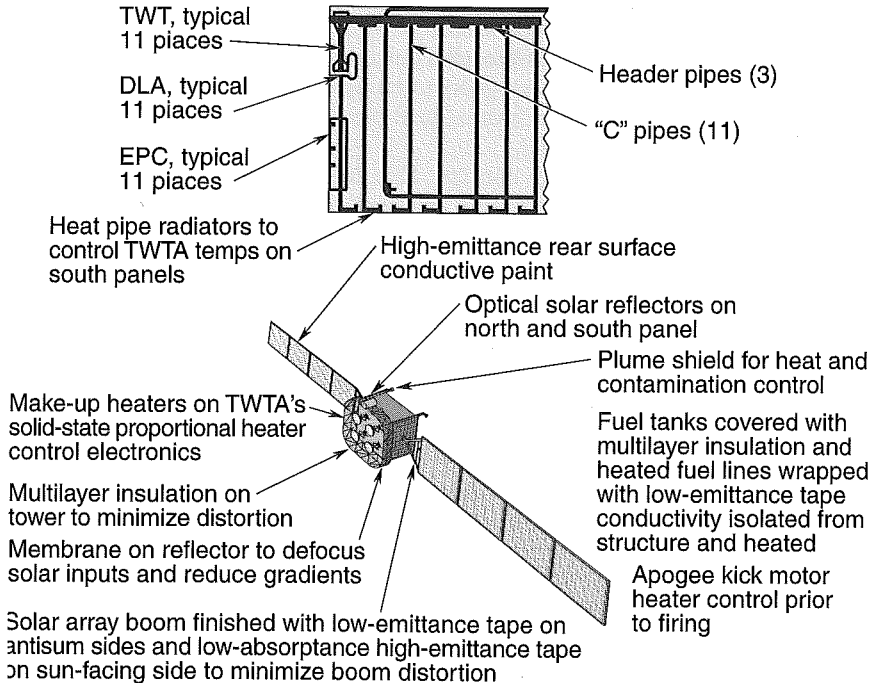

Fig. 6.4. Heat-pipe radiator panel.

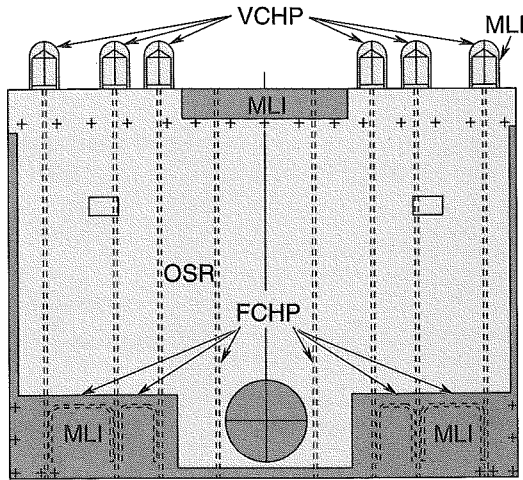

Fig. 6.5. Variable-conductance heat-pipe radiator.

Low-conductance mountings and multilayer insulation may be used to thermally isolate the radiator panel from the spacecraft. The body-mounted radiator used to reject waste heat from a cold plate on NASA's Earth Observing System AM spacecraft is shown in Fig. 6.6.

Deployable Radiators

At this time, most uncrewed spacecraft can reject internal waste heat using structural-panel or body-mounted radiators. However, as satellite power levels (and therefore waste heat) increase or as satellite size is reduced through the use of high-density electronics packaging, the satellite bus at some point simply lacks enough area to reject the internally generated waste heat. In such a situation, deployable radiators are sometimes required to increase the available radiating area.

An example of a deployable radiator is the Alpha Deployable Radiator manufactured by Swales Aerospace. As shown in Fig. 6.7, Alpha uses redundant-loop heat pipes (considered passive pumping devices) to transport heat across flexible joints to a two-sided, four-square-meter radiator panel. Alpha is designed to be attached to a spacecraft through spherical-bearing hinges, pyrotechnic or paraffin release actuators, and snubbers. It has a stated capacity of 1250 W at an evaporator temperature of 36°C. Design and performance details are shown in Table 6.1. Deployable radiators that replace the flexible joint used by Swales with condenser lines coiled around (or near) the deployment axis of rotation have been developed by other companies. These designs, however, are patent protected and therefore not freely available for use by others.

Lockheed Martin/Vought Systems has developed several deployable radiator systems for crewed spacecraft that use active, mechanically pumped fluid loops to transport heat. The largest of these radiators (Fig. 6.8) is for the International Space Station; it uses a pumped liquid ammonia loop to transport 16 kw out to each radiator assembly. A smaller version of this radiator is used to cool the Space Station

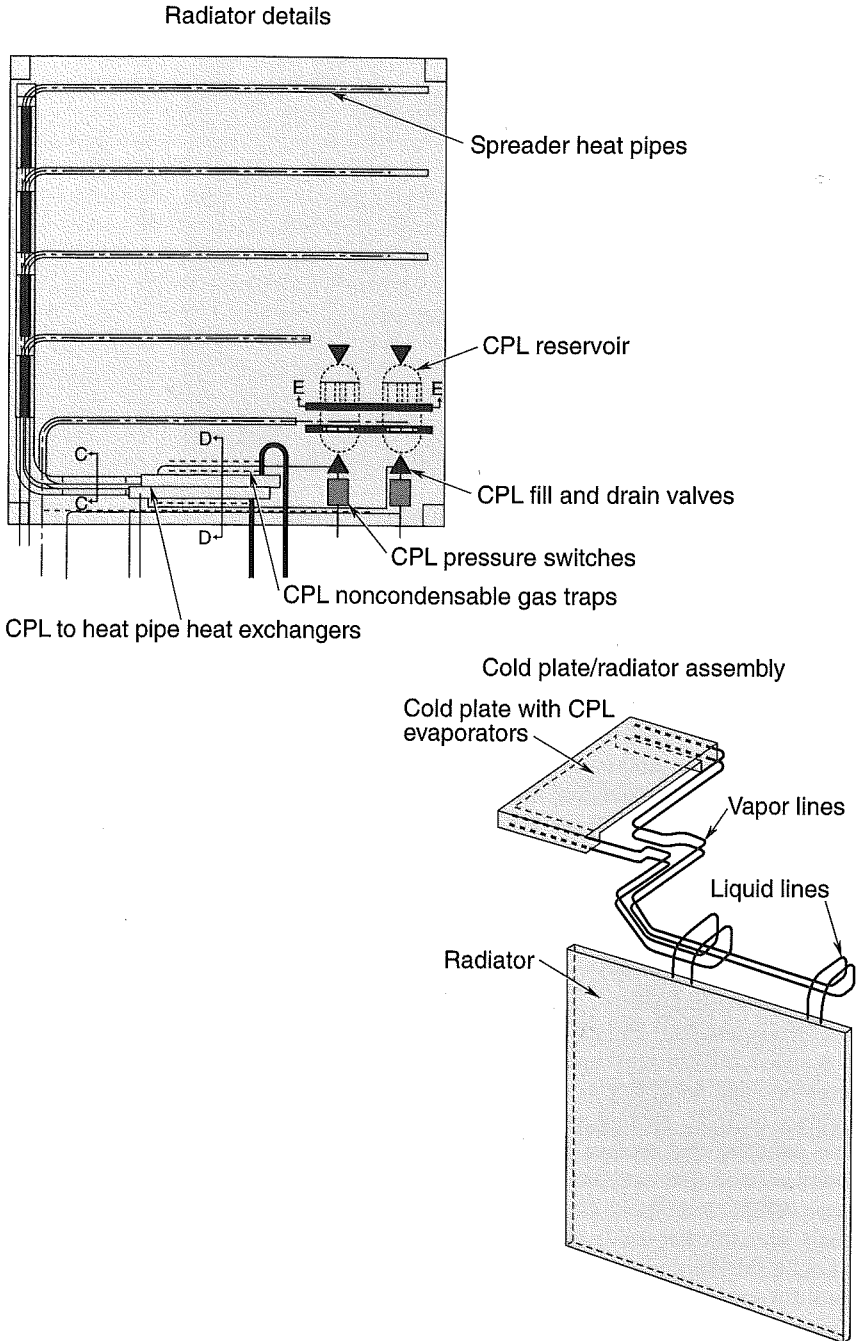

Fig. 6.6. Body-mounted radiator for Earth Observing System. (Courtesy of NASA)

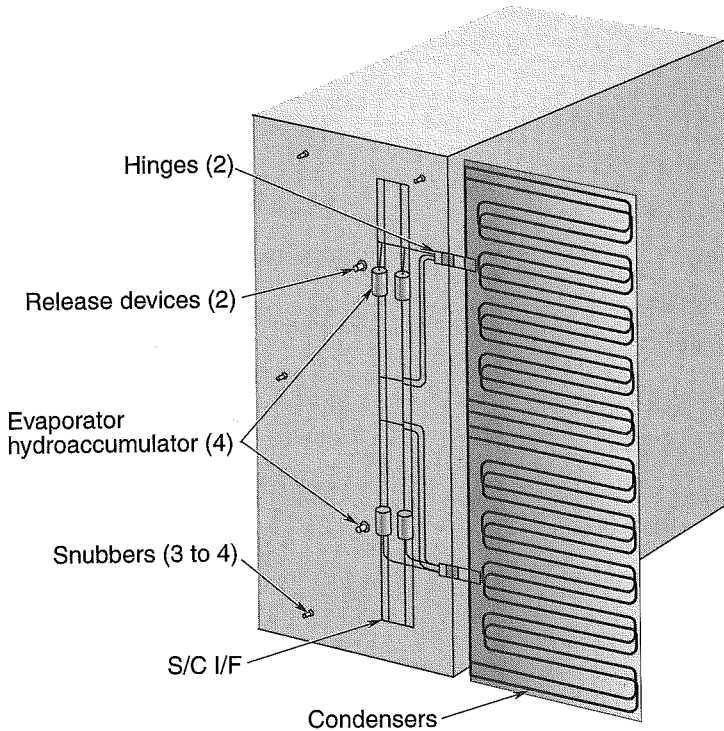

Fig. 6.7. Alpha Deployable Radiator. (Courtesy of Swales Aerospace)

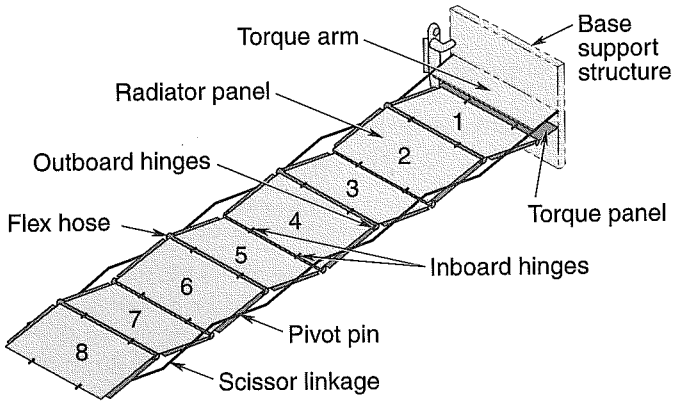

Fig. 6.8. Space Station deployable radiator.

electrical-power subsystem. The space shuttle uses Vought deployable radiators with a mechanically pumped freon heat-transport loop, as shown in Fig. 6.9. Further information on mechanically pumped fluid-loop cooling systems can be found in Chapter 12.

Table 6.1. Alpha Radiator Characteristics

Characteristic	Description
Radiator	
Heat-rejection capacity	1250 W
Size	1.27 m × 3.18 m
Coating	Silver Teflon or quartz mirrors
Loop heat pipes	
Number of LHPs	4
Single pipe capacity at 65°C	>600 W @ 1 m adverse tilt
Evaporator length	457 mm
Condenser type	Direct condensation serial
Ground test elevation	>1 m with 1 failed LHP
Mechanisms	
Flex lines	Flex hose, 6.4 mm ID
Release device	G&H NEA
Hinge	Spherical bearing, torsion spring
Mass	
LHPs	9.5 kg
Radiator	10.2 kg w/silver Teflon, 11.3 kg w/quartz mirrors
Mechanisms	2.0 kg
Total	21.7 to 22.8 kg
Specific heat rejection	57.6 to 54.8 W/kg

Almost all radiators using mechanically pumped fluid loops to date were developed for crewed systems that either have short mission durations (e.g., the space shuttle) or are massively redundant and serviceable by astronauts (e.g., the Space Station; it has six main radiator assemblies). Uncrewed spacecraft, however, are usually designed for long-duration missions with no servicing. Pumped fluid loops have generally been a concern for such missions because of the potential for failure of mechanical pumps. This situation has recently begun to change with the use of pumped loops on the JPL Mars Pathfinder and Mars Exploration Rover programs. As the power levels of uncrewed spacecraft continue to rise, mechanically pumped loop cooling systems may at some point demonstrate a significant weight advantage over competing passive (heat-pipe) systems. Therefore, if the

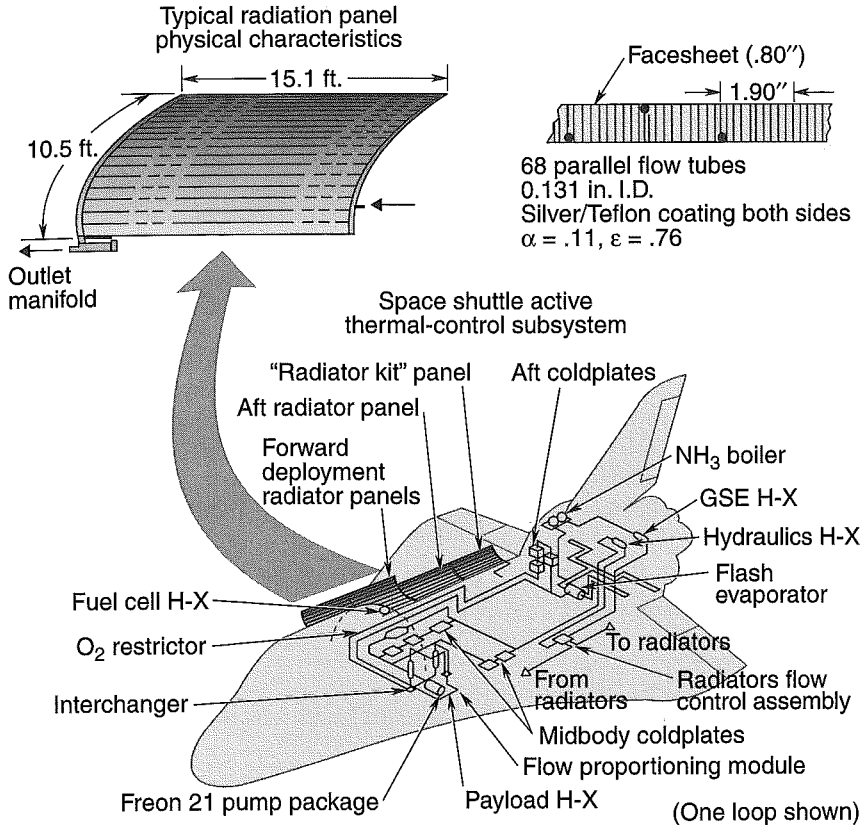

Fig. 6.9. Space shuttle active cooling system.

mechanical pumps can demonstrate sufficient reliability, pumped-loop radiator systems may become more common on uncrewed spacecraft in the future.

Radiator Freezing

Every spacecraft that uses radiators with passively or actively pumped fluid loops must address the issue of potential damage resulting from the freezing, and subsequent thawing, of fluids during cold-case operating or safe-mode conditions. Unlike water, most fluids expand when they melt. If a section of frozen coolant line melts, the liquid may be trapped between two frozen sections, resulting in a large local pressure buildup that can burst the line. This failure mechanism has caused the rupture of coolant loops during ground testing and propellant lines on orbiting spacecraft and therefore must be seriously considered in the design of radiators.

Because deployable radiators have a large area and low mass, and they are completely exposed to the environment, they are particularly susceptible to freezing

under cold-case conditions. Analysis of the deployable Space Station radiators shown in Fig. 6.8 and described in Table 6.2 indicated that the ammonia coolant lines in the radiator panels could drop to -94°C , well below the -77°C freezing point of ammonia. Further testing showed that local thawing of a line produced internal pressures as high as $2.96 \times 10^8 \text{ N/m}^2$, which was beyond the yield stress of the stainless-steel radiator tubes.

The Space Station program investigated several options to prevent freezing, including preheating the radiators before eclipses, using beryllium or lithium instead of aluminum or packing the radiator with phase-change material to increase thermal capacitance, and using heaters or radiator retraction during cold conditions. After reviewing these and other options, NASA decided that the most reliable and cost-effective solution was to design the radiator to freeze without damage or operational impacts. This alternative eliminated the need for active monitoring of the environment and other costly schemes to avoid freezing. Damage resulting from local thawing of a frozen line was prevented by changing the tube material from 321 stainless steel, with a yield stress of $2.06 \times 10^8 \text{ N/m}^2$, to inconel, with a yield stress of $1.20 \times 10^9 \text{ N/m}^2$. Varying the spacing of the tubes in each radiator panel, as shown in Fig. 6.10, allows tubes with larger radiating area

Table 6.2. Heat Rejection System (HRS)

HRS Fact Sheet	
Purpose	
• Cools Space Station crew, subsystems, and experiment heat loads	
Programmatics	
• Customer: McDonnell Douglas Space Systems Company/NASA-JSC	
• Contract duration: 5/91–1/98	
Deliverables	
• 3 dev. panels	• 1 qual. unit
• 1 qual. burst panel	• 6 flight units
• 1 full-scale engr. proto	• 9 shipping containers
Characteristics	
• Each unit consists of 8 panels, $9' \times 11'$	
• Deployed by scissors mechanism	
• 75' deployed length	
• 2200 lbs per unit	
• Two cooling temperatures:	
-2°C units: 11 kW cooling each	
$+11^{\circ}\text{C}$ units: 16 kW cooling each	
• Condensing ammonia two-phase cooling fluid	
• Bonded honeycomb panel construction	
• White ceramic thermal paint	

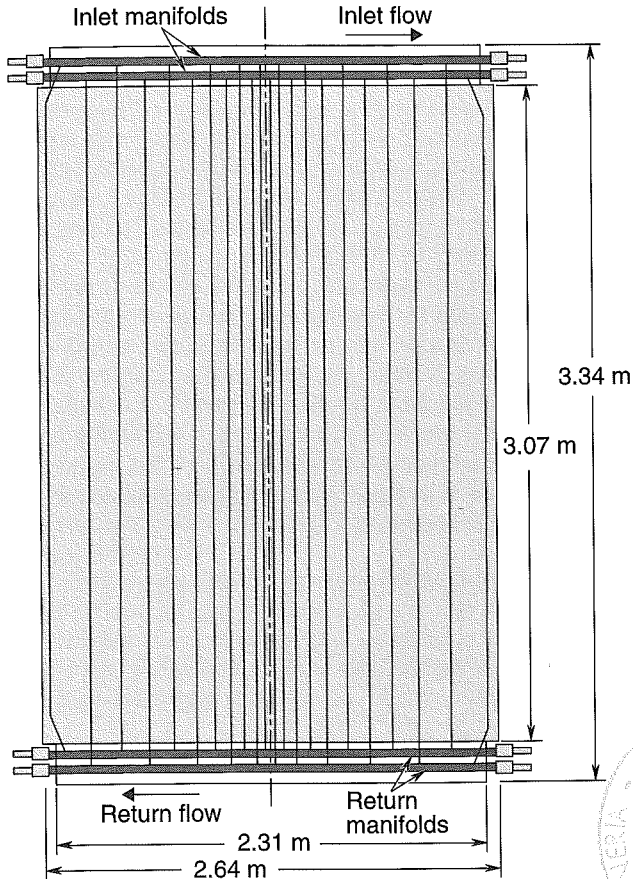

Fig. 6.10. Freeze-tolerant radiator design.

to freeze first, forcing more warm ammonia to flow through the more closely spaced tubes that have less radiating area. This scheme prevents complete freezing of the radiator even under worst cold-case conditions.

Radiator Effectiveness

In the design of a radiator employing parallel heat pipes or coolant tubes, the engineer must determine the spacing of the pipes or tubes and the thickness of the fins. The smallest radiator area would be achieved if one were to use very thick fins and close pipe spacing for maximum fin efficiency. Despite its small size, however, such a radiator would be very heavy because of the large number of pipes and the thick fins. Since weight is usually the critical driver for satellite development, a somewhat less-efficient, but lighter, radiator may be preferred.

For any radiator, one may determine an optimum combination of heat-pipe spacing and fin thickness, to find the minimum total radiator weight. The generalized heat-balance equation for a fin radiating to an effective sink temperature T_s is:

$$\frac{d^2T}{dx^2} - \frac{(t_B - t_T)}{Lt_T + (t_B - t_T)(L - x)} \frac{dT}{dx} - \frac{\sigma \left(\frac{\epsilon_1}{\cos \beta_1} + \frac{\epsilon_2}{\cos \beta_2} \right) L}{2K[Lt_T + (t_B - t_T)(L - x)]} (T^4 - T_s^4) = 0 \quad (6.2)$$

and the boundary conditions to be satisfied are:

$$T|_{x=0} = T_B \quad (6.3)$$

$$\left. \frac{dT}{dx} \right|_{x=L} = 0 \quad (6.4)$$

(see Fig. 6.11 for an illustration of the parameters). This equation was solved numerically by Chang (Ref. 6.4) to derive the following expression for fin effectiveness for a fin of uniform thickness:

$$\eta_e = (1 - 1.125\zeta + 1.60\zeta^2)(1 - \theta^{*4}) \quad 0.01 \leq \zeta \leq 0.2 \quad (6.5)$$

$$= (-0.405 \log \zeta + 0.532)(1 - \theta^{*4}) \quad 0.2 \leq \zeta \leq 2.0 \quad (6.6)$$

$$\zeta = \frac{\sigma L^2 T^3 B (\epsilon_1 + \epsilon_2)}{kt} \quad (6.7)$$

$$\theta^* = \frac{T_s}{T_B} \quad (6.8)$$

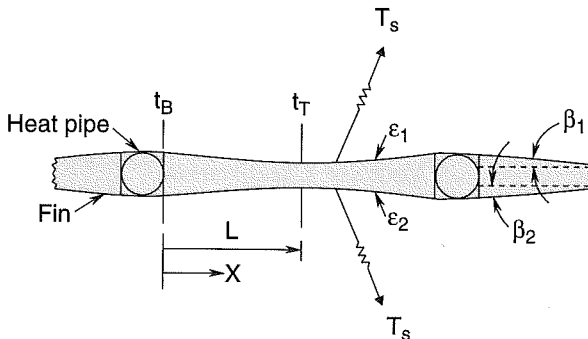

Fig. 6.11. Radiator analysis terminology and variables.

where ε_1 and ε_2 are the radiator emittance of side 1 and side 2, L is heat-pipe spacing divided by 2, T_B is temperature at fin base, T_S is radiative sink temperature, σ is the Stefan-Boltzmann constant, k is fin conductivity, and t is fin thickness.

It is important to note that this expression for fin effectiveness is not the same as the usual definition of fin efficiency. Here it is the ratio of the net heat rejected by the fin to the heat that would be rejected by an isothermal fin to a 0 K sink. This definition of effectiveness therefore accounts for the thermal backload to the fin from the sink as well as the efficiency of the fin itself. The heat rejected from the radiator is therefore calculated as $Q = A\varepsilon\eta_e\sigma T_B^4$ instead of the usual $Q = A\varepsilon\eta_e\sigma(T_B^4 - T_S^4)$.

Equation (6.5) or (6.6) can be used to calculate the effectiveness of the radiator for various combinations of heat-pipe spacing (L) and fin thickness (t). Once the effectiveness is known, the total area required to radiate the satellite waste heat, and the resultant weights of heat pipe, fin material, and radiator optical coating, can be easily calculated. Figure 6.12 shows the results of such an analysis for a two-sided flat-aluminum-heat-pipe radiator rejecting 1000 W at 21°C to an effective sink temperature of -87°C. (The effective sink temperature accounts for the backloads on the radiator caused by environmental heating and radiative interchange with other spacecraft surfaces.) The heat pipes were assumed to weigh 0.11 kg per linear meter.

The minimum radiator weight occurs for a fin thickness of approximately 0.18 mm, a heat-pipe spacing of approximately 20 cm, and an overall fin effectiveness of only 0.5. If thicker fins and closer pipe-spacing is used, the fin effectiveness increases and the size goes down, but the total weight is much greater. If 0.51 mm fins and 10 cm pipe-spacing is used, the fin effectiveness increases to 0.78 and the

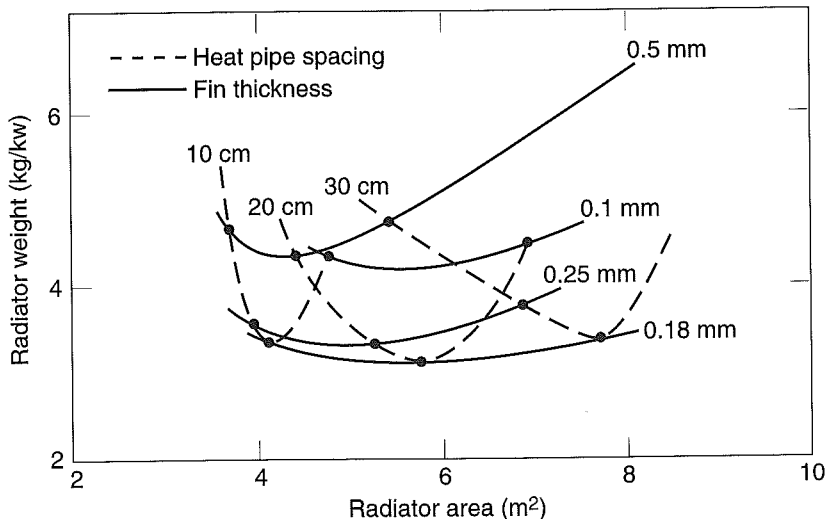

Fig. 6.12. Radiator analysis results.

size is reduced by 36%, but the weight increases by 50%. The actual total weight of the radiator must, of course, include any support structure and, for a deployable radiator, deployment-mechanism weight. The minimum fin thickness may also, in some designs, be driven by structural considerations. The above calculation does, however, illustrate the fact that maximum fin efficiency does not give a minimum radiator weight.

Experimental Radiators

A number of more exotic radiator technologies have been studied, including flexible, moving-belt, and liquid-droplet radiators. The flexible radiator shown in Fig. 6.13 can be conveniently stowed in a small volume. The moving-belt radiator in Fig. 6.14 transports heat by moving the radiator surface and thereby eliminates the need for heat pipes or fluid loops in the radiator itself. Liquid-droplet or liquid-sheet radiators, shown in Fig. 6.15, eliminate the radiator fin and tubes entirely, and radiate heat directly from a low-vapor-pressure fluid that is sprayed out into space and then collected and recirculated. The use of heat pumps to boost the radiating temperature of any radiator and thereby reduce its size has also been studied. More information on each of these experimental technologies can be found in Refs. 5 through 12.

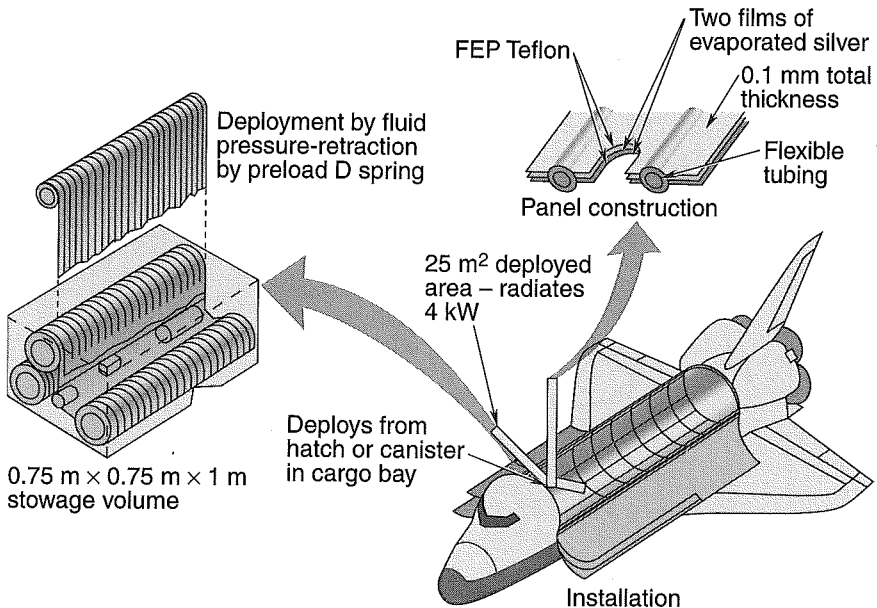

Fig. 6.13. Flexible radiator system.

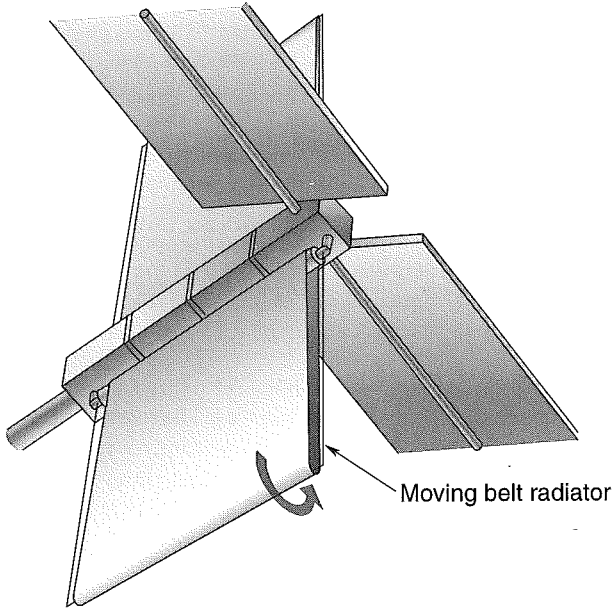

Fig. 6.14. Moving-belt radiator.

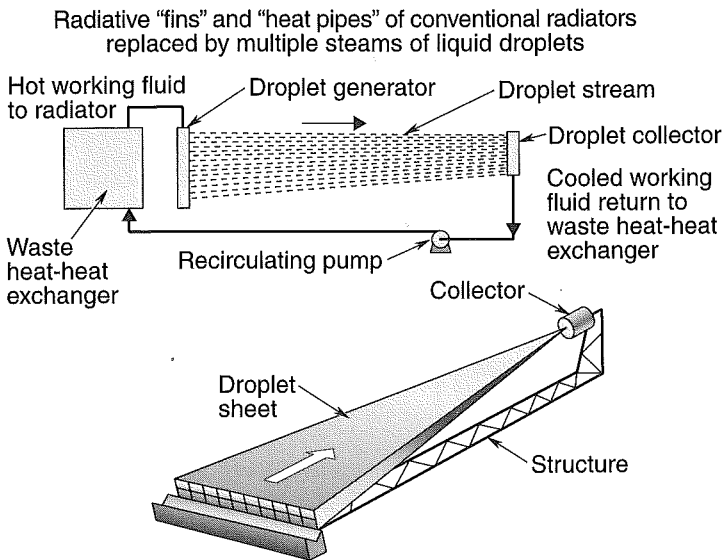

Fig. 6.15. Liquid-droplet radiator.

References

- 6.1. P. C. Wise, J. Raisch, W. Kelly, and S. P. Sharma, "Thermal Design Verification of a High Power Direct Broadcast Satellite," AIAA-86-1339, June 1986.
- 6.2. P. Joy and L. Goliaszewski, "Advanced Thermal and Power Systems for the Satcom-Ku Satellites," AIAA-86-0618, June 1986.
- 6.3. H. Masumoto *et al.*, "Development of a VCHP/FCHP Radiator System for 3-Axis Stabilized Geostationary Satellite Application," AIAA-85-1012, June 1985.
- 6.4. H. V. Chang, "Optimization of a Heat Pipe Radiator Design," AIAA-84-1718, June 1984.
- 6.5. R. L. Cox and J. W. Leach, "Flexible Deployable - Retractable Space Radiators," AIAA-77-764 June 1977.
- 6.6. P. F. Dexter and W. L. Haskin, "Analysis of Heat Pump Augmented Systems for Spacecraft Thermal Control," AIAA-84-1757, June 1984.
- 6.7. B. Drolen, "Heat-Pump Augmented Radiator for High Power Spacecraft Thermal Control," AIAA-89, January 1989.
- 6.8. K. A. White, R. Ponnappan, J. E. Beam, and E. T. Mahefkey, "Conceptual Design of a 1 m Long 'Roll Out Fin' Type Expandable Space Radiator," AIAA-86-1323, June 1986.
- 6.9. K. A. White, "Liquid Droplet Radiator Development Status," AIAA-87-1537, June 1987.
- 6.10. D. L. Chubb and K. A. White, "Liquid Sheet Radiator," AIAA-87-1525, June 1987.
- 6.11. A. F. Presler *et al.*, "Liquid Droplet Radiator Program at the NASA Lewis Research Center," ASME 86-HT-15, June 1986.
- 6.12. Lt. J. Feig, "Radiator Concepts for High Power Systems in Space," AIAA-84-0055, January 1984.