

Thermal Comfort



This booklet is an introduction to thermal comfort. It explains procedures to evaluate the thermal environment and methods applied for its measurement.

Contents

[What is Thermal Comfort?](#)

[How is Body Temperature regulated?](#)

[How does man evaluate the Thermal Environment?](#)

[First conditions for Thermal Comfort](#)

[The Comfort Equation](#)

[Metabolic Rate estimation](#)

[Clo value calculations](#)

[What should be measured?](#)

[What is Mean Radiant Temperature and how to measure it?](#)

[What are Operative, Equivalent and Effective Temperatures?](#)

[Operative and Equivalent Temperature can be measured directly](#)

[How to create Thermal Comfort](#)

[The PMV and PPD scales](#)

[Local Thermal Discomfort](#)

[Draught](#)

[Evaluating the Draught Rate](#)

[Asymmetry of Thermal Radiation](#)

[Vertical Air Temperature Difference](#)

[Floor Temperature](#)

[How to perform a measurement in a workplace](#)

[How to evaluate the Thermal Quality of a room](#)

[Further Reading](#)

Appendices:

[A: Dry Heat Loss calculations](#)

[B: Heat Balance, Comfort and PMV equations](#)

[C: Met value table](#)

[D: Clo value table](#)

[E: Calculation of Mean Radiant Temperature](#)

[F: Calculation of Plane Radiant and Operative Temperature.](#)

[Nomenclature](#)

▲ What is Thermal Comfort?

Man has always striven to create a thermally comfortable environment. This is reflected in building traditions around the world - from ancient history to present day. Today, creating a thermally comfortable environment is still one of the most important parameters to be considered when designing buildings.

But what exactly is Thermal Comfort? It is defined in the ISO 7730 standard as being "That condition of mind which expresses satisfaction with the thermal environment". A definition most people can agree on, but also a definition which is not easily converted into physical parameters.

The complexity of evaluating thermal comfort is illustrated by the drawing. Both persons illustrated are likely to be thermally comfortable, even though they are in completely different thermal environments. This reminds us that thermal comfort is a matter of many physical parameters, and not just one, as for example the air temperature.

Thermal environments are considered together with other factors such as air quality, light and noise level, when we evaluate our working environment. If we do not feel the everyday working environment is satisfactory, our working performance will inevitably suffer. Thus, thermal comfort also has an impact on our work efficiency.



▲ How is Body Temperature regulated?

Man has a very effective temperature regulatory system, which ensures that the body's core temperature is kept at approximately 37°C.

When the body becomes too warm, two processes are initiated: first the blood vessels vasodilate, increasing the blood flow through the skin and subsequently one begins to sweat. Sweating is an effective cooling tool, because the energy required for the sweat to evaporate is taken from the skin. Only a few tenths of a degrees increase in the core body temperature can stimulate a sweat

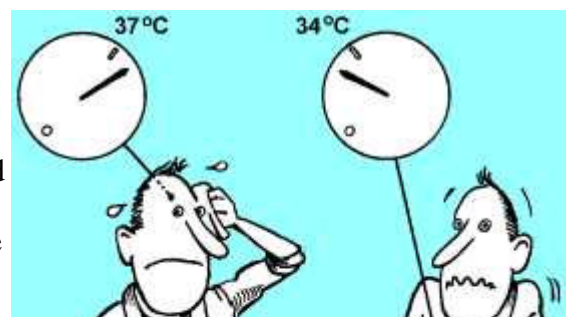

production which quadruples the body's heat loss.

If the body is getting too cold, the first reaction is for the blood vessels to vasoconstrict, reducing the blood flow through the skin. The second reaction is to increase the internal heat production by stimulating the muscles, which causes shivering. This system is also very effective, and it can increase the body's heat production dramatically.

The control system which regulates the body temperature is complex, and is not yet fully understood. The two most important set of sensors for the control system are however known. They are located in the skin and in the hypothalamus. The hypothalamus-sensor is a heat sensor which starts the body's cooling function when the body's core temperature exceeds 37° C. The skin-sensors are cold sensors which start the body's defence against cooling down when the skin temperature falls below 34°C.

If the hot and cold sensors output signals at the same time, our brain will inhibit one or both of the body's defence reactions.

▲ How does man evaluate the Thermal Environment?

Man considers the environment comfortable if no type of thermal discomfort is present. The first comfort condition is thermal neutrality, which means that a person feels neither too warm nor too cold.

When the skin temperature falls below 34°C, our cold sensors begin to send impulses to the brain; and as the temperature continues to fall, the impulses increase in number. The number of impulses are also a function of how quickly the skin temperature falls - rapid temperature drops result in many impulses being sent.

Similarly, the heat sensor in the hypothalamus sends impulses when the temperature exceeds 37°C, and as the temperature increases, the number of impulses increase. It is believed that it is the signals from these two sensor systems that form the basis for our evaluation of the thermal environment.

The brain's interpretation of the signals is assumed to be like a tug-of-war, with the cold impulses at one end of the rope and the warm impulses at the other. If the signals on both sides are of the same magnitude, you feel thermally neutral, if not, you either feel too warm or too cold. A person in a thermally neutral state and completely relaxed makes for a special case, as he will activate neither the heat or cold sensors.

It takes some time to change the body's core temperature; the signal from the heat sensor therefore change very slowly compared to the signals from the cold sensors.

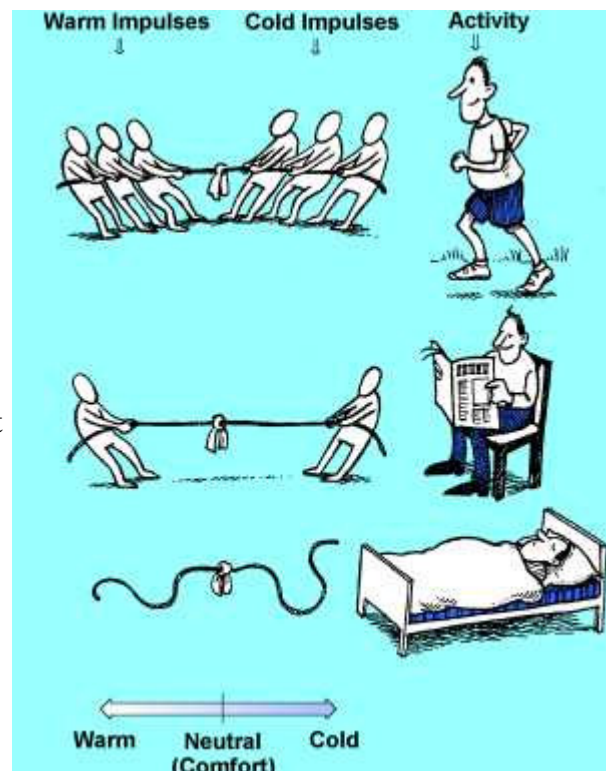

▲ First conditions for Thermal Comfort

Two conditions must be fulfilled to maintain thermal comfort. One is that the actual combination of skin temperature and the body's core temperature provide a sensation of thermal neutrality. The second is the fulfilment of the body's energy balance: the heat produced by the metabolism should be equal to the amount of heat lost from the body. The relationship between the parameters: skin temperature, core body temperature and activity, which result in a thermally neutral sensation, is based on a large number of experiments. During these experiments the body's core temperature, the skin temperature and the amount of sweat produced were measured at various known levels of activity, while the testpersons were thermally comfortable. The results of the experiments can be seen in the figure.

Sweat production was chosen as a parameter instead of the core body temperature, but as the sweat production is a function of the deep body and skin temperature this does not in principle change anything in the thermal sensation model.

No differences between sexes, ages, race and national-geographic origin were observed in the above experiment, when determining: What is a thermally comfortably environment? However, differences was observed between individuals on the same matter.

The equations controlling the energy balance for a person are relatively simple. They can be seen in Appendix B.

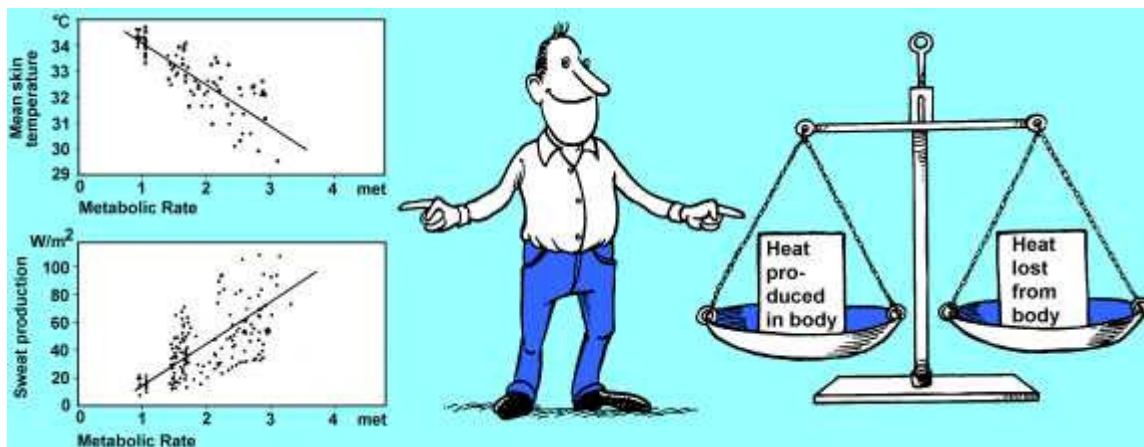

▲ The Comfort Equation

The equation for comfortable skin temperature and sweat production can be combined with the equation for the body's energy balance to derive the Comfort Equation. This equation describes the connection between the measurable physical parameters and thermally neutral sensation as experienced by the "average" person.

The comfort equation provides us with an operational tool which by measuring physical parameters enables us to evaluate under which

Comfort Equation:

$$M - W = H + E_c + C_{res} + E_{res}$$

$$E_c = 3.05 \cdot 10^{-3} \cdot [5733 - 6.99 \cdot (M - W - P_a)] + 0.42 \cdot (M - W - 58.15)$$

$$C_{res} = 0.0014 \cdot M \cdot (34 - t_a)$$

$$E_{res} = 1.72 \cdot 10^{-5} \cdot M \cdot (5867 - P_a)$$

H is either measured directly or calculated from the equation in Appendix A.

conditions thermal comfort may be offered in a workplace. The Comfort Equation derived by P.O. Fanger /1/ is too complicated for manual arithmetic and is normally solved using a computer. The full equation can be seen in Appendix A and Appendix B.

The equation reveals that the temperature of the surfaces in the enclosure where a person is has a huge influence on thermal sensation. A 1°C change in surface temperature may under many circumstances have as large an influence on a persons thermal sensation as a change of 1°C in the air temperature. Furthermore, the comfort equation reveals that the humidity level only has a moderate influence on the thermal sensation.

In practise, it is important to know which input parameters the Comfort Equation requires. These are:

- 2 table values giving the persons activity and clothing levels. (Clo and Met values).
- 2-4 measured parameters describing the thermal environment in the workplace.

Metabolic Rate estimation

The metabolism is the body's motor, and the amount of energy released by the metabolism is dependent on the amount of muscular activity. Normally, all muscle activity is converted to heat in the body, but during hard physical work this ratio may drop to 75%. If, for example, one went up a mountain, part of the energy used is stored in the body in the form of potential energy.

Traditionally, metabolism is measured in Met (1 Met = 58.15 W /m² of body surface). A normal adult has a surface area of 1.7 m², and a person in thermal comfort with an activity level of 1 Met will thus have a heat loss of approximately 100W. Our metabolism is at its lowest while we sleep (0.8 Met) and at its highest during sports activities, where 10 Met is frequently reached. A few examples of metabolic rates for different activities are shown in the diagram. In addition to this, there is a metabolic rate table in Appendix C.

A Met rate commonly used is 1.2, corresponding to normal work when sitting in an office. It is interesting to see that domestic work is relative hard work with Met values of 2.5 and 2.9.

When evaluating the metabolic rate of an individual, it is important to use an average value for the activities the person has performed within the last hour. The reason for this is that the body's heat capacity makes it "remember" approximately one hour of activity level.

Clo value calculations

Clothing reduces the body's heat loss. Therefore, clothing is classified according to its insulation value. The unit normally used for measuring clothing's insulation is the Clo unit, but the more technical unit m²°C/W is also seen frequently (1 Clo = 0.155 m²°C/W).

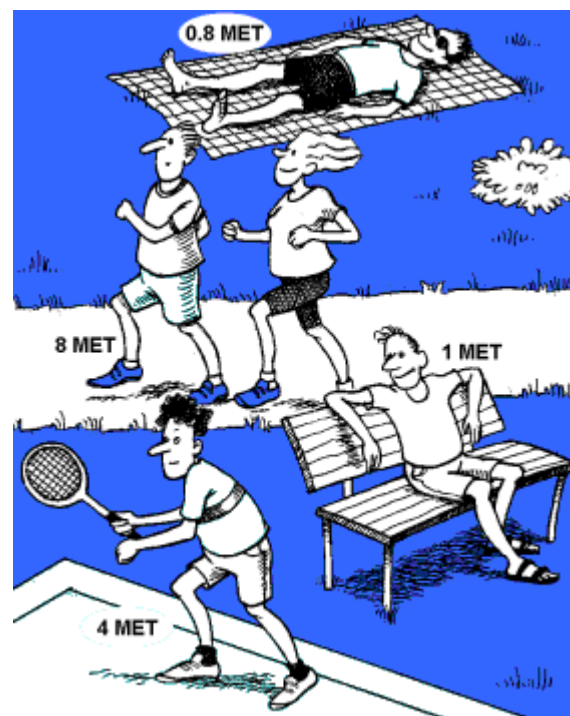

The Clo scale is designed so that a naked person has a Clo value of 0.0 and someone wearing a typical business suit has a Clo value of 1.0. Some normal Clo values are shown in the figure. The Clo value can be calculated if the persons dress and the Clo values for the individual garments are known, by simply adding the

Clo values together. Appendix D contains a list of clothing items and their corresponding Clo values.

Obtaining the Clo value through calculation normally gives a sufficient accuracy. If exact values are required, it is better to measure the Clo value using a heated mannequin dummy.

When calculating Clo values, it is important to remember that upholstered seats, car seats and beds reduce the heat loss from the body too, and therefore, these must be included in the overall calculation.

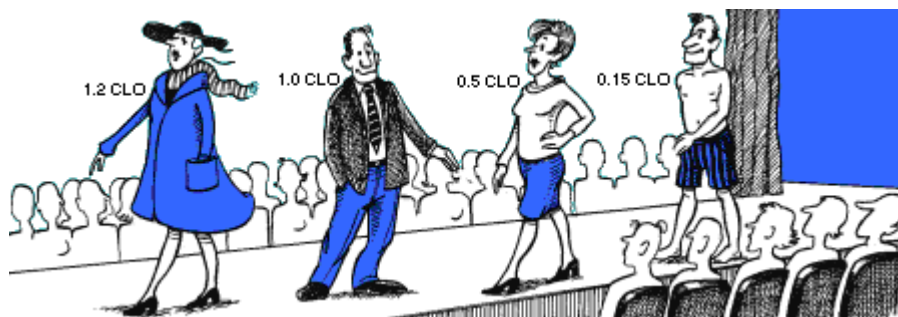

▲ What should be measured?

When measuring the thermal indoor climate, it is important to remember that man does not feel the room temperature, he feels the energy loss from the body. The parameters that must be measured are those which affect energy loss. These are:

t_a	Air Temperature	[°C]
\bar{t}_r	Mean Radiant Temperature	[°C]
v_a	Air Velocity	[m/s]
p_a	Humidity	[Pa]

The influence of these parameters on energy loss are not equal, but it is not sufficient to measure only one of them. For example, Mean Radiant Temperature frequently has as great an influence as the air temperature on the energy loss.

To characterise thermal indoor climate using fewer parameters and to avoid measuring the mean radiant temperature, which is difficult and time consuming to obtain, some integrating parameters have been introduced. The 3 most important are the Operative Temperature (t_o), the Equivalent Temperature (t_{eq}) and the Effective Temperature (ET^*).

The integrating parameters combine the influence on the heat loss of the single parameters as follows:

t_o	integrated effect of	$t_a + \bar{t}_r$
t_{eq}	integrated effect of	$t_a + \bar{t}_r + v_a$
ET^*	integrated effect of	$t_a + \bar{t}_r + p_a$

The integrating parameter offers us the convenience of describing the thermal environment in fewer numbers.

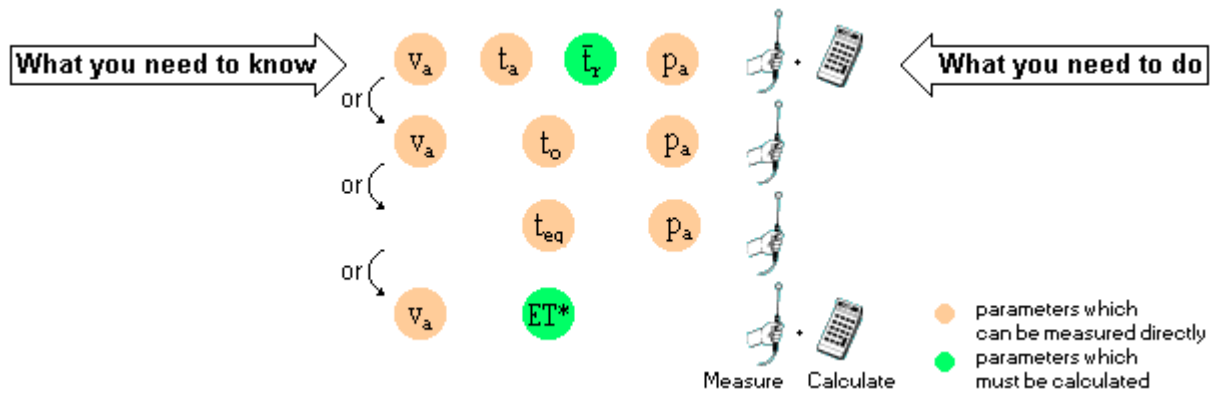

What is Mean Radiant Temperature and how to measure it?

The Mean Radiant Temperature of an environment is defined as that uniform temperature of an imaginary black enclosure which would result in the same heat loss by radiation from the person as the actual enclosure.

The equation for the calculation of Mean Radiant Temperature is:

$$\bar{t}_r = \sqrt[4]{\frac{\sum_{p-i} F_{p-i} (t_i + 273)^4}{n}} - 273$$

t_i Surface temperature of surface i [$^{\circ}\text{C}$]
 F_{p-i} Angle factor between the person and surface i $\sum F_{p-i} = 1$

Measuring the temperature of all surfaces in the room is very time consuming, and even more time consuming is the calculation of the corresponding angle factors. That is why the use of the Mean Radiant Temperature is avoided if possible.

The Globe Temperature, the Air Temperature and the Air Velocity at a point can be used as input for a Mean Radiant Temperature calculation. The quality of the result is, however, doubtful, partly because the angle factors between the globe and the surfaces in a room are different from those between a person and the same surfaces, and partly due to the uncertainty of the convective heat transfer coefficient for the globe.

Use of the Globe Temperature for calculation of Mean Radiant Temperature and a procedure for calculation of Mean Radiant Temperature on the basis of Plane Radiant Temperatures can be seen in Appendix E.

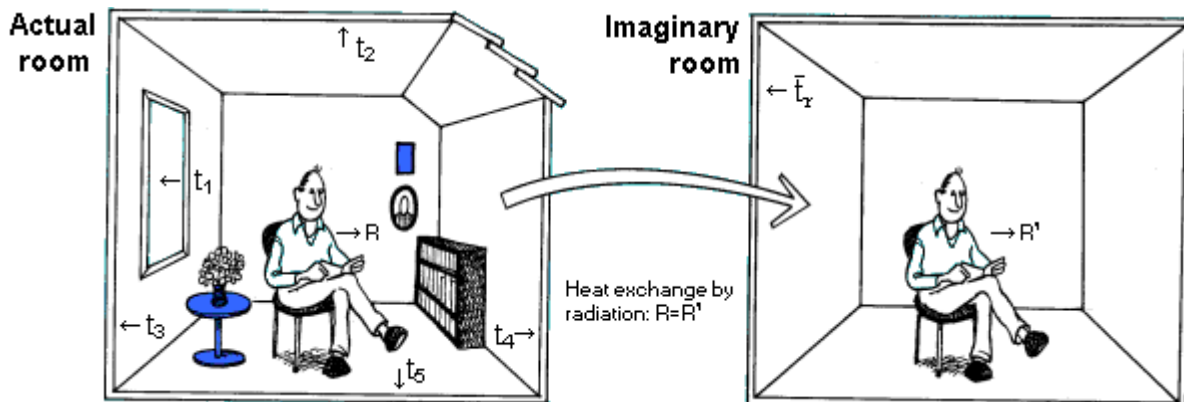

What are Operative, Equivalent and Effective Temperatures?

The way the integrated temperatures are defined and calculated can be explained using the figure. The reasoning behind all 3 temperatures mentioned is the same.

Imagine that you take a person and move him from a real room into an imaginary room. Then adjust the temperature in the imaginary room until the person experiences the same heat loss here, as in the real room. Finally, determine the Air Temperature in the imaginary room, which by definition is the integrated temperature.

Each of the integrated temperature parameters has its own specific condition which must be fulfilled in the imaginary room; these are:

t_o : v'_a and p'_a equal to the real room
 t'_a equal to \bar{t}'_r

t_{eq} : p'_a equal to the real room
 t'_a equal to \bar{t}'_r
 $v'_a = 0$

ET^* : v'_a equal to the real room
 t'_a equal to \bar{t}'_r
 p'_a level gives $RH = 50\%$

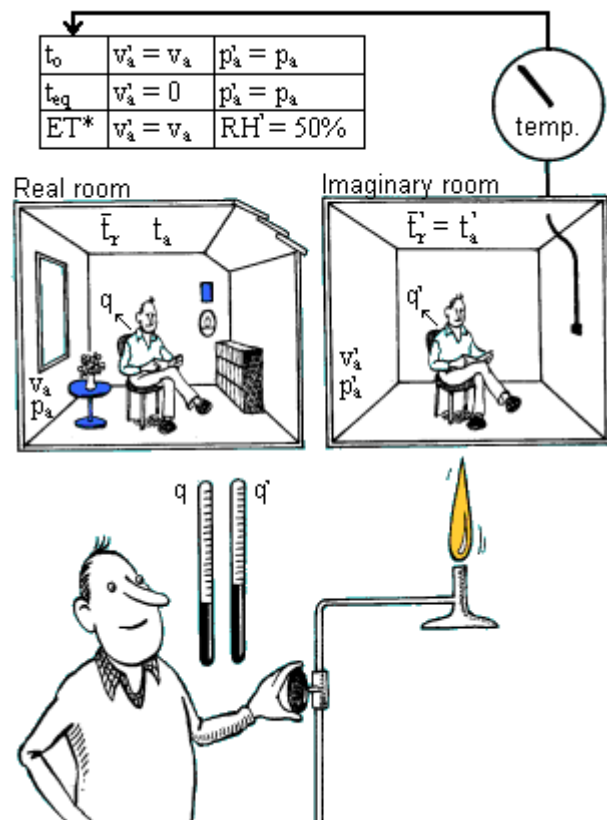

The ET^* and t_{eq} values are dependent on the persons level of activity and clothing, whereas the value t_o is normally independent of these parameters. The equation system for calculating t_o and t_{eq} is listed in Appendix A. The Operative Temperature can also be calculated using a simplified equation. For this see Appendix F. Equations for calculation of ET^* can be found in the ASHRAE handbook //.

Operative and Equivalent Temperature can be measured directly

It can be shown that the Operative Temperature at a given point for most applications will equal the temperature an unheated mannequin dummy adjusts itself to. An Operative Temperature transducer must therefore have heat exchange properties similar to those of an unheated mannequin dummy. Or, to be more precise, the transducer and the mannequin must have:

- The same convection to radiation heat loss ratio.
- The same angle factor to their surroundings.
- The same absorption factor (emissivity) for long and short wave radiation.

A light grey ellipsoid shape, 160 mm long and with a diameter of 54 mm, satisfies the specifications required for an Operative Temperature transducer. Equip this with a sensor to measure the average surface temperature and we now have an operative temperature transducer.

As a person's angle factor to their surroundings changes as they change position, the transducer must also be able to assume different positions in order for it to measure in different workplaces.

By heating the Operative Transducer to the same temperature as the surface temperature of a person's clothing, the Dry Heat Loss (H) from the body can be obtained directly. H is simply determined by the amount of energy required to sustain the surface temperature of the transducer.

If H is known, the Equivalent Temperature t_{eq} can be calculated and vice versa. The equation's used for this conversion can be seen in Appendix A.

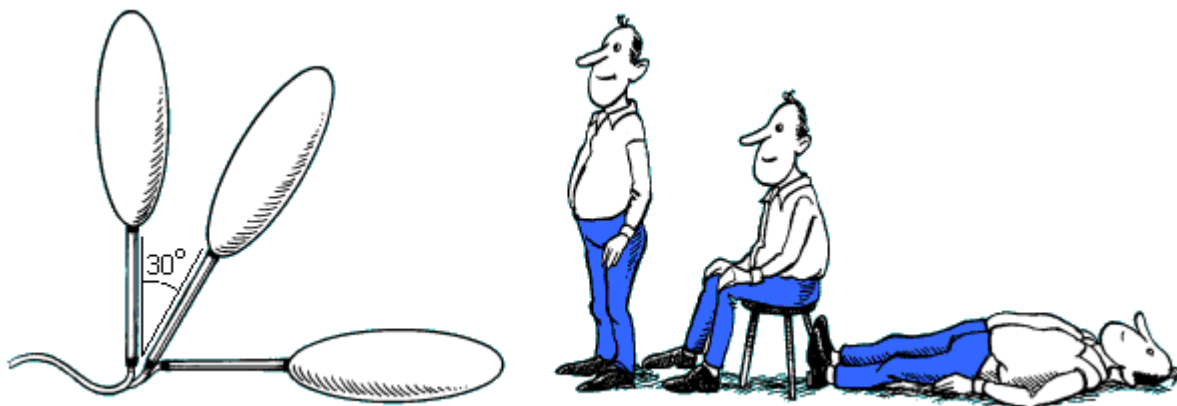

▲ How to create Thermal Comfort

When evaluating a workplace, we often talk about the Comfortable Temperature (t_{co}), which is defined as the Equivalent Temperature where a person feels thermally comfortable. We rarely talk about comfortable humidity, this is partly due to the difficulty of feeling the humidity in the air and partly due to humidity having only a slight influence on a person's heat exchange when they are close to a state of thermal comfort.

The comfort temperature in a given environment can be calculated from the comfort equation (see Appendix B). In the figure a few results from such calculations can be seen. Notice how warm it should be if someone is sitting doing work wearing a light summer dress.

If a room contains many people, wearing different types of clothing and carrying out different types of activities, it can be difficult to create an environment which provides thermal comfort for all the occupants. Something can be done by changing the factors that affect the thermal comfort locally, for example, if the equivalent temperature is lower than the comfort temperature, the mean radiant temperature can be increased by installing heated panels.

Fortunately, individuals can often optimise their own thermal comfort simply by adjusting their clothing to suit the conditions, for example, by removing a jumper, rolling up shirt sleeves or alternatively putting on a jacket.

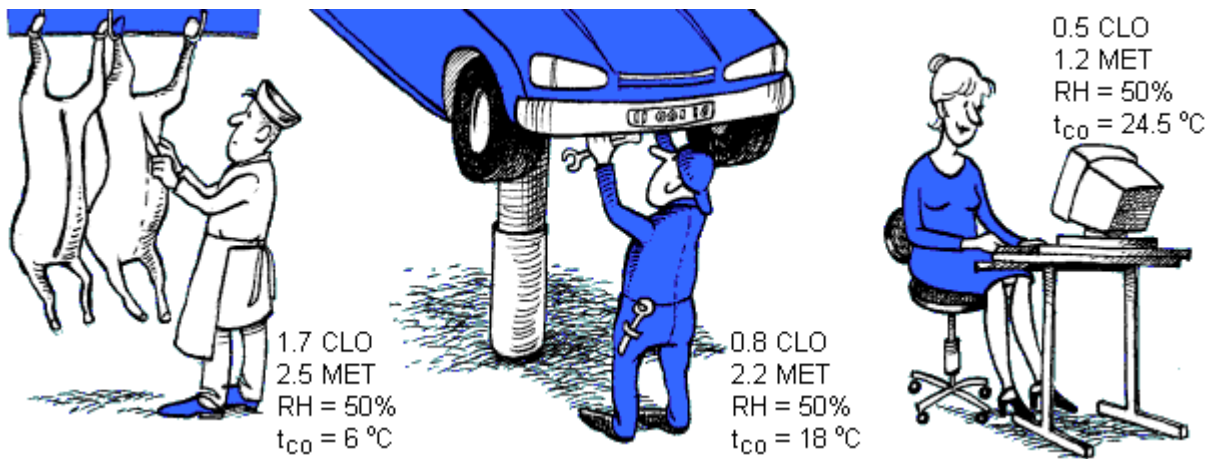

▲ The PMV and PPD scales

If the thermal comfort in a workplace is not perfect, how far from perfect is it? Or within what limits should we maintain temperature and humidity to enable reasonable thermal comfort? The answers to these questions can be obtained from the PMV-index (Predicted Mean Vote). The PMV-index predicts the mean value of the subjective ratings of a group of people in a given environment.

The PMV scale is a seven-point thermal-sensation scale ranging from -3 (cold) to +3 (hot), where 0 represents the thermally neutral sensation.

Even when the PMV-index is 0, there will still be some individuals who are dissatisfied with the temperature level, regardless of the fact that they are all dressed similarly and have the same level of activity - comfort evaluation differs a little from person to person.

To predict how many people are dissatisfied in a given thermal environment, the PPD-index (Predicted Percentage of Dissatisfied) has been introduced. In the PPD-index people who vote -3, -2, +2, +3 on the PMV scale are regarded as thermally dissatisfied.

Notice that the curve showing the relationship between PMV and PPD never gets below 5% dissatisfied.

How to calculate the PMV and PPD values can be seen in Appendix B.

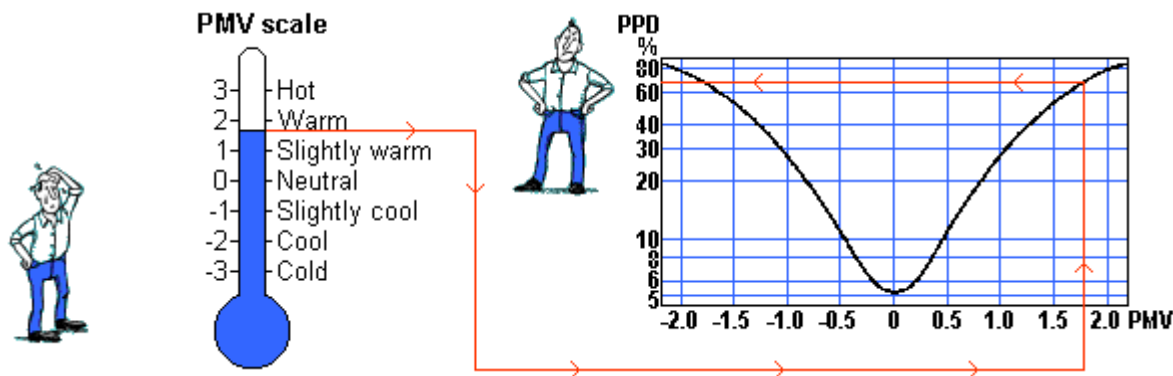

▲ Local Thermal Discomfort

Even though a person has a sensation of thermal neutrality, parts of the body may be exposed to conditions that result in thermal discomfort. This local thermal discomfort can not be

removed by raising or lowering the temperature of the enclosure. It is necessary to remove the cause of the localised over-heating or cooling.

Generally, local thermal discomfort can be grouped under one of the following four headings:

1. Local convective cooling of the body caused by draught
2. Cooling or heating of parts of the body by radiation. This is known as a radiation asymmetry problem.
3. Cold feet and a warm head at the same time, caused by large vertical air temperature differences.
4. Hot or cold feet, caused by uncomfortable floor temperature.

Remember, only when both the local and general thermal comfort parameters have been investigated, can the quality of the thermal environment be judged.

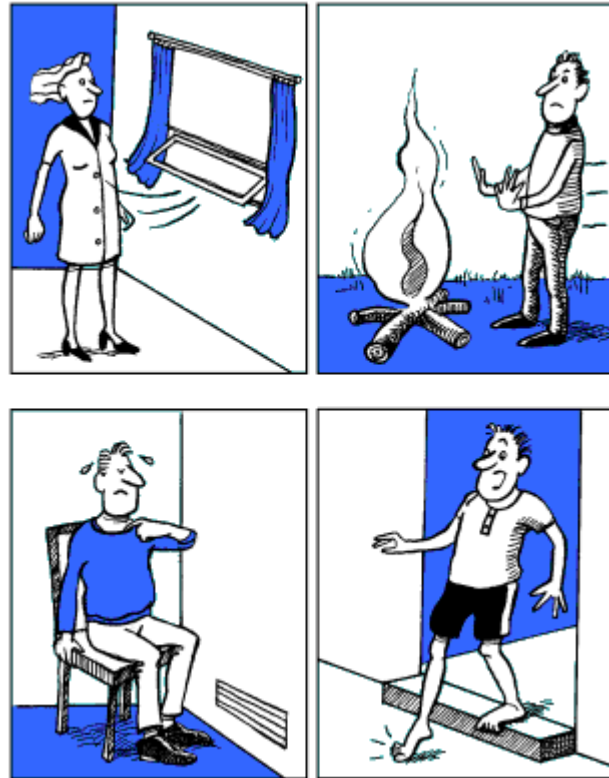

▲ Draught

Draughts are the most common complaint when talking about indoor climate in air-conditioned buildings, vehicles and aeroplanes. Man can not feel air velocity, so what people actually complain about is an unwanted local cooling of the body.

People are most sensitive to draught in the unclothed parts of the body. Therefore, draughts are usually only felt on the face, hands and lower legs.

The amount of heat loss from the skin caused by draughts is dependent on the average air velocity, as well as the turbulence in the airflow and the temperature of the air.

Due to the way the cold sensors in the skin work, the degree of discomfort felt is not only dependent on the local heat loss, the fluctuation of the skin temperature has an influence too. A high turbulent air-flow is felt to be more annoying than a low turbulent air-flow, even though they result in the same heat loss.

It is believed that it is the many step drops in the skin temperature caused by the fluctuation, that initiates excessive discomfort signals to be sent from the cold sensors.

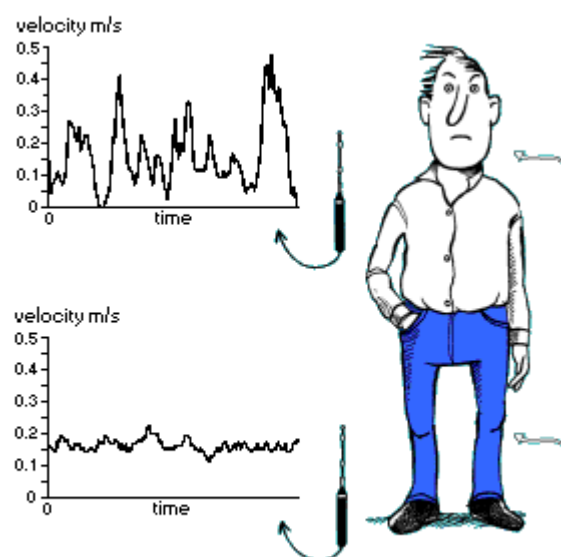

We know a bit about what types of fluctuations cause the greatest discomfort. This knowledge has been obtained by submitting groups of individuals to various air velocity frequencies. Fluctuation with a frequency of 0.5 Hz are the most uncomfortable, while frequencies above 2 Hz are not felt.

▲ Evaluating the Draught Rate

The percentage of people predicted to be dissatisfied because of a draught may be calculated by using the following equation:

$$DR = (34 - t_a) (v_a - 0.05)^{0.62} (37 \cdot SD + 3.14)$$

where:

DR Draught Rating [%]

t_a Air Temperature [°C]

v_a Local Mean Air Velocity [m/s]

SD Standard Deviation of air velocity [m/s]

To describe how fluctuating the air velocity is, we often use the term "Turbulence Intensity" which is defined as:

$$Tu = 100 \cdot \frac{SD}{v_a} \quad [\%]$$

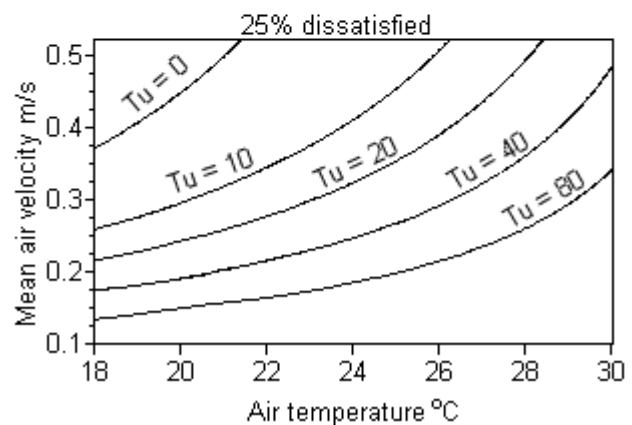
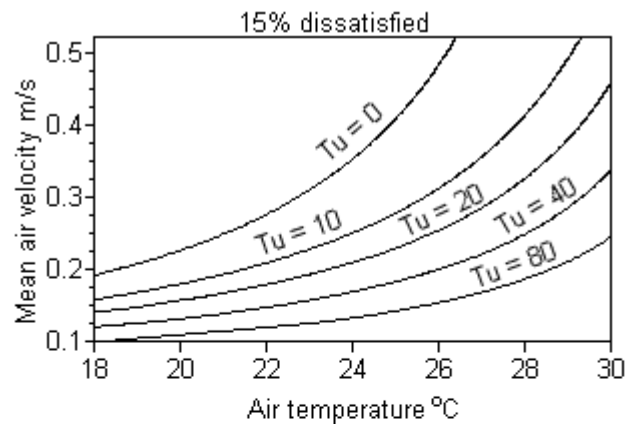

The Draught Rate equation is from the ISO 7730 standard, and is based on studies comprising 150 subjects. The equation applies to people at light mainly sedentary activity, with an overall thermal sensation close to neutral. To calculate v_a and SD a period of 3 minutes is used. For a transducer which is to be used for Draught Rating measurement, a number of severe demands are set. It must be able to measure: air velocity down to 0.05m/s, fluctuations up to 2 Hz, and must be unaffected by the direction of the air flow.

At lower velocities, the direction of the air flow in the occupied zone changes rapidly. To position an air velocity transducer in one particular direction is therefore not possible, and consequently an omnidirectional transducer must be used.

▲ Asymmetry of Thermal Radiation

If you stand in front of a blazing bonfire on a cold day, after a period of time your back will begin to feel uncomfortably cold. This discomfort can not be remedied by moving closer to the fire, resulting in an increased body temperature. This is an example of how non-uniform thermal radiation can result in the body feeling uncomfortable. To describe this non uniformity in the thermal radiation field, the parameter Radiant Temperature Asymmetry is used. This parameter is defined as the difference between the Plane Radiant Temperature of the two opposite sides of a small plane element.

Experiments exposing people to changing degrees of radiant temperature asymmetry have proved that warm ceilings and cold windows cause the greatest discomfort, while cold ceilings and warm walls cause the least discomfort. During these experiments all the other surfaces in the room and the air were kept at an equal temperature.

The parameter Radiant Temperature Asymmetry can be obtained in two ways. One, by measuring t_{pr} in two opposite directions using a transducer that integrates the incoming radiation on to a small plane element from the hemisphere about it. The other is, to measure the temperatures of all the surrounding surfaces and then calculate Radiant Temperature Asymmetry. In Appendix F the procedure to be used for such a calculation can be seen.

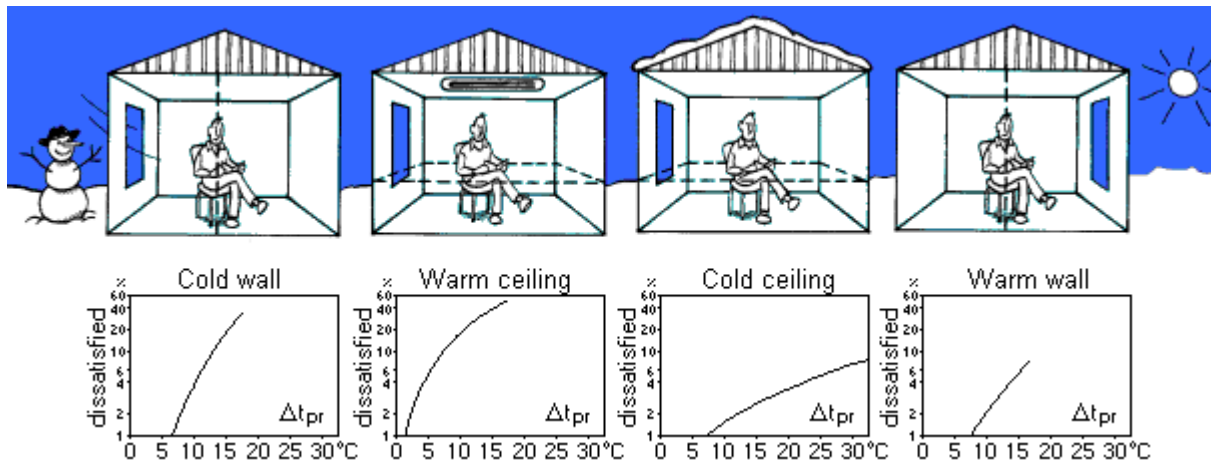

Vertical Air Temperature Difference

Generally it is unpleasant to be warm around the head whilst at the same time being cold around the feet, regardless of this being caused by radiation or convection. In the last section we looked at the acceptance limits of Radiant Temperature Asymmetry. Here we will look at what air temperature difference is acceptable between the head and feet.

Experiments were carried out with people in a state of thermal neutrality. The results, displayed in the diagram, showed that a 3°C air temperature difference between head and feet gave a 5% dissatisfaction level. The 3°C have been chosen as the ISO 7730 acceptance level for a sitting person at sedentary activity.

When measuring air temperature differences it is important to use a transducer which is shielded against thermal radiation. This ensures that the air temperature is measured and not an undefined combination of air and radiant temperature.

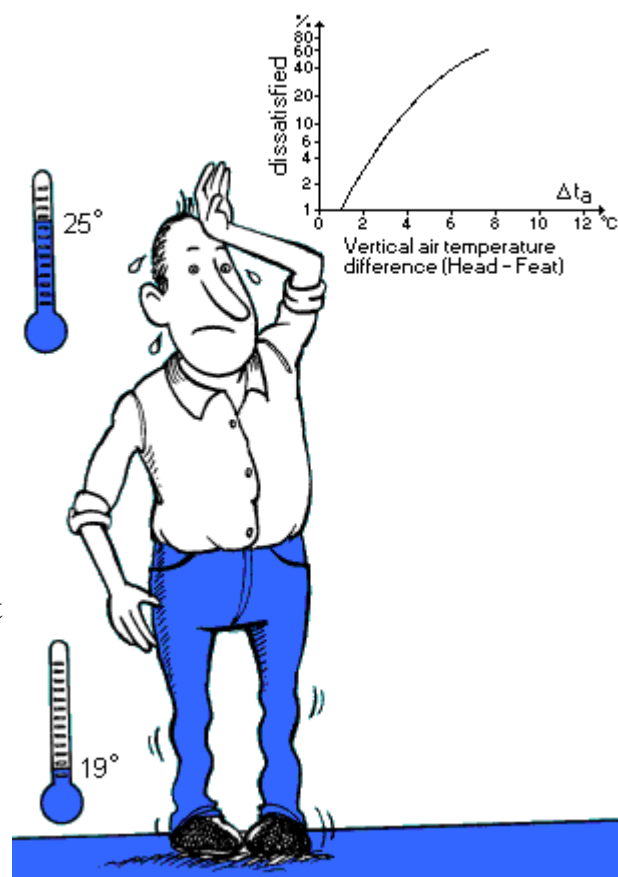

The Vertical Air Temperature difference is expressed as the difference between the Air Temperature at ankle level and the Air Temperature at neck level.

▲ Floor Temperature

Due to the direct contact between feet and floor, local discomfort of the feet can often be caused by too high or too low a floor temperature.

To talk about thermal discomfort caused by the floor temperature is incorrect as it is the heat loss from the feet that causes the discomfort. The heat loss depends on parameters other than the floor temperature, such as the conductivity and the heat capacity of the material the floor is made from and the type of covering worn on the feet.

It is the difference in conductivity and heat capacity that makes cork floors feel warm to the touch whilst marble floors feel cold.

If people wear "normal indoor footwear" the floor material is less significant. Therefore, it has been possible to set some comfort levels for this "normal" situation.

The ISO 7730 standard sets comfort levels at sedentary activity to 10% dissatisfied. This leads to acceptable Floor Temperatures ranging from 19°C to 29°C.

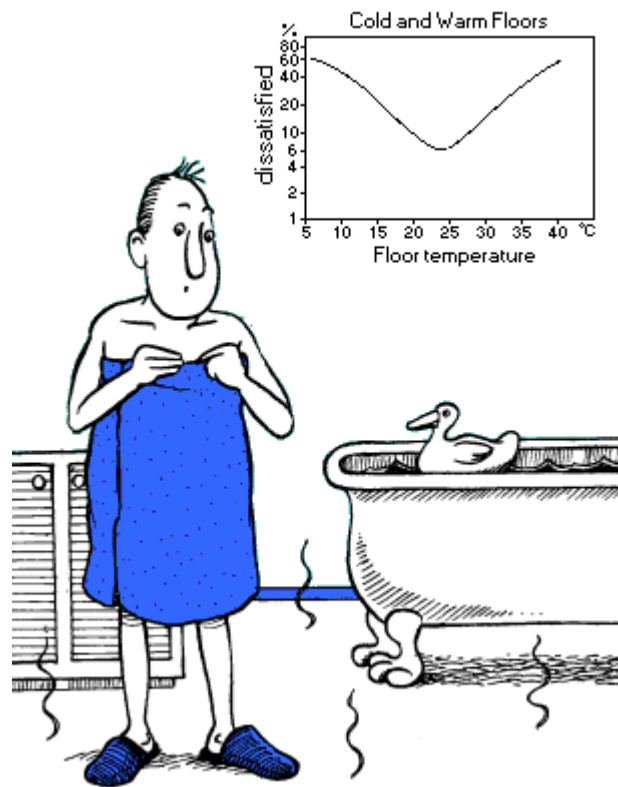

Quite different recommendations are valid for floors occupied by people with bare feet. In a bathroom the optimal temperature is 29°C for a marble floor and 26°C for hard linoleum on wood.

▲ How to perform a measurement in a workplace

Where should the transducer be placed when measuring at a workplace? The positions normally used for sitting and standing persons are shown in the figure.

In general, the transducers should be placed at the person's centre of gravity. Exceptions to this rule are when Vertical Air Temperature Differences and draughts are being measured. These measurements must be made at both ankle and neck levels.

Dependent on the method chosen to measure the Dry Heat Loss H one, two or three transducers are needed. The options are:

- A Dry Heat Loss transducer
- An Operative Temperature and an Air Velocity transducer.
- A Radiant Temperature, an Air Temperature and an Air Velocity transducer.

For evaluation of thermal comfort at a workplace for sedentary activity, ISO 7730 suggests the following requirements:

- $-0.5 < PMV < +0.5$
- $DR < 15\%$ at neck and ankle.
- Vertical Air Temperature Differences from ankle to head should be less than 3°C .
- Radiant Temperature Asymmetry from cold windows should be less than 10°C .
- Radiant Temperature Asymmetry from warm ceilings should be less than 5°C .
- Surface Temperature of floors should be between 19°C and 29°C .
- Relative Humidity should be between 30% and 70%.

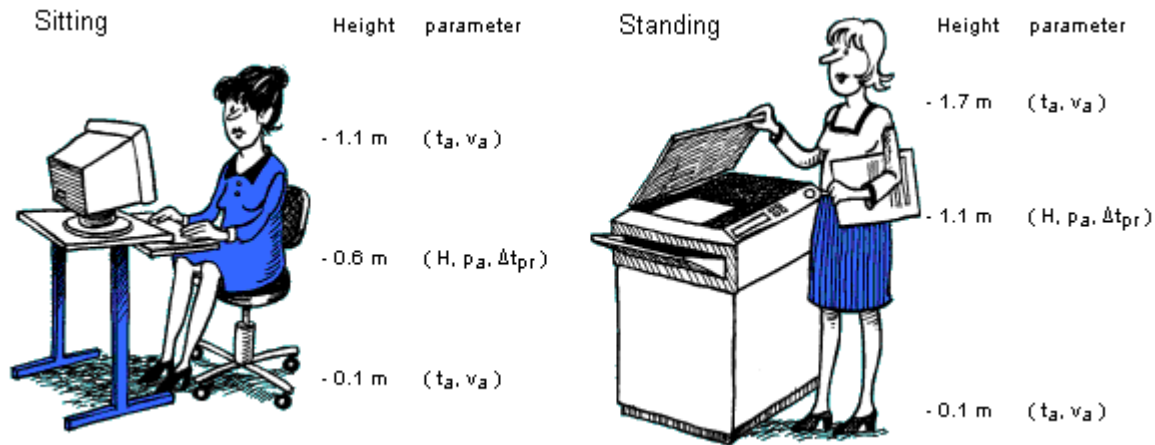

How to evaluate the Thermal Quality of a room

In rooms with several workplaces under a common climatic control system, one has to evaluate comfort in a number of steps.

1. Uniformity of the thermal climate within the working area. This can be evaluated by measuring PMV values at a few workplaces simultaneously. Among the places chosen should be the one expected to be the coldest, the one expected to be the warmest and one in the centre of the room.

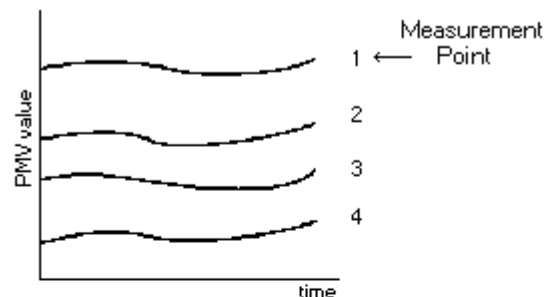

2. The ability of the climatic control system to maintain a stable thermal climate. By logging the time history of the PMV value, variations in the thermal climate are easily unveiled.

3. Risk of local thermal discomfort in the working area. This can be measured one workplace at a time as described in the previous chapters.

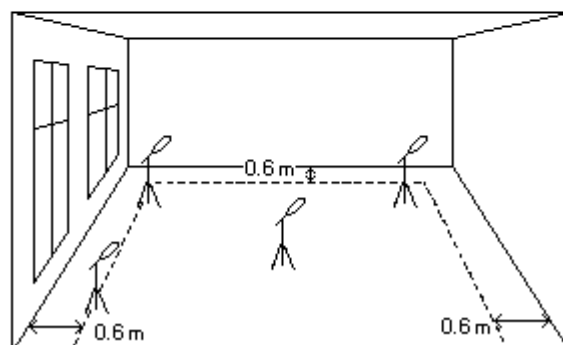

In rooms where the workplaces are not easily identified the measurement point should be placed at least 0.6 m away from walls or fixed heating or air-conditioning equipment.

The PMV calculation must be done with clothing and activity values which are reasonable for the room in question.

▲ Further Reading

- /1/ P.O. Fanger, Thermal Comfort, McGraw-Hill Book Company 1972.
- /2/ ISO 7730, Moderate Thermal Environments - Determination of the PMV and PPD indices and specification of the conditions for thermal comfort, 1995.1)
- /3/ ISO 7726, Thermal Environment - Instruments and method for measuring physical quantities, 1985.1)
- /4/ ISO/DIS 13731, Ergonomics of the Thermal Environment - Definition and units, February 1996.1)
- /5/ ISO 8996, Ergonomics - Determination of Metabolic Heat Production, 1990.1)
- /6/ ISO 9920, Ergonomics of the Thermal Environment - Estimation of the thermal insulation and evaporative resistance of a clothing ensemble, 1995.1)
- /7/ ASHRAE handbook Fundamentals, American Society of Heating and Air Conditioning Engineers, Atlanta 1993.
- /8/ B.W. Olesen, Thermal Comfort Requirement for Floors Occupied by People with Bare Feet, ASHRAE Trans., Vol. 83 Part 2, 1977.
- /9/ E.A. McCullough, B.W. Olesen and S. Hong, Thermal Insulation Provided by Chairs, ASHRAE Transactions 1994.
- /10/ P.O. Fanger, A.K. Melikov, H. Hanzawa and J. Ring. Air Turbulence and Sensation of Draught. Energy and Building 12(1988) 21-39, Elsevier Amsterdam 1988.
- /11/ D.A. McIntyre, Indoor Climate, Applied Science publishers LTD, London 1980
- /12/ T.H. Benzinger, The Physiological Basis for Thermal Comfort, Proceedings of the First International Indoor Climate Symposium, Danish Building Research Institute, Copenhagen 1979.
- 1) International Organization for Standardization, Geneva.

▲ Appendix A: Dry Heat Loss calculations

The Dry Heat loss:

$$H = \varepsilon \sigma \frac{A_r}{A_{Du}} \cdot f_{cl} \left[(t_{cl} + 273)^4 - (\bar{t}_r + 273)^4 \right] + f_{cl} \cdot h_c \cdot (t_{cl} - t_a) \quad [1a]$$

or written with Operative Temperature:

$$H = \varepsilon \sigma \frac{A_r}{A_{Du}} \cdot f_{cl} \left[(t_{cl} + 273)^4 - (t_o + 273)^4 \right] + f_{cl} \cdot h_c \cdot (t_{cl} - t_o) \quad [1b]$$

or written with Equivalent Temperature:

$$H = \varepsilon \sigma \frac{A_r}{A_{Du}} \cdot f_{cl} \left[(t_e + 273)^4 - (t_o + 273)^4 \right] + f_{cl} \cdot h_c \cdot (t_e - t_o) \quad [1c]$$

another equation for H is:

$$H = K_{cl} = \frac{\bar{t}_{sk} - t_{cl}}{I_{cl}} \quad [2]$$

when equations 1 and 2 are combined, t_{cl} can be derived:

$$t_{cl} = t_{sk} - I_{cl} \cdot k_1 \cdot f_{cl} \left[(t_{cl} + 273)^4 - (\bar{t}_r + 273)^4 \right] - I_{cl} \cdot f_{cl} \cdot h_c \cdot (t_{cl} - t_a) \quad [3a]$$

or written with Operative Temperature:

$$t_{cl} = t_{sk} - I_{cl} \cdot k_1 \cdot f_{cl} \left[(t_{cl} + 273)^4 - (t_o + 273)^4 \right] - I_{cl} \cdot f_{cl} \cdot h_c \cdot (t_{cl} - t_o) \quad [3b]$$

or written with Equivalent Temperature:

$$t_{cl} = t_{sk} - I_{cl} \cdot k_1 \cdot f_{cl} \left[(t_{cl} + 273)^4 - (t_{eq} + 273)^4 \right] - I_{cl} \cdot f_{cl} \cdot h_{c,eq} \cdot (t_{cl} - t_{eq}) \quad [3c]$$

where:

$$k_1 = \varepsilon \cdot \sigma \cdot \frac{A_r}{A_{Du}} = 39.6 \cdot 10^{-9} \quad [4]$$

$$h_c = \begin{cases} 2.38 \cdot (t_{cl} - t_a)^{0.25} & \text{for } 2.38 \cdot (t_{cl} - t_a)^{0.25} > 12.1 \cdot \sqrt{v_{ar}} \\ 12.1 \cdot \sqrt{v_{ar}} & \text{for } 2.38 \cdot (t_{cl} - t_a)^{0.25} \leq 12.1 \cdot \sqrt{v_{ar}} \end{cases} \quad [5a]$$

$$h_c = \begin{cases} 2.38 \cdot (t_{cl} - t_o)^{0.25} & \text{for } 2.38 \cdot (t_{cl} - t_o)^{0.25} > 12.1 \cdot \sqrt{v_{ar}} \\ 12.1 \cdot \sqrt{v_{ar}} & \text{for } 2.38 \cdot (t_{cl} - t_o)^{0.25} \leq 12.1 \cdot \sqrt{v_{ar}} \end{cases} \quad [5b]$$

$$h_{c,eq} = 2.38 \cdot (t_{cl} - t_{eq})^{0.25} \quad [5c]$$

$$f_{cl} = \begin{cases} 1.00 + 1.29 \cdot I_{cl} & \text{for } I_{cl} < 0.078 \text{ m}^2\text{°C/W} \\ 1.05 + 0.645 \cdot I_{cl} & \text{for } I_{cl} \geq 0.078 \text{ m}^2\text{°C/W} \end{cases} \quad [6]$$

$$t_{sk} = 35.7 - 0.028 \cdot (M - W) \quad [7]$$

Calculation of t_{cl} is an iterative process, whereas, the calculation of H is more straightforward.

The equation is in accordance with ISO 7730 /ref. 2/.

▲ Appendix B: Heat Balance, Comfort and PMV equations

Heat Balance equation for the body:

$$M - W = H + E + C_{res} + E_{res} \quad [8]$$

Comfort equation:

$$M - W = H + E_c + C_{res} + E_{res} \quad [9]$$

PMV equation:

$$PMV = (0.303 \cdot e^{-0.036 \cdot M} + 0.028) \cdot [(M - W) - H - E_c - C_{res} - E_{res}] \quad [10]$$

PPD equation:

$$PPD = 100 - 95 \cdot e^{-(0.03353 \cdot PMV^4 + 0.2179 \cdot PMV^2)} \quad [11]$$

Procedure for the calculation of parameters in the above equations:

$$E = 3.05 \cdot 10^{-3} \cdot (256 \cdot \bar{t}_{sk} - 3373 - p_a) + E_{sw} \quad [12]$$

$$E_c = 3.05 \cdot 10^{-3} \cdot [5733 - 6.99 \cdot (M - W) - p_a] + 0.42 \cdot (M - W - 58.15) \quad [13]$$

$$C_{res} = 0.0014 \cdot M \cdot (34 - t_a) \quad [14]$$

$$E_{res} = 1.72 \cdot 10^{-5} \cdot M \cdot (5867 - p_a) \quad [15]$$

H is either measured directly using a dry heat loss transducer or calculated from the equation in Appendix A.

E_{sw} and t_{sk} in the heat balance equation have to be measured.

The external work W can, in most cases, be set equal to zero.

All equations are in accordance with Fanger /ref. 1/ and ISO 7730 /ref. 2/.

In the comfort and PMV equations the physiological response of the thermoregulatory system has been related statistically to thermal sensation votes collected from more than 1300 subjects.

Appendix C: Met value table

Activity	Metabolic rates [M]	W/m2	Met
Reclining		46	0.8
Seated relaxed		58	1.0

Clock and watch repairer	65	1.1
Standing relaxed	70	1.2
Sedentary activity (office, dwelling, school, laboratory)	70	1.2
Car driving	80	1.4
Graphic profession - Book Binder	85	1.5
Standing, light activity (shopping, laboratory, light industry)	93	1.6
Teacher	95	1.6
Domestic work -shaving, washing and dressing	100	1.7
Walking on the level, 2 km/h	110	1.9
Standing, medium activity (shop assistant, domestic work)	116	2.0
Building industry -Brick laying (Block of 15.3 kg)	125	2.2
Washing dishes standing	145	2,5
Domestic work -raking leaves on the lawn	170	2.9
Domestic work -washing by hand and ironing (120-220 W/m ²)	170	2.9
Iron and steel -ramming the mould with a pneumatic hammer	175	3.0
Building industry -forming the mould	180	3.1
Walking on the level, 5 km/h	200	3.4
Forestry -cutting across the grain with a one-man power saw	205	3.5
Agriculture -Ploughing with a team of horses	235	4.0
Building industry -loading a wheelbarrow with stones and mortar	275	4.7
Sports -Ice skating, 18 km/h	360	6.2
Agriculture -digging with a spade (24 lifts/min.)	380	6.5
Sports -Skiing on level, good snow, 9 km/h	405	7.0
Forestry -working with an axe (weight 2 kg. 33 blows/min.)	500	8.6
Sports -Running, 15 km/h	550	9.5



1.1 Met



2.5 Met













6.5 Met

Appendix D: Clo values table

Garment description	Iclu	Clo	m ² °C/W
Underwear, pants			
Pantyhose		0.02	0.003
Panties		0.03	0.005
Briefs		0.04	0.006
Pants 1/2 long legs, wool		0.06	0.009
Pants long legs		0.1	0.016
Underwear, shirts			
Bra		0.01	0.002
Shirt sleeveless		0.06	0.009
T-shirt		0.09	0.014
Shirt with long sleeves		0.12	0.019
Half-slip, nylon		0.14	0.022
Shirts			
Tube top		0.06	0.009
Short sleeve		0.09	0.029
Light weight blouse, long sleeves		0.15	0.023
Light weight, long sleeves		0.20	0.031
Normal, long sleeves		0.25	0.039
Flannel shirt, long sleeves		0.3	0.047

	Long sleeves, turtleneck blouse	0.34	0.053
Trousers	Shorts	0.06	0.009
	Walking shorts	0.11	0.017
	Light-weight trousers	0.20	0.031
	Normal trousers	0.25	0.039
	Flannel trousers	0.28	0.043
	Overalls	0.28	0.043
Coveralls	Daily wear, belted	0.49	0.076
	Work	0.50	0.078
Highly-insulating coveralls	Multi-component, filling	1.03	0.160
	Fibre-pelt	1.13	0.175
Sweaters	Sleeveless vest	0.12	0.019
	Thin sweater	0.2	0.031
	Long sleeves, turtleneck (thin)	0.26	0.040
	Sweater 0.28 0.043 Thick sweater	0.35	0.054
	Long sleeves, turtleneck (thick)	0.37	0.057
Jacket	Vest	0.13	0.020
	Light summer jacket	0.25	0.039
	Jacket	0.35	0.054
	Smock	0.3	0.047
Coats and overjackets and overtrousers	Coat	0.6	0.093
	Down jacket	0.55	0.085
	Parka	0.7	0.109
	Overalls multi-component	0.52	0.081
Sundries	Socks	0.02	0.003
	Thick, ankle socks	0.05	0.008
	Thick, long socks	0.1	0.016
	Slippers, quilted fleece	0.03	0.005
	Shoes (thin soled)	0.02	0.003
	Shoes (thick soled)	0.04	0.006
	Boots 0.1 0.016 Gloves	0.05	0.008
Skirts, dresses	Light skirt, 15 cm. above knee	0.10	0.016
	Light skirt, 15 cm. below knee	0.18	0.028
	Heavy skirt, knee-length	0.25	0.039
	Light dress, sleeveless	0.25	0.039
	Winter dress, long sleeves	0.4	0.062
Sleepwear	Long sleeve, long gown	0.3	0.047
	Thin strap, short gown	0.15	0.023
	Hospital gown	0.31	0.048
	Long sleeve, long pyjamas	0.50	0.078
	Body sleep with feet	0.72	0.112
	Undershorts	0.1	0.016
Robes	Long sleeve, wrap, long	0.53	0.082
	Long sleeve, wrap, short	0.41	0.064
Chairs	Wooden or metal	0.00	0.000
	Fabric-covered, cushioned, swivel	0.10	0.016
	Armchair	0.20	0.032

Insulation for the entire clothing: $I_{cl} = \sum I_{clu}$

	0.19		0.28
+			0.25
	0.04		0.04
+			0.25
	0.11		0.05
+			0.04
	0.02		
+			
	<u>0.02</u>		
	0.38		0.91

Appendix E: Calculation of Mean Radiant Temperature

Equation for calculating the Mean Radiant Temperature from the Air-and Globe Temperature:

$$\bar{t}_r = \sqrt[4]{(t_g + 273)^4 + \frac{h_{cg}}{h_r} \cdot (t_g - t_a) - 273}$$

The following equation can be used for calculating the heat transfer coefficient:

$$h_r = \epsilon \cdot \sigma = 0.95 \cdot 5.67 \cdot 10^{-8} = 5.38 \cdot 10^{-8}$$

For a globe (from /ref. 3/):

$$h_{cg} = \max_of \begin{cases} 6.3 \cdot \frac{(v_a)^{0.6}}{D^{0.4}} & \text{Forced convection} \\ 1.4 \cdot \left(\frac{|t_g - t_a|}{D} \right)^{0.25} & \text{Free convection} \end{cases}$$

For an Operative Temperature Transducer¹:

$$h_{cg} = \max_of \begin{cases} 18 \cdot (v_a)^{0.55} & \text{Forced convection} \\ 3 \cdot \left(|t_g - t_a| \right)^{0.25} & \text{Free convection} \end{cases}$$

- 1) An ellipsoid shaped sensor that is 160 mm long and 54 mm in diameter

Mean Radiant Temperature estimated from a measured value of Plane Radiant Temperature

The Mean Radiant Temperature can be calculated with a good degree of accuracy from six measured values of the Plane Radiant Temperature.

For a sitting person the equation is:

$$\bar{t}_r = \frac{0.18 \cdot [t_{pr}(up) + t_{pr}(down)] + 0.22 \cdot [t_{pr}(right) + t_{pr}(left)] + 0.30 \cdot [t_{pr}(front) + t_{pr}(back)]}{2 \cdot (0.18 + 0.22 + 0.30)}$$

and for a standing person:

$$\bar{t}_r = \frac{0.08 \cdot [t_{pr}(up) + t_{pr}(down)] + 0.23 \cdot [t_{pr}(right) + t_{pr}(left)] + 0.35 \cdot [t_{pr}(front) + t_{pr}(back)]}{2 \cdot (0.08 + 0.23 + 0.35)}$$

Appendix F: Calculation of Plane Radiant and Operative Temperature

The following equation may be used to calculate the Plane Radiant Temperature:

$$t_{pr} = \sqrt[4]{\sum_n F_{pl-i} (t_i + 273)^4 - 273}$$

t_i is surface temperature of surface no. i [°C]

F_{pl-i} is angle factor between a small plane and surface

$$\sum_i F_{pl-i} = 1$$

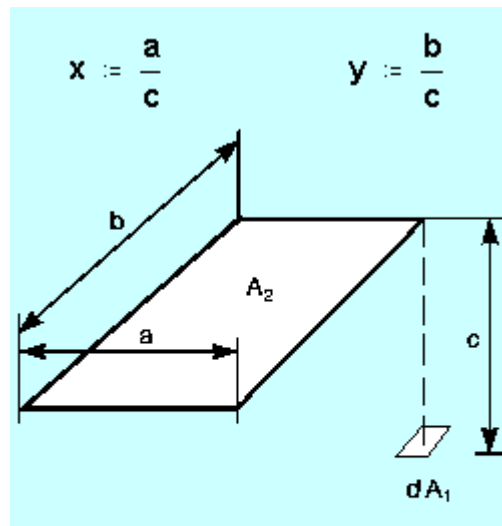

$$F_{pl-2} = \frac{1}{2 \cdot \pi} \left(\frac{x}{\sqrt{1+x^2}} \cdot \tan^{-1} \left(\frac{y}{\sqrt{1+x^2}} \right) + \frac{y}{\sqrt{1+y^2}} \cdot \tan^{-1} \left(\frac{x}{\sqrt{1+y^2}} \right) \right)$$

$$F_{pl-3} = \frac{1}{2 \cdot \pi} \left(\tan^{-1} \left(\frac{1}{y} \right) - \frac{y}{\sqrt{x^2 + y^2}} \cdot \tan^{-1} \left(\frac{1}{\sqrt{x^2 + y^2}} \right) \right)$$

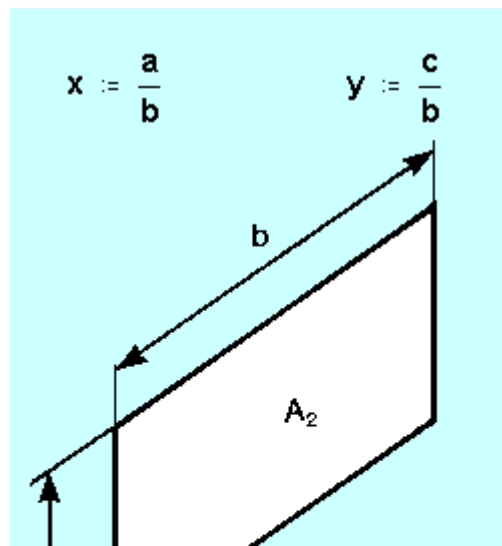

Calculation of Operative Temperature

The following simplified equation gives reasonable accuracy:

$$t_o = A \cdot t_a + (1 - A) \cdot \bar{t}_r$$

v_{ar}	< 0.2	0.2 - 0.6	0.6 - 1.0
A	0.5	0.6	0.7

The equation is from /ref. 2/

▲ Nomenclature

a	Width of a rectangular surface.	[m]
A_{Du}	DuBois body surface area. The total surface area of a naked person as estimated by the DuBois formula.	[m ²]
A_i	Area of plane surface.	[m ²]
A_r	Effective radiant area of a body. Surface that exchanges radiant energy with the environment through a solid angle of 4 ^l . This is smaller than the actual surface area of the body because the body is not a convex surface.	[m ²]
b	Length of a rectangular surface.	[m]
c	Distance between the two surfaces.	[m]
C_{res}	Respiratory convective heat exchange.	[W/m ²]
D	Diameter of globe transducer.	[m]
DR	Draught Rate. The percentage of people dissatisfied due to draught.	[%]
E	Evaporative heat exchange at the skin.	[W/m ²]
E_c	Evaporative heat exchange at the skin, when the person experiences a sensation of thermal neutrality.	[W/m ²]
E_{res}	Respiratory evaporative heat exchange.	[W/m ²]
E_{sw}	Evaporative heat loss from evaporation of sweat.	[W/m ²]
ET*	Effective temperature (new effective temperature)	[°C]
f_{cl}	Clothing area factor. The ratio of the surface area of the clothed body to the surface area of the naked body.	
F_{p-i}	Angle factor between the person and surface i . Defined as the fraction of diffuse radiant energy leaving the body surface which falls directly upon surface i	
F_{pl-i}	Angle factor between a small plane and surface i . Defined as the fraction of diffuse radiant energy leaving the small plane surface which falls directly upon surface i	
h_c	Convective heat transfer coefficient.	[W/m ² /°C]
$h_{c,eq}$	Convective heat transfer coefficient when air velocity in enclosure is zero.	[W/m ² /°C]
h_{cg}	Convective heat transfer coefficient for a globe (ellipsoid).	[W/m ² /°C]
h_r	Radiative heat transfer coefficient.	[W/m ² /°C]
H	Dry Heat Loss. Heat loss from the body surface through convection, radiation and conduction.	[W/m ²]
I_{cl}	Clothing insulation. It is an average including uncovered parts of the body.	[m ² °C/W]
I_{clu}	Garment insulation. Expressed as the overall increase in insulation attributable to the garment.	[m ² °C/W]
K_{cl}	Conductive heat flow through clothing.	[W/m ²]
M	Metabolic rate. The rate of transformation of chemical energy into heat and mechanical work by aerobic and anaerobic activities within the body.	[W/m ²]

p_a	Humidity. Partial water vapour pressure in the air.	[Pa]
p'_a	Humidity in the imaginary room.	[Pa]
PMV	Predicted Mean Vote. The predicted mean vote of a group of people on the 7-point thermal sensation scale.	
PPD	Predicted Percentage of Dissatisfied. The predicted percentage of a group of people who are feeling too cold or too hot.	[%]
q	Heat exchange between body and surroundings.	[W/m ²]
q'	Heat exchange between body and surroundings in the imaginary room.	[W/m ²]
R	Radiative heat exchange.	[W/m ²]
R'	Radiative heat exchange in the imaginary room.	[W/m ²]
RH	Relative Humidity	[%]
SD	Standard Deviation of air velocity	[m/s]
t_a	Air Temperature	[°C]
t'_a	Air Temperature in imaginary room	[°C]
t_{co}	Comfort Temperature. The Equivalent Temperature at which a person experiences a sensation of thermal neutrality.	[°C]
t_{cl}	Clothing surface temperature.	[°C]
t_{eq}	Equivalent Temperature.	[°C]
t_g	Globe Temperature.	[°C]
t_i	Temperature of surface no. i.	[°C]
t_o	Operative Temperature.	[°C]
\bar{t}_x	Mean Radiant Temperature	[°C]
\bar{t}_r	Mean Radiant Temperature in the imaginary room	[°C]
t_{pr}	Plane Radiant Temperature.	[°C]
Δt_{pr}	Radiant Temperature Asymmetry	[°C]
\bar{t}_{sk}	Mean skin temperature	[°C]
Tu	Turbulence Intensity.	[%]
v_a	Local Mean Air Velocity	[m/s]
v'_a	Local Mean Air Velocity in the imaginary room	[m/s]
v_{ar}	Relative Mean Air Velocity. The air velocity relative to the occupant, including body movements.	[m/s]
W	Effective mechanical power.	[W/m ²]
ϵ	Emission coefficient of the body surface expressed as a ratio of the black body emissivity.	
σ	Stefan-Boltzmann constant ($5.67 * 10^{-8}$)	[W/m ² /°C ⁴]

It is our hope that this booklet has been a useful introduction to thermal comfort and the methods used to evaluate it. If you have any questions about instrumentation or special applications, please contact your local representative or write directly to:

Innova AirTech Instruments

[INNOVA](#) | [Products](#) | [Solutions](#) | [News](#) | [Contacts](#) | [Links](#) | [Books](#)



This page last updated on Mar 18, 1997.

Copyright © 1997 Innova AirTech Instruments A/S. All rights reserved.